

## DM74ALS874B Dual 4-Bit D-Type Edge-Triggered Flip-Flop with 3-STATE Outputs

### General Description

This dual 4-bit register features totem-pole 3-STATE outputs designed specifically for driving highly-capacitive or relatively low-impedance loads. The high-impedance state and increased high-logic-level drive provide this register with the capability of being connected directly to and driving the bus lines in a bus-organized system without need for interface or pull-up components. It is particularly attractive for implementing buffer registers, I/O ports, bidirectional bus drivers, and working registers.

The eight flip-flops of the 'ALS874B are edge-triggered D-type flip-flops. On the positive transition of the clock, the Q outputs will be set to the logic states that were set up at the D inputs.

A buffered output control input can be used to place the eight outputs in either a normal logic state (high or low logic levels)

or a high-impedance state. In the high-impedance state the outputs neither load nor drive the bus lines significantly.

The output control does not affect the internal operation of the flip-flops. That is, the old data can be retained or new data can be entered even while the outputs are off.

### Features

- Switching specifications at 50 pF
- Switching specifications guaranteed over full temperature and  $V_{CC}$  range
- Advanced oxide-isolated, ion-implanted Schottky TTL process
- 3-STATE buffer-type outputs drive bus lines directly
- Space saving 300 mil wide package
- Asynchronous clear

### Connection Diagram

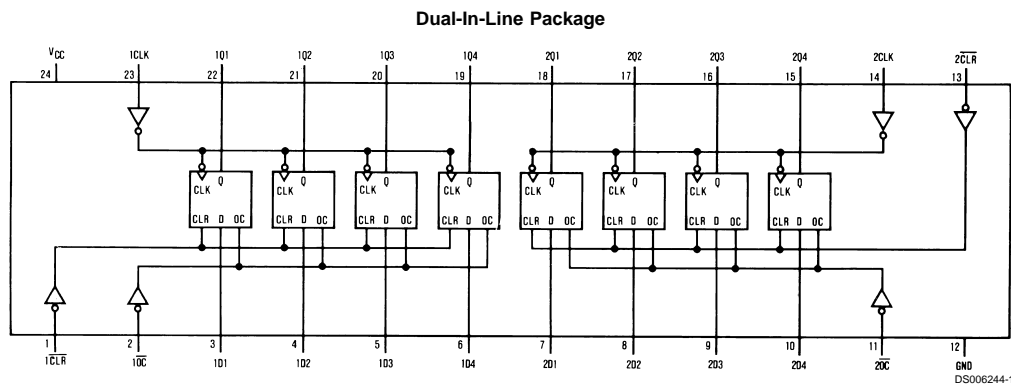

Order Number DM74ALS874BWM or DM74ALS874BNT  
See Package Number M24B or N24C

**DM74ALS874B Dual 4-Bit D-Type Edge-Triggered Flip-Flop with 3-STATE Outputs**

## Absolute Maximum Ratings (Note 2)

Supply Voltage	7V	DM74ALS	0°C to +70°C
Input Voltage	7V	Storage Temperature Range	-65°C to +150°C
Voltage Applied to Disabled Output	5.5V	Typical $\theta_{JA}$	
Operating Free Air Temperature Range		N Package	51.0°C/W
		M Package	86.5°C/W

## Recommended Operating Conditions

Symbol	Parameter	DM74ALS874B			Units
		Min	Nom	Max	
$V_{CC}$	Supply Voltage	4.5	5	5.5	V
$V_{IH}$	High Level Input Voltage	2			V
$V_{IL}$	Low Level Input Voltage			0.8	V
$I_{OH}$	High Level Output Current			-2.6	mA
$I_{OL}$	Low Level Output Current			24	mA
$f_{CLK}$	Clock Frequency	0		30	MHz
$t_{WCLK}$	Width of Clock Pulse	High	16.5		ns
		Low	16.5		ns
$t_{WCLR}$	Width of Clear Pulse	Low	10		ns
$t_{SU}$	Data Setup Time (Note 3)		15 $\uparrow$		ns
$t_H$	Data Hold Time (Note 3)		0 $\uparrow$		ns
$t_{SU}$	Clear Inactive		12		ns
$T_A$	Free Air Operating Temperature	0		70	°C

**Note 1:** This product meets application requirements of 500 temperature cycles from -65°C to +150°C

**Note 2:** The "Absolute Maximum Ratings" are those values beyond which the safety of the device cannot be guaranteed. The device should not be operated at these limits. The parametric values defined in the "Electrical Characteristics" table are not guaranteed at the absolute maximum ratings. The "Recommended Operating Conditions" table will define the conditions for actual device operation.

**Note 3:** The ( $\uparrow$ ) arrow indicates the positive edge of the Clock is used for reference.

## Electrical Characteristics

over recommended operating free air temperature range. All typical values are measured at  $V_{CC} = 5V$ ,  $T_A = 25^\circ C$ .

Symbol	Parameter	Conditions	Min	Typ	Max	Units	
$V_{IK}$	Input Clamp Voltage	$V_{CC} = 4.5V$ , $I_I = -18\text{ mA}$			-1.2	V	
$V_{OH}$	High Level Output Voltage	$V_{CC} = 4.5V$ $V_{IL} = V_{IL\text{ Max}}$		2.4	3.2	V	
		$V_{CC} = 4.5V$ to $5.5V$	$I_{OH} = \text{Max}$			V	
$V_{OL}$	Low Level Output Voltage	$V_{CC} = 4.5V$ $V_{IH} = 2V$	$I_{OH} = -400\ \mu A$	$V_{CC} - 2$		V	
			$I_{OL} = 12\text{ mA}$		0.25	0.4	V
			$I_{OL} = 24\text{ mA}$		0.35	0.5	V
$I_I$	Input Current @Max Input Voltage	$V_{CC} = 5.5V$ , $V_{IH} = 7V$			0.1	mA	
$I_{IH}$	High Level Input Current	$V_{CC} = 5.5V$ , $V_{IH} = 2.7V$			20	$\mu A$	
$I_{IL}$	Low Level Input Current	$V_{CC} = 5.5V$ , $V_{IL} = 0.4V$			-0.2	mA	
$I_O$	Output Drive Current	$V_{CC} = 5.5V$ , $V_O = 2.25V$	-30		-112	mA	
$I_{OZH}$	Off-State Output Current High Level Voltage Applied	$V_{CC} = 5.5V$ , $V_{IH} = 2V$ $V_O = 2.7V$			20	$\mu A$	
$I_{OZL}$	Off-State Output Current Low Level Voltage Applied	$V_{CC} = 5.5V$ , $V_{IH} = 2V$ $V_O = 0.4V$			-20	$\mu A$	

## Electrical Characteristics (Continued)

over recommended operating free air temperature range. All typical values are measured at  $V_{CC} = 5V$ ,  $T_A = 25^\circ C$ .

Symbol	Parameter	Conditions	Min	Typ	Max	Units	
$I_{CC}$	Supply Current	$V_{CC} = 5.5V$ Outputs Open	Outputs High		14	21	mA
			Outputs Low		19	30	mA
			Outputs Disabled		20	32	mA

## Switching Characteristics

over recommended operating free air temperature range. (Note 4)

Symbol	Parameter	Conditions	From	To	DM74ALS874B		Units
					Min	Max	
$f_{MAX}$	Maximum Clock Frequency	$V_{CC} = 4.5V$ to $5.5V$			30	MHz	
$t_{PLH}$	Propagation Delay Time Low to High Level Output	$R_L = 500\Omega$ , $C_L = 50$ pF	Clock	Any Q	4	14	ns
$t_{PHL}$	Propagation Delay Time High to Low Level Output		Clock	Any Q	4	14	ns
$t_{PZH}$	Output Enable Time to High Level Output		Output Control	Any Q	4	18	ns
$t_{PZL}$	Output Enable Time to Low Level Output		Output Control	Any Q	4	18	ns
$t_{PHZ}$	Output Disable Time from High Level Output		Output Control	Any Q	2	10	ns
$t_{PLZ}$	Output Disable Time from Low Level Output		Output Control	Any Q	3	12	ns
$t_{PHL}$	Propagation Delay Time High to Low Level Output		Clear	Any Q	5	17	ns

**Note 4:** See Section 5 for test waveforms and output load.

## Function Table

Inputs				Output
$\overline{CLR}$	D	CLK	$\overline{OC}$	Q
X	X	X	H	Z
L	X	X	L	L
H	H	↑	L	H
H	L	↑	L	L
H	X	L	L	$Q_0$

L = Low State, H = High State, X = Don't Care  
 ↑ = Positive Edge Transition  
 Z = High Impedance State  
 $Q_0$  = Previous Condition of Q

# Logic Diagram

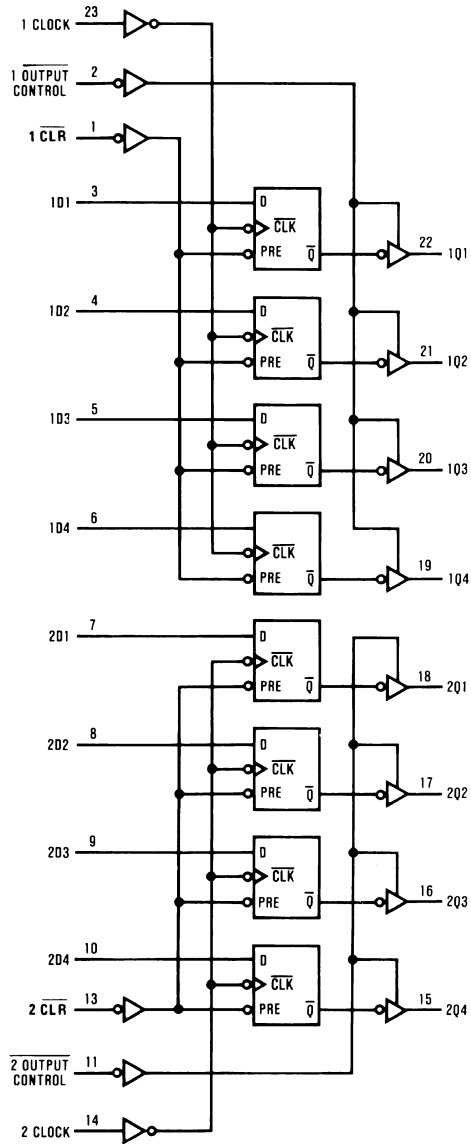

DS006244-2

**Physical Dimensions** inches (millimeters) unless otherwise noted

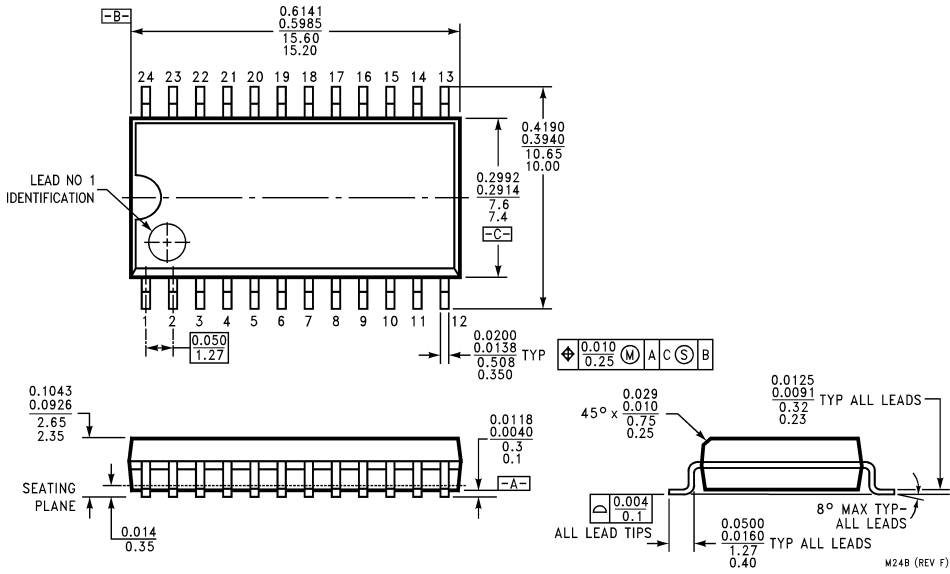

**S.O. Package (M)**  
Order Number DM74ALS874BWM  
Package Number M24B

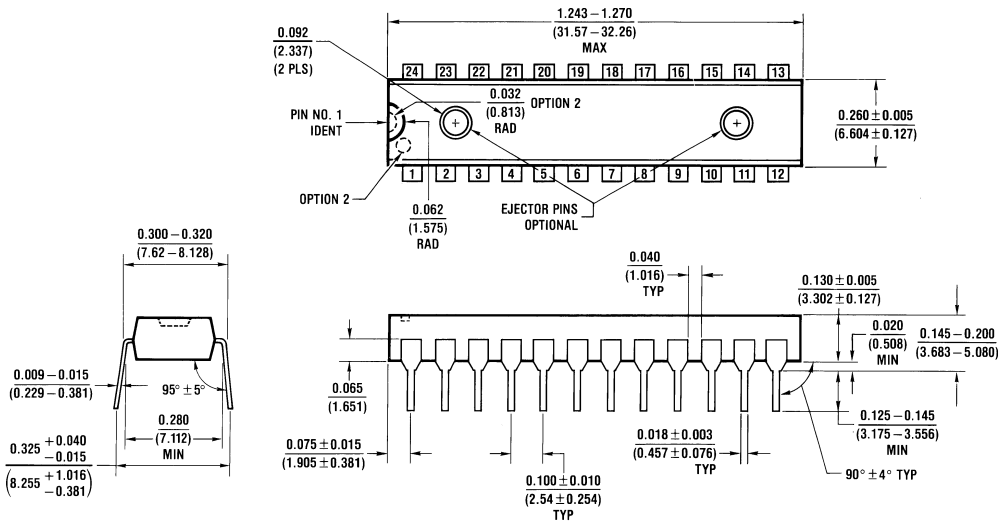

**Skinny Dual-In-Line Package (N)**  
Order Number DM74ALS874BNT  
Package Number N24C

**LIFE SUPPORT POLICY**

FAIRCHILD'S PRODUCTS ARE NOT AUTHORIZED FOR USE AS CRITICAL COMPONENTS IN LIFE SUPPORT DEVICES OR SYSTEMS WITHOUT THE EXPRESS WRITTEN APPROVAL OF THE PRESIDENT OF FAIRCHILD SEMICONDUCTOR CORPORATION. As used herein:

1. Life support devices or systems are devices or systems which, (a) are intended for surgical implant into the body, or (b) support or sustain life, and (c) whose failure to perform when properly used in accordance with instructions for use provided in the labeling, can be reasonably expected to result in a significant injury to the user.
2. A critical component in any component of a life support device or system whose failure to perform can be reasonably expected to cause the failure of the life support device or system, or to affect its safety or effectiveness.

**Fairchild Semiconductor Corporation Americas**  
Customer Response Center  
Tel: 1-888-522-5372

**Fairchild Semiconductor Europe**  
Fax: +49 (0) 1 80-530 85 86  
Email: europe.support@nsc.com  
Deutsch Tel: +49 (0) 8 141-35-0  
English Tel: +44 (0) 1 793-85-68-56  
Italy Tel: +39 (0) 2 57 5631

**Fairchild Semiconductor Hong Kong Ltd.**  
13th Floor, Straight Block,  
Ocean Centre, 5 Canton Rd.  
Tsimshatsui, Kowloon  
Hong Kong  
Tel: +852 2737-7200  
Fax: +852 2314-0061

**National Semiconductor Japan Ltd.**  
Tel: 81-3-5620-6175  
Fax: 81-3-5620-6179

[www.fairchildsemi.com](http://www.fairchildsemi.com)