

## DM74AS169A Synchronous Four Bit Up/Down Counter

### General Description

These synchronous presettable counters feature an internal carry look ahead for cascading in high speed counting applications. The AS169 is a four-bit binary up/down counter. The carry output is decoded to prevent spikes during normal mode of counting operation. Synchronous operation is provided so that outputs change coincident with each other when so instructed by count enable inputs and internal gating. This mode of operation eliminates the output counting spikes which are normally associated with asynchronous (ripple clock) counters. A buffered clock input triggers the four flip-flops on the rising (positive going) edge of clock input waveform.

These counters are fully programmable; that is, the outputs may each be preset either high or low. The load input circuitry allows loading with carry-enable output of cascaded counters. As loading is synchronous, setting up a low level at the load input disables the counter and causes the outputs to agree with the data inputs after the next clock pulse.

The carry look-ahead circuitry permits cascading counters for n-bit synchronous applications without additional gating. Both count enable inputs ( $\bar{P}$  and  $\bar{T}$ ) must be low to count. The direction of the count is determined by the level of the up/down input. When the input is high, the counter counts up; when low, it counts down. Input T is fed forward to enable the carry outputs. The carry output thus enabled will produce a low level output pulse with a duration approximately equal to the high portion of the QA output when counting up, and approximately equal to the low portion of the QA output when

counting down. This low level overflow carry pulse can be used to enable successively cascaded stages. Transitions at the enable  $\bar{P}$  or  $\bar{T}$  inputs are allowed regardless of the level of the clock input.

The control functions for these counters are fully synchronous. Changes at control inputs (enable  $\bar{P}$ , enable  $\bar{T}$ , load, up/down) which modify the operating mode have no effect until clocking occurs. The function of the counter (whether enabled, disabled, loading or counting) will be dictated solely by the conditions meeting the stable setup and hold times.

### Features

- Switching Specifications at 50 pF
- Switching Specifications guaranteed over full temperature and  $V_{CC}$  range
- Advanced oxide-isolated, ion-implanted Schottky TTL process
- Functionally and pin-for-pin compatible with Schottky and low power Schottky TTL counterpart
- Improved AC performance over Schottky and low power Schottky counterparts
- Synchronously programmable
- Internal look ahead for fast counting
- Carry output for n-bit cascading
- Synchronous counting
- Load control line
- ESD inputs

### Connection Diagram

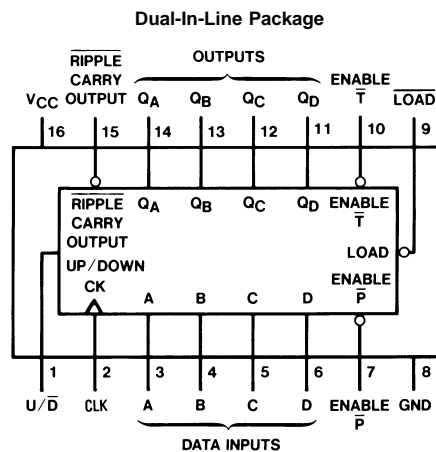

DS006292-1

Order Number DM74AS169AM or DM74AS169AN  
See Package Number M16A or N16A

## Absolute Maximum Ratings (Note 2)

Supply Voltage	7V
Input Voltage	7V
Operating Free Air Temperature Range	0°C to +70°C

Storage Temperature Range -65°C to +150°C

Typical $\theta_{JA}$	
N Package	71.5°C/W
M Package	101.0°C/W

## Recommended Operating Conditions

Symbol	Parameter	Min	Nom	Max	Units
$V_{CC}$	Supply Voltage	4.5	5	5.5	V
$V_{IH}$	High Level Input Voltage	2			V
$V_{IL}$	Low Level Input Voltage			0.8	V
$I_{OH}$	High Level Output Current			-2	mA
$I_{OL}$	Low Level Output Current			20	mA
$f_{CLK}$	Clock Frequency	0		75	MHz
$t_{SU}$	$t_{setup}$ , Set-up Time	Data; A, B, C, D	8		ns
		En $\bar{P}$ , En $\bar{T}$	8		ns
		$\bar{LOAD}$	8		ns
		$U/\bar{D}$	11		ns
$t_H$	$t_{hold}$ , Hold Time	Data; A, B, C, D	0		ns
		En $\bar{P}$ , En $\bar{T}$	0		ns
		$\bar{LOAD}$	0		ns
		$U/\bar{D}$	0		ns
$t_{WCLK}$	Width of Clock Pulse	6.7			ns
$t_A$	Free Air Operating Temperature	0		70	°C

**Note 1:** This product meets application requirements of 500 temperature cycles from -65°C to +150°C.

**Note 2:** The "Absolute Maximum Ratings" are those values beyond which the safety of the device cannot be guaranteed. The device should not be operated at these limits. The parametric values defined in the "Electrical Characteristics" table are not guaranteed at the absolute maximum ratings. The "Recommended Operating Conditions" table will define the conditions for actual device operation.

## Electrical Characteristics

over recommended operating free air temperature range. All typical values are measured at  $V_{CC} = 5V$ ,  $T_A = 25^\circ C$

Symbol	Parameter	Conditions	Min	Typ	Max	Units
$V_{IK}$	Input Clamp Voltage	$V_{CC} = 4.5V$ , $I_I = -18 mA$			-1.2	V
$V_{OH}$	High Level Output Voltage	$I_{OH} = -2 mA$ , $V_{CC} = 4.5V$ to $5.5V$	$V_{CC} - 2$			V
$V_{OL}$	Low Level Output Voltage	$V_{CC} = 4.5V$ , $I_{OL} = 20 mA$		0.35	0.5	V
$I_I$	Input Current @ Max Input Voltage	$V_{CC} = 5.5V$ , $V_{IH} = 7V$	$\bar{LOAD}$ , $\bar{ENT}$ , $U/\bar{D}$		0.2	mA
		Others		0.1		
$I_{IH}$	High Level Input Current	$V_{CC} = 5.5V$ , $V_{IH} = 2.7V$	$\bar{LOAD}$ , $\bar{ENT}$ , $U/\bar{D}$		40	$\mu A$
		Others		20		
$I_{IL}$	Low Level Input Current	$V_{CC} = 5.5V$ , $V_{IL} = 0.4V$	CLK, DATA, EN $\bar{P}$		-0.5	mA
		$\bar{LOAD}$ , $\bar{ENT}$ , $U/\bar{D}$		-1		
$I_O$ (Note 3)	Output Drive Current	$V_{CC} = 5.5V$ , $V_O = 2.25V$	-30		-112	mA
$I_{CC}$	Supply Current	$V_{CC} = 5.5V$		46	63	mA

**Note 3:** The output conditions have been chosen to produce a current that closely approximates one half of the true short circuit output current,  $I_{OS}$ .

## Switching Characteristics

over recommended operating free air temperature range (Note 4)

Symbol	Parameter	Conditions	From	To	Min	Max	Units
$f_{MAX}$	Max. Clock Freq.	$V_{CC} = 4.5V$ to $5.5V$			75		MHz
$t_{PLH}$	Propagation Delay Time Low to High Level Output	$R_L = 500\Omega$ $C_L = 50$ pF	Clock	$\overline{RIPPLE}$ Carry	3	16.5	ns
$t_{PHL}$	Propagation Delay Time High to Low Level Output		Clock	$\overline{RIPPLE}$ Carry	2	13	ns
$t_{PLH}$	Propagation Delay Time Low to High Level Output		Clock	Any Q	1	7	ns
$t_{PHL}$	Propagation Delay Time High to Low Level Output		Clock	Any Q	2	13	ns
$t_{PLH}$	Propagation Delay Time Low to High Level Output		$En \overline{T}$	$\overline{RIPPLE}$ Carry	1.5	9	ns
$t_{PHL}$	Propagation Delay Time High to Low Level Output		$En \overline{T}$	$\overline{RIPPLE}$ Carry	1.5	9	ns
$t_{PLH}$	Propagation Delay Time Low to High Level Output		$U/\overline{D}$ (Note 5)	$\overline{RIPPLE}$ Carry	2	12	ns
$t_{PHL}$	Propagation Delay Time High to Low Level Output		$U/\overline{D}$ (Note 5)	$\overline{RIPPLE}$ Carry	2	13	ns

**Note 4:** See Section 5 for test waveforms and output load.

**Note 5:** Propagation delay time from up/down to ripple carry must be measured with the counter at either a minimum or a maximum count. As the logic level of the up/down input is changed, the ripple carry output will follow. If the count is minimum (0), the ripple carry output transition will be in phase. If the count is maximum (9 for AS168A or 15 for AS169A), the ripple carry output will be out of phase.

# Logic Diagram

AS169A

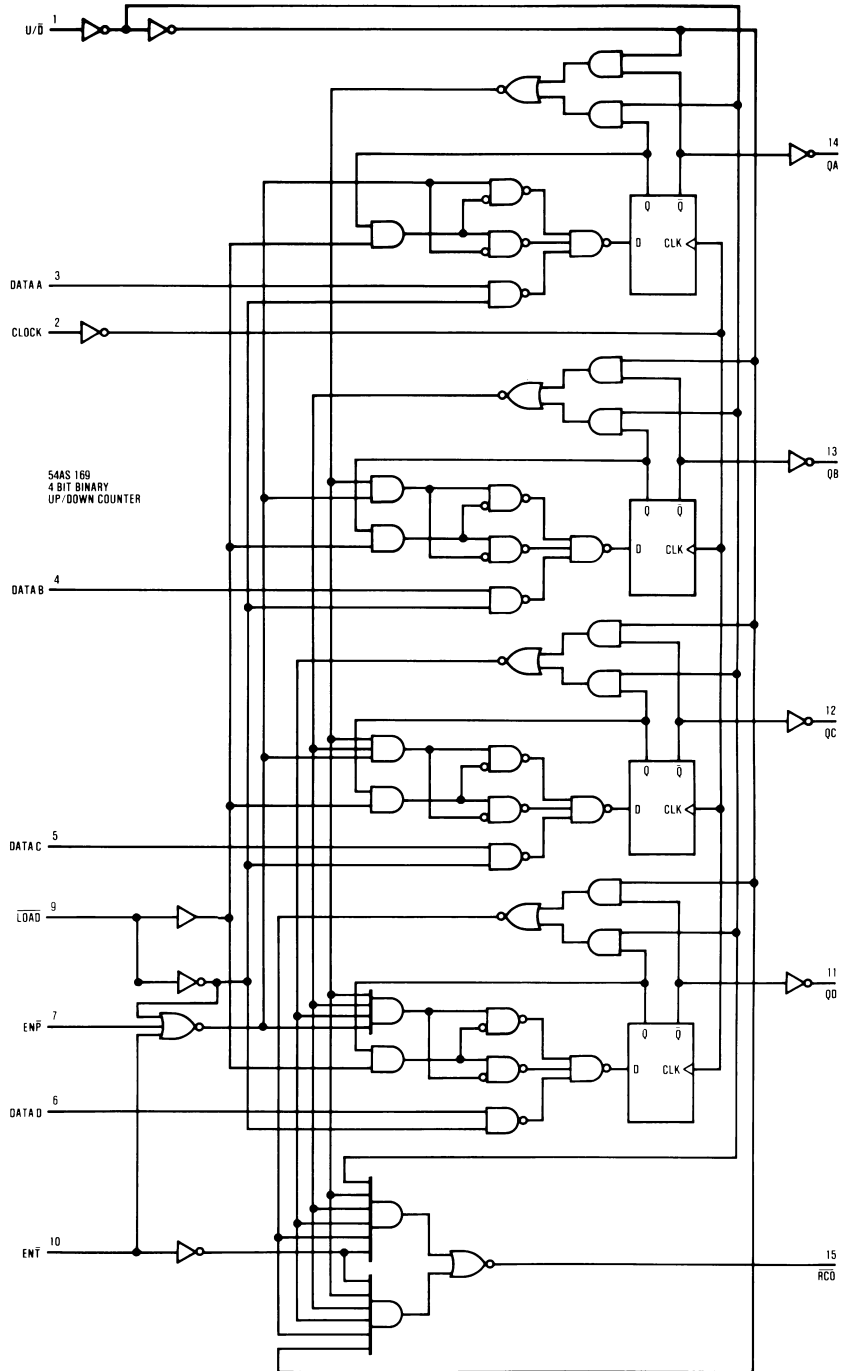

DS006292-3



**LIFE SUPPORT POLICY**

FAIRCHILD'S PRODUCTS ARE NOT AUTHORIZED FOR USE AS CRITICAL COMPONENTS IN LIFE SUPPORT DEVICES OR SYSTEMS WITHOUT THE EXPRESS WRITTEN APPROVAL OF THE PRESIDENT OF FAIRCHILD SEMICONDUCTOR CORPORATION. As used herein:

1. Life support devices or systems are devices or systems which, (a) are intended for surgical implant into the body, or (b) support or sustain life, and (c) whose failure to perform when properly used in accordance with instructions for use provided in the labeling, can be reasonably expected to result in a significant injury to the user.
2. A critical component in any component of a life support device or system whose failure to perform can be reasonably expected to cause the failure of the life support device or system, or to affect its safety or effectiveness.

**Fairchild Semiconductor Corporation Americas**  
Customer Response Center  
Tel: 1-888-522-5372

**Fairchild Semiconductor Europe**  
Fax: +49 (0) 1 80-530 85 86  
Email: europe.support@nsc.com  
Deutsch Tel: +49 (0) 8 141-35-0  
English Tel: +44 (0) 1 793-85-68-56  
Italy Tel: +39 (0) 2 57 5631

**Fairchild Semiconductor Hong Kong Ltd.**  
13th Floor, Straight Block,  
Ocean Centre, 5 Canton Rd.  
Tsimshatsui, Kowloon  
Hong Kong  
Tel: +852 2737-7200  
Fax: +852 2314-0061

**National Semiconductor Japan Ltd.**  
Tel: 81-3-5620-6175  
Fax: 81-3-5620-6179

[www.fairchildsemi.com](http://www.fairchildsemi.com)