

DM74AS257/DM74AS258 3-STATE Quad 1 of 2 Line Data Selector/Multiplexer

General Description

These data selectors/multiplexers contain inverters and drivers to supply full on-chip data selection to the four 3-STATE outputs that can interface directly with data lines of bus-organized systems. A 4-bit word selected from one of two sources is routed to the four outputs. The AS257 presents true data whereas the AS258 presents inverted data to minimize propagation delay time.

This 3-STATE output feature means that n-bit (paralleled) data selectors with up to 300 sources can be implemented for data buses. It also permits the use of standard TTL registers for data retention throughout the system.

Features

- Switching specifications at 50 pF
- Switching specifications guaranteed over full temperature and V_{CC} range

- Advanced oxide-isolated, ion-implanted Schottky TTL process
- Functionally and pin for pin compatible with Schottky, low power Schottky, and advanced low power Schottky TTL counterpart
- Improved AC performance over Schottky, low power Schottky, and advanced low power Schottky counterparts
- 3-STATE buffer-type output drive bus lines directly
- Expand any data input point
- Multiplex dual data buses
- General four functions of two variables (one variable is common)
- Source programmable counters

Connection Diagram

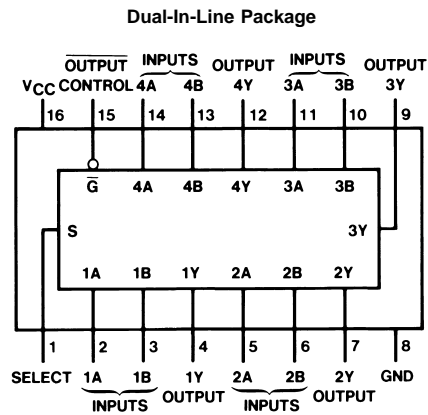

DS006107-1

Order Number DM74AS257M, DM74AS258M, DM74AS257N or DM74AS258N
See Package Number M16A or N16A

Function Table

OUTPUT CONTROL	INPUTS			OUTPUT Y	
	SELECT	A	B	AS257	AS258
H	X	X	X	Z	Z
L	L	L	X	L	H
L	L	H	X	H	L
L	H	X	L	L	H
L	H	X	H	H	L

H = High Level, L = Low Level, X = Don't Care
Z = High Impedance (off)

Absolute Maximum Ratings (Note 1)

Supply Voltage, V_{CC}	7V
Input Voltage	7V
Voltage Applied to Disabled Output	5.5V
Operating Free Air Temperature Range	0°C to +70°C

Storage Temperature Range	-65°C to +150°C
Typical θ_{JA}	75.0°C/W
N Package	

Recommended Operating Conditions

Symbol	Parameter	Min	Nom	Max	Units
V_{CC}	Supply Voltage	4.5	5	5.5	V
V_{IH}	High Level Input Voltage	2			V
V_{IL}	Low Level Input Voltage			0.8	V
I_{OH}	High Level Output Current			-15	mA
I_{OL}	Low Level Output Current			48	mA
T_A	Free Air Operating Temperature	0		70	°C

Note 1: The "Absolute Maximum Ratings" are those values beyond which the safety of the device cannot be guaranteed. The device should not be operated at these limits. The parametric values defined in the "Electrical Characteristics" table are not guaranteed at the absolute maximum ratings. The "Recommended Operating Conditions" table will define the conditions for actual device operation.

Electrical Characteristics

over recommended operating free air temperature range. All typical values are measured at $V_{CC} = 5V$, $T_A = 25^\circ C$.

Symbol	Parameter	Conditions	Min	Typ	Max	Units	
V_{IK}	Input Clamp Voltage	$V_{CC} = 4.5V$, $I_I = -18 mA$			-1.2	V	
V_{OH}	High Level Output Voltage	$V_{CC} = 4.5V$, $I_{OH} = Max$	2.4	3.2		V	
		$I_{OH} = -2 mA$, $V_{CC} = 4.5V$ to 5.5V	$V_{CC} - 2$			V	
V_{OL}	Low Level Output Voltage	$V_{CC} = 4.5V$, $I_{OL} = Max$		0.35	0.5	V	
I_I	Input Current @ Max Input Voltage	$V_{CC} = 5.5V$, $V_{IH} = 7V$	A, B, \bar{G}		0.1	mA	
			Select		0.2		
I_{IH}	High Level Input Current	$V_{CC} = 5.5V$, $V_{IH} = 2.7V$	A, B, \bar{G}		20	μA	
			Select		40		
I_{IL}	Low Level Input Current	$V_{CC} = 5.5V$, $V_{IL} = 0.4V$	Select		-1	mA	
			All Others		-0.5		
I_O (Note 2)	Output Drive Current	$V_{CC} = 5.5V$, $V_O = 2.25V$	-30		-112	mA	
I_{OZH}	Off-State Output Current, High Level Voltage Applied	$V_{CC} = 5.5V$ $V_O = 2.7V$			-50	μA	
I_{OZL}	Off-State Output Current, Low Level Voltage Applied	$V_{CC} = 5.5V$ $V_O = 0.4V$			-50	μA	
I_{CCH}	Supply Current	AS257	Outputs High		12.9	19.7	mA
		AS258			8.8	13.5	mA
I_{CCL}	Supply Current	AS257	Outputs Low		19	30.6	mA
		AS258			15.8	24.6	mA
I_{CCZ}	Supply Current	AS257	Outputs Disabled		19.7	31.9	mA
		AS258			15.5	25.2	mA

Note 2: The output conditions have been chosen to produce a current that closely approximates one half of the true short-circuit output current, I_{OS} .

'AS257 Switching Characteristics

over recommended operating free air temperature range (Note 3)

Symbol	Parameter	From	To	Conditions	Min	Max	Units
t _{PLH}	Propagation Delay Time, Low to High Level Output	Data	Any Y	V _{CC} = 4.5V to 5.5V, C _L = 50 pF, R _L = 500Ω	1	5.5	ns
t _{PHL}	Propagation Delay Time, High to Low Level Output				1	6	ns
t _{PLH}	Propagation Delay Time, Low to High Level Output	Select	Any Y		2	11	ns
t _{PHL}	Propagation Delay Time, High to Low Level Output				2	10	ns
t _{PZH}	Output Enable Time to High Level	OUTPUT Control	Any Y		2	7.5	ns
t _{PZL}	Output Enable Time to Low Level				2	9.5	ns
t _{PHZ}	Output Disable Time, from High Level	OUTPUT Control	Any Y		1.5	6.5	ns
t _{PLZ}	Output Disable Time, from Low Level				2	7	ns

'AS258 Switching Characteristics

over recommended operating free air temperature range (Note 3)

Symbol	Parameter	From	To	Conditions	Min	Max	Units
t _{PLH}	Propagation Delay Time, Low to High Level Output	Data	Any Y	V _{CC} = 4.5V to 5.5V, C _L = 50 pF, R _L = 500Ω	1	5	ns
t _{PHL}	Propagation Delay Time, High to Low Level Output				1	4	ns
t _{PLH}	Propagation Delay Time, Low to High Level Output	Select	Any Y		2	9.5	ns
t _{PHL}	Propagation Delay Time, High to Low Level Output				2	10	ns
t _{PZH}	Output Enable Time to High Level	OUTPUT Control	Any Y		2	8	ns
t _{PZL}	Output Enable Time to Low Level				2	10	ns
t _{PHZ}	Output Disable Time, from High Level	OUTPUT Control	Any Y		1.5	6	ns
t _{PLZ}	Output Disable Time, from Low Level				2	6.5	ns

Note 3: See Section 1 for test waveforms and output load.

Logic Diagrams

AS257

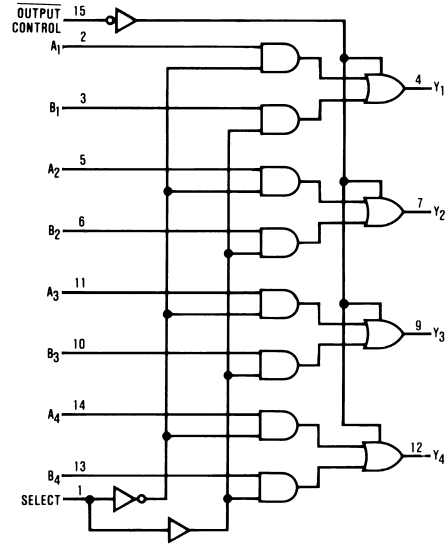

DS006107-2

AS258

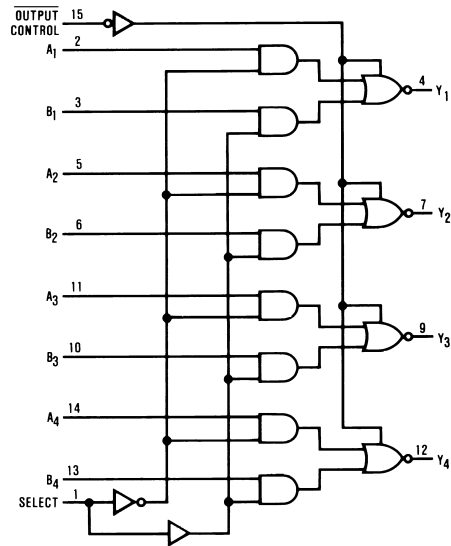

DS006107-3



LIFE SUPPORT POLICY

FAIRCHILD'S PRODUCTS ARE NOT AUTHORIZED FOR USE AS CRITICAL COMPONENTS IN LIFE SUPPORT DEVICES OR SYSTEMS WITHOUT THE EXPRESS WRITTEN APPROVAL OF THE PRESIDENT OF FAIRCHILD SEMICONDUCTOR CORPORATION. As used herein:

1. Life support devices or systems are devices or systems which, (a) are intended for surgical implant into the body, or (b) support or sustain life, and (c) whose failure to perform when properly used in accordance with instructions for use provided in the labeling, can be reasonably expected to result in a significant injury to the user.
2. A critical component in any component of a life support device or system whose failure to perform can be reasonably expected to cause the failure of the life support device or system, or to affect its safety or effectiveness.

Fairchild Semiconductor Corporation Americas
Customer Response Center
Tel: 1-888-522-5372

Fairchild Semiconductor Europe
Fax: +49 (0) 1 80-530 85 86
Email: europe.support@nsc.com
Deutsch Tel: +49 (0) 8 141-35-0
English Tel: +44 (0) 1 793-85-68-56
Italy Tel: +39 (0) 2 57 5631

Fairchild Semiconductor Hong Kong Ltd.
13th Floor, Straight Block,
Ocean Centre, 5 Canton Rd.
Tsimshatsui, Kowloon
Hong Kong
Tel: +852 2737-7200
Fax: +852 2314-0061

National Semiconductor Japan Ltd.
Tel: 81-3-5620-6175
Fax: 81-3-5620-6179

www.fairchildsemi.com