

DM74AS286 9-Bit Parity Generator/Checker with Bus-Driver Parity I/O Port

General Description

These universal, 9-bit parity generators/checkers utilize advanced Schottky high performance circuitry and feature odd/even outputs to facilitate operation of either odd or even parity applications. The word length capability is easily expanded by cascading.

The 'AS286 can be used to upgrade the performance of most systems utilizing the 'AS180, 'AS280 parity generator/checker. Although the 'AS286 is implemented without expander inputs, the corresponding function is provided by the availability of an input pin \overline{XMIT} . \overline{XMIT} is a control line which makes parity error output active and parity an input port when "high"; when "low", parity error output is inactive and parity becomes an output port. In addition, parity I/O control circuitry contains a feature to keep the I/O port in the 3-STATE during power up or down to prevent bus glitches.

Features

- PNP inputs to reduce bus loading
- Generates either odd or even parity for nine data lines
- Inputs are buffered to lower the drive requirements
- Can be used to upgrade existing systems using MSI parity circuits
- Cascadable for n-bits
- Switching specifications at 50 pF
- Switching specifications guaranteed over full temperature and V_{CC} range
- A parity I/O portable to drive bus

Connection Diagram

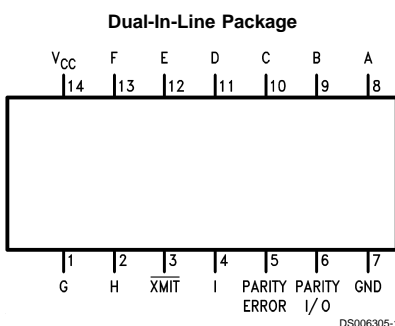

Top View
Order Number DM74AS286M or DM74AS286N
See Package Number M14A or N14A

Function Table

Number of Inputs (A thru I) that are High	Parity I/O		\overline{XMIT}	Parity Error	Mode of Operation
	Input	Output			
0, 2, 4, 6, 8	N/A	H	L	H	Parity Generator
1, 3, 5, 7, 9	N/A	L	L	H	
0, 2, 4, 6, 8	H	N/A	H	H	Parity Checker
0, 2, 4, 6, 8	L	N/A	H	L	
1, 3, 5, 7, 9	H	N/A	H	L	Parity Checker
1, 3, 5, 7, 9	L	N/A	H	H	

L= Low Logic Level H= High Logic Level N/A= Not Applicable

Absolute Maximum Ratings (Note 1)

Supply Voltage	7V
Input Voltage	7V
Operating Free Air Temperature Range	0°C to +70°C

Storage Temperature Range -65°C to +150°C

Typical θ_{JA}	
N Package	77.0°C/W
M Package	108.0°C/W

Recommended Operating Conditions

Symbol	Parameter	Min	Typ	Max	Units
V_{CC}	Supply Voltage	4.5	5	5.5	V
V_{IH}	High Level Input Voltage	2			V
V_{IL}	Low Level Input Voltage			0.8	V
I_{OH}	High Level Output Current	Parity I/O		-15	mA
		Parity Error		-2	mA
I_{OL}	Low Level Output Current	Parity I/O		48	mA
		Parity Error		20	mA
T_A	Operating Free-Air Temperature	0		70	°C

Note 1: The "Absolute Maximum Ratings" are those values beyond which the safety of the device cannot be guaranteed. The device should not be operated at these limits. The parametric values defined in the "Electrical Characteristics" table are not guaranteed at the absolute maximum ratings. The "Recommended Operating Conditions" table will define the conditions for actual device operation.

Electrical Characteristics

over recommended free-air temperature range (Note 2). All typical values are measured at $V_{CC} = 5V$, $T_A = 25^\circ C$.

Symbol	Parameter	Conditions	Min	Typ	Max	Units
V_{IK}	Input Clamp Voltage	$V_{CC} = 4.5V$, $I_{IN} = -18 mA$			-1.2	V
V_{OH}	High Level Output Voltage	$I_{OH} = \text{Max}$, $V_{CC} = 4.5V$	2.4	3.2		V
		$V_{CC} = 4.5V$ to $5.5V$, $I_{OH} = -2 mA$	$V_{CC} - 2$			V
V_{OL}	Low Level Output Voltage	$V_{CC} = 4.5V$, $I_{OL} = \text{Max}$		0.35	0.5	V
I_I	Input Current at Max Input Voltage	$V_{CC} = 5.5V$, $V_{IH} = 7V$ ($V_I = 5.5V$ for Parity I/O)			0.1	mA
I_{IH}	High Level Input Current	$V_{CC} = 5.5V$			20	μA
		$V_{IH} = 2.7V$ (Note 1)	Others		50	
I_{IL}	Low Level Input Current	$V_{CC} = 5.5V$, $V_{IL} = 0.4V$ (Note 1)			-0.5	mA
I_O	Output Drive Current	$V_{CC} = 5.5V$, $V_{OUT} = 2.25V$	-30		-112	mA
I_{CC}	Supply Current	$V_{CC} = 5.5V$, Transmit Mode $\overline{XMIT} = \text{Low}$			43	mA
		Receive Mode			50	mA
		$\overline{XMIT} = \text{High}$				

Note 2: For I/O ports, the parameters I_{IH} and I_{IL} include the off-state current, I_{OZH} and I_{OZL} .

Switching Characteristics

over recommended supply and temperature range (Note 3)

Symbol	Parameter	From	To	Min	Max	Units
t_{PLH}	Propagation Delay Time from Low to High Level Output	Any Data Input	Parity I/O	3	15	ns
t_{PHL}	Propagation Delay Time from High to Low Level Output	Any Data Input	Parity I/O	3	14	ns
t_{PLH}	Propagation Delay Time from Low to High Level Output	Any Data Input	Parity Error	3	16.5	ns

Switching Characteristics (Continued)

over recommended supply and temperature range (Note 3)

Symbol	Parameter	From	To	Min	Max	Units
t _{PHL}	Propagation Delay Time from High to Low Level Output	Any Data Input	Parity Error	3	16.5	ns
t _{PLH}	Propagation Delay Time from Low to High Level Output	Parity I/O	Parity Error	3	9	ns
t _{PHL}	Propagation Delay Time from High to Low Level Output	Parity I/O	Parity Error	3	9	ns
t _{PZL}	Output Enable Time to Low Level	$\overline{\text{XMIT}}$	Parity I/O	3	16	ns
t _{PLZ}	Output Disable Time from Low Level	$\overline{\text{XMIT}}$	Parity I/O	3	10	ns
t _{PZH}	Output Disable Time from High Level	$\overline{\text{XMIT}}$	Parity I/O	3	13	ns
t _{PHZ}	Output Enable Time to High Level	$\overline{\text{XMIT}}$	Parity I/O	3	11.5	ns

Note 3: See Section 1 for test waveforms and output load.

Typical Applications

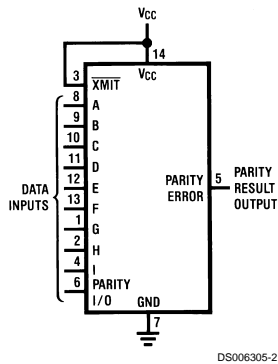

Number of Inputs that are Logic "1"	Parity Result Output
0, 2, 4, 6, 8, 10	Even L
1, 3, 5, 7, 9	Odd H

FIGURE 1. Dedicated 10-Bit Parity Sensing Configuration

Typical Applications (Continued)

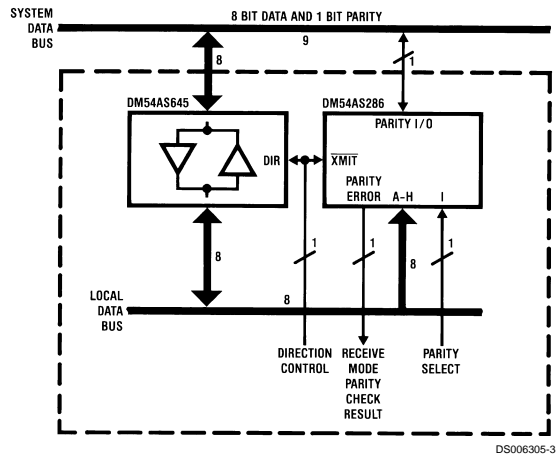

DS006305-3

Direction Control (XMIT)	I/O Direction (Parity I/O)	Parity Check Result (Parity Error)	
		Level	Σ Result
H	Input (Receive)	H	True
		L	False
L	Output (Transmit)	H	N/A

L = Low Logic Level H = High Logic Level N/A = Not Applicable

Parity Select (Input I)	
Level	Format
H	Even
L	Odd

FIGURE 2. Bus I/O Parity Implementation

Typical Applications (Continued)

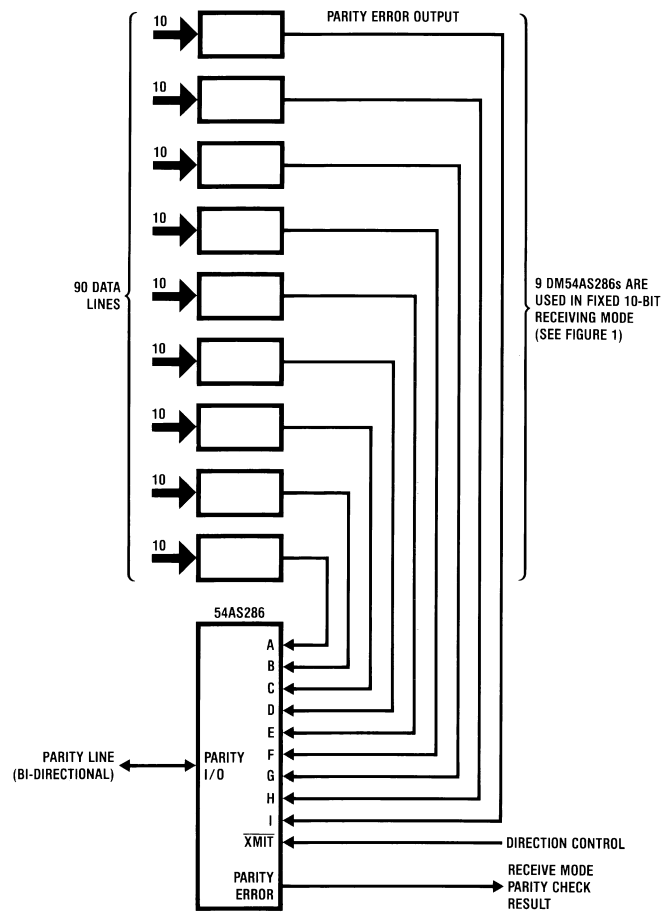

Note: Parity format in this configuration is "odd parity"

FIGURE 3. 90-Bit Parity Generator/Checker Implementation Using Device Expansion Techniques



Physical Dimensions inches (millimeters) unless otherwise noted

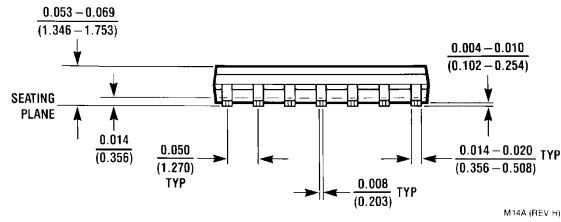
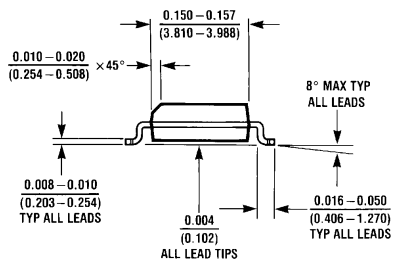
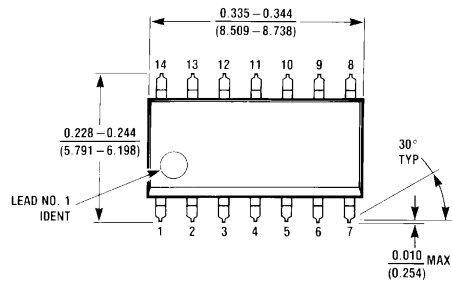

S. O. Package (M)
Order Number DM74AS286M
Package Number M14A

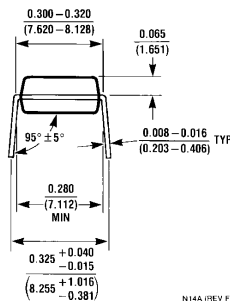
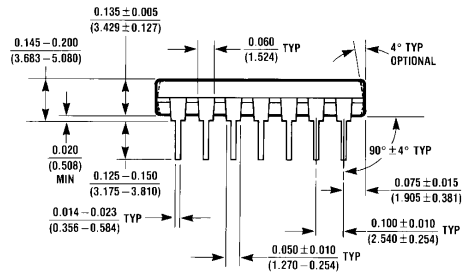
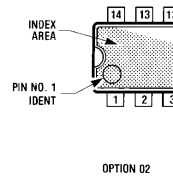
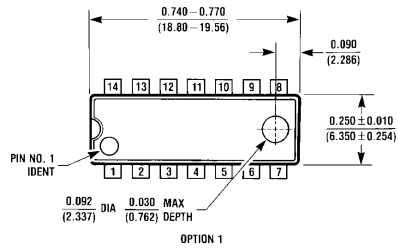

Molded Dual-In-Line Package (N)
Order Number DM74AS286N
Package Number N14A

LIFE SUPPORT POLICY

FAIRCHILD'S PRODUCTS ARE NOT AUTHORIZED FOR USE AS CRITICAL COMPONENTS IN LIFE SUPPORT DEVICES OR SYSTEMS WITHOUT THE EXPRESS WRITTEN APPROVAL OF THE PRESIDENT OF FAIRCHILD SEMICONDUCTOR CORPORATION. As used herein:

1. Life support devices or systems are devices or systems which, (a) are intended for surgical implant into the body, or (b) support or sustain life, and (c) whose failure to perform when properly used in accordance with instructions for use provided in the labeling, can be reasonably expected to result in a significant injury to the user.
2. A critical component in any component of a life support device or system whose failure to perform can be reasonably expected to cause the failure of the life support device or system, or to affect its safety or effectiveness.

Fairchild Semiconductor Corporation Americas
Customer Response Center
Tel: 1-888-522-5372

Fairchild Semiconductor Europe
Fax: +49 (0) 1 80-530 85 86
Email: europe.support@nsc.com
Deutsch Tel: +49 (0) 8 141-35-0
English Tel: +44 (0) 1 793-85-68-56
Italy Tel: +39 (0) 2 57 5631

Fairchild Semiconductor Hong Kong Ltd.
13th Floor, Straight Block,
Ocean Centre, 5 Canton Rd.
Tsimshatsui, Kowloon
Hong Kong
Tel: +852 2737-7200
Fax: +852 2314-0061

National Semiconductor Japan Ltd.
Tel: 81-3-5620-6175
Fax: 81-3-5620-6179

www.fairchildsemi.com