

DM74AS34 Hex Non-Inverter

General Description

These devices contain six independent gates, each of which performs the logic identity function.

- Switching specifications guaranteed over full temperature and V_{CC} range
- Advanced oxide-isolated, ion-implanted Schottky TTL process

Features

- Switching specifications at 50 pF

Connection Diagram

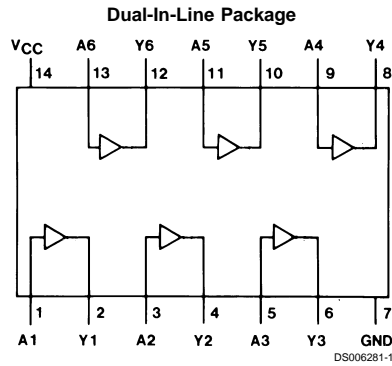

Order Number **DM74AS34N**
See Package Number N14A (Note 1)

Function Table

$$Y = \bar{A}$$

Input A	Output Y
H	H
L	L

H = High Logic Level
L = Low Logic Level

Note 1: Contact your local NSC representative about surface mount (M) package availability.

Absolute Maximum Ratings (Note 2)

Supply Voltage	7V	Range	0°C to +70°C
Input Voltage	7V	Storage Temperature Range	-65°C to +150°C
Operating Free Air Temperature		Typical θ_{JA}	
		N Package	84.5°C/W

Recommended Operating Conditions

Symbol	Parameter	Min	Nom	Max	Units
V _{CC}	Supply Voltage	4.5	5	5.5	V
V _{IH}	High Level Input Voltage	2			V
V _{IL}	Low Level Input Voltage			0.8	V
I _{OH}	High Level Output Current			-2	mA
I _{OL}	Low Level Output Current			20	mA
T _A	Free Air Operating Temperature	0		70	°C

Note 2: The "Absolute Maximum Ratings" are those values beyond which the safety of the device cannot be guaranteed. The device should not be operated at these limits. The parametric values defined in the "Electrical Characteristics" table are not guaranteed at the absolute maximum ratings. The "Recommended Operating Conditions" table will define the conditions for actual device operation.

Electrical Characteristics

over recommended operating free air temperature range. All typical values are measured at V_{CC} = 5V, T_A = 25°C.

Symbol	Parameter	Conditions	Min	Typ	Max	Units	
V _{IK}	Input Clamp Voltage	V _{CC} = 4.5V, I _I = -18 mA			-1.2	V	
V _{OH}	High Level Output Voltage	V _{CC} = 4.5V to 5.5V I _{OH} = -2 mA	V _{CC} - 2			V	
V _{OL}	Low Level Output Voltage	V _{CC} = 4.5V, I _{OL} = 20 mA		0.35	0.5	V	
I _I	Input Current @ Max Input Voltage	V _{CC} = 5.5V, V _{IH} = 7V			0.1	mA	
I _{IH}	High Level Input Current	V _{CC} = 5.5V, V _{IH} = 2.7V			20	μA	
I _{IL}	Low Level Input Current	V _{CC} = 5.5V, V _{IL} = 0.4V			-0.5	mA	
I _O	Output Drive Current	V _{CC} = 5.5V, V _O = 2.25V	-30		-112	mA	
I _{CC}	Supply Current	V _{CC} = 5.5V	Outputs High		7.4	12	mA
			Outputs Low		21.3	34.6	mA

Switching Characteristics

over recommended operating free air temperature range (Note 3)

Symbol	Parameter	Conditions	Min	Max	Units
t _{PLH}	Propagation Delay Time Low to High Level Output	V _{CC} = 4.5V to 5.5V R _L = 500Ω	1	5.5	ns
t _{PHL}	Propagation Delay Time High to Low Level Output	C _L = 50 pF	1	6	ns

Note 3: See Section 1 for test waveforms and output load.



Physical Dimensions inches (millimeters) unless otherwise noted

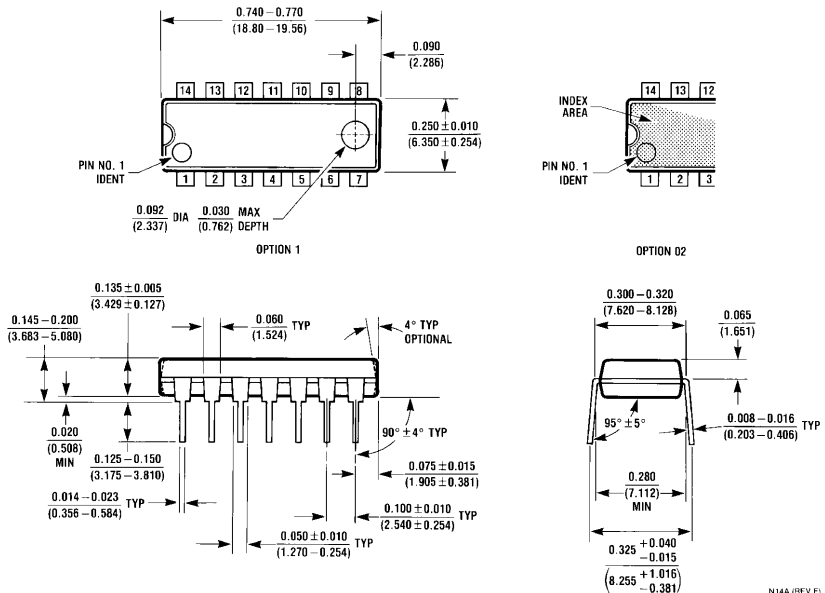

Molded Dual-In-Line Package (N)
Order Number DM74AS34N
Package Number N14A

LIFE SUPPORT POLICY

FAIRCHILD'S PRODUCTS ARE NOT AUTHORIZED FOR USE AS CRITICAL COMPONENTS IN LIFE SUPPORT DEVICES OR SYSTEMS WITHOUT THE EXPRESS WRITTEN APPROVAL OF THE PRESIDENT OF FAIRCHILD SEMICONDUCTOR CORPORATION. As used herein:

1. Life support devices or systems are devices or systems which, (a) are intended for surgical implant into the body, or (b) support or sustain life, and (c) whose failure to perform when properly used in accordance with instructions for use provided in the labeling, can be reasonably expected to result in a significant injury to the user.
2. A critical component in any component of a life support device or system whose failure to perform can be reasonably expected to cause the failure of the life support device or system, or to affect its safety or effectiveness.

<p>Fairchild Semiconductor Corporation Americas Customer Response Center Tel: 1-888-522-5372</p>	<p>Fairchild Semiconductor Europe Fax: +49 (0) 1 80-530 85 86 Email: europe.support@nsc.com Deutsch Tel: +49 (0) 8 141-35-0 English Tel: +44 (0) 1 793-85-68-56 Italy Tel: +39 (0) 2 57 5631</p>	<p>Fairchild Semiconductor Hong Kong Ltd. 13th Floor, Straight Block, Ocean Centre, 5 Canton Rd. Tsimshatsui, Kowloon Hong Kong Tel: +862 2737-7200 Fax: +852 2314-0061</p>	<p>National Semiconductor Japan Ltd. Tel: 81-3-5620-6175 Fax: 81-3-5620-6179</p>
---	--	--	---

www.fairchildsemi.com

Fairchild does not assume any responsibility for use of any circuitry described, no circuit patent licenses are implied and Fairchild reserves the right at any time without notice to change said circuitry and specifications.