

DM74AS640 3-STATE Octal Bus Transceiver

General Description

This advanced Schottky device contains 8 pairs of 3-STATE logic elements configured as octal bus transceiver. This circuit is designed for use in memory, microprocessor systems and in asynchronous bidirectional data buses. This device transmits data from the A bus to the B bus, or vice versa, depending upon the logic level of the direction control input (DIR). The enable input (\bar{G}) can be used to disable the devices, effecting isolation of buses A and B.

The 3-STATE circuitry also contains a protection feature that prevents these transceivers from glitching the bus during power-up or power-down.

Features

- Switching specifications at 50 pF

- Switching specifications guaranteed over full temperature and V_{CC} range
- Advanced oxide-isolated, ion-implanted Schottky TTL process
- Functionally and pin for pin compatible with Schottky, low power Schottky, and advanced low power Schottky TTL counterpart
- Improved AC performance over Schottky, low power Schottky, and advanced low power Schottky counterparts
- 3-STATE outputs independently controlled on A and B buses
- Low output impedance drive to drive terminated transmission lines to 133Ω
- Specified to interface with CMOS at $V_{OH} = V_{CC} - 2V$

Connection Diagram

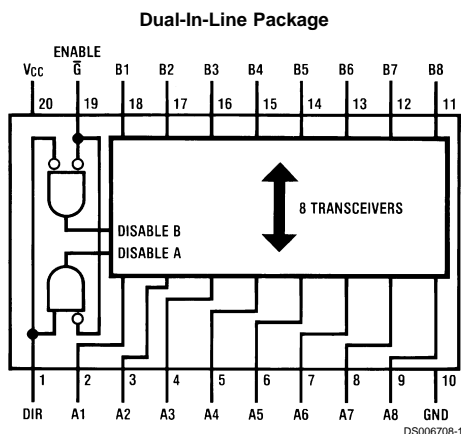

Top View
Order Number DM74AS640N or DM74AS640WM
See Package Number M20B or N20A

Function Table

Control Inputs		Operation
\bar{G}	DIR	
L	L	\bar{B} Data to A Bus
L	H	\bar{A} Data to B Bus
H	X	Isolation

Logic Diagram

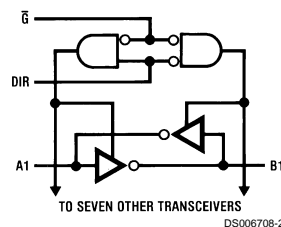

Absolute Maximum Ratings (Note 1)

Supply Voltage	7V	Range	0°C to +70°C
Input Voltage		Storage Temperature Range	-65°C to +150°C
Control Inputs	7V	Typical θ_{JA}	
I/O Ports	5.5V	N Package	51.5°C
Operating Free Air Temperature		M Package	69.0°C

Recommended Operating Conditions

Symbol	Parameter	Min	Typ	Max	Units
V_{CC}	Supply Voltage	4.5	5	5.5	V
V_{IH}	High Level Input Voltage	2			V
V_{IL}	Low Level Input Voltage			0.8	V
I_{OH}	High Level Output Current			-15	mA
I_{OL}	Low Level Output Current			64	mA
T_A	Free Air Operating Temperature	0		70	°C

Note 1: The "Absolute Maximum Ratings" are those values beyond which the safety of the device cannot be guaranteed. The device should not be operated at these limits. The parametric values defined in the "Electrical Characteristics" table are not guaranteed at the absolute maximum ratings. The "Recommended Operating Conditions" table will define the conditions for actual device operation.

Electrical Characteristics

over recommended operating free air temperature range (unless otherwise noted)

Symbol	Parameter	Conditions	Min	Typ (Note 3)	Max	Units
V_I	Input Clamp Voltage	$V_{CC} = \text{Min}, I_I = -18 \text{ mA}$			-1.2	V
V_{OH}	High Level Output Voltage	$V_{CC} = 4.5\text{V to } 5.5\text{V}, I_{OH} = -2 \text{ mA}$	$V_{CC} - 2$			V
		$V_{CC} = 4.5\text{V}, I_{OH} = -3 \text{ mA}$	2.4			V
		$V_{CC} = 4.5\text{V}, I_{OH} = \text{Max}$	2.4			V
V_{OL}	Low Level Output Voltage	$V_{CC} = \text{Min}, I_{OL} = \text{Max}$		0.35	0.55	V
I_I	Input Current at Max Input Voltage	$V_{CC} = \text{Max}, V_I = 7\text{V},$ ($V_I = 5.5\text{V}$ for A or B Ports)			0.1	mA
I_{IH}	High Level Input Current	$V_{CC} = \text{Max}$	Control Inputs		20	μA
		$V_I = 2.7\text{V}$ (Note 4)	A or B Ports		70	
I_{IL}	Low Level Input Current	$V_{CC} = \text{Max},$	Control Inputs		-0.5	mA
		$V_I = 0.4\text{V}$ (Note 4)	A or B Ports		-0.75	
I_O	Output Drive Current	$V_{CC} = \text{Max}, V_O = 2.25\text{V}$	-50		-150	mA
I_{CCH}	Supply Current with Outputs High	$V_{CC} = \text{Max}$		37	58	mA
I_{CCL}	Supply Current with Outputs Low			78	123	mA
I_{CCZ}	Supply Current with Outputs in 3-STATE			51	80	mA

Note 2: This product meets application requirements of 500 temperature cycles from -65°C to +150°C.

Note 3: All typicals are at $V_{CC} = 5.0\text{V}, T_A = 25^\circ\text{C}$.

Note 4: For I/O ports, the parameters I_{IH} and I_{IL} include the off-state output current, I_{OZH} and I_{OZL} .

Switching Characteristics

over recommended operating free air temperature range (unless otherwise noted) (Note 5)

Symbol	Parameter	From (Input)	To (Output)	V _{CC} = Min to Max, C _L = 50 pF, R ₁ = R ₂ = 500Ω		Units
				Min	Max	
t _{PLH}	Propagation Delay Time Low to High Level Output	A or B	B or A	2	7	ns
t _{PHL}	Propagation Delay Time High to Low Level Output	A or B	B or A	2	6	ns
t _{PZH}	Output Enable Time to High Level Output	\overline{G}	A or B	2	8	ns
t _{PZL}	Output Enable Time to Low Level Output	\overline{G}	A or B	2	10	ns
t _{PHZ}	Output Disable Time from High Level Output	\overline{G}	A or B	2	8	ns
t _{PLZ}	Output Disable Time from Low Level Output	\overline{G}	A or B	2	13	ns

Note 5: See Section 5 for test waveforms and output load.



Physical Dimensions inches (millimeters) unless otherwise noted

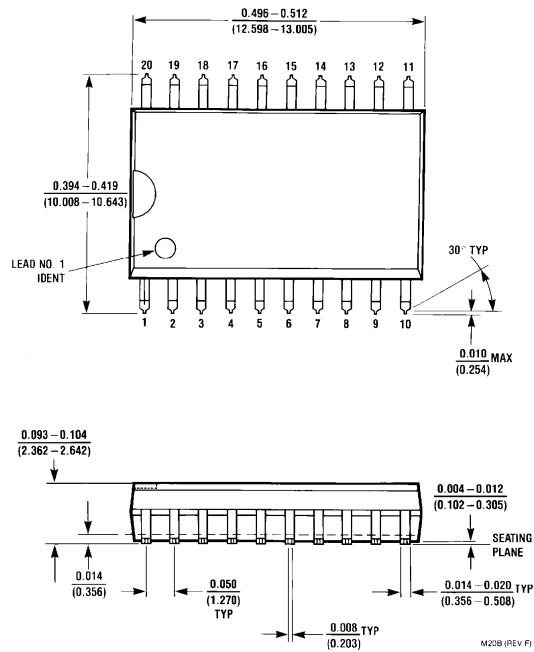

S.O. Package (M)
Order Number DM74AS640WM
Package Number M20B

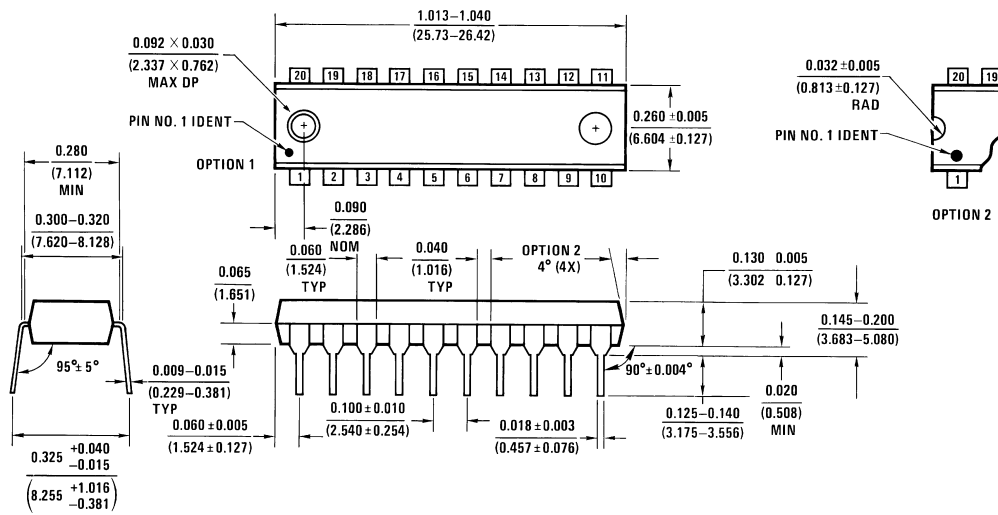

Molded Dual-In-Line Package (N)
Order Number DM74AS640N
Package Number N20A

LIFE SUPPORT POLICY

FAIRCHILD'S PRODUCTS ARE NOT AUTHORIZED FOR USE AS CRITICAL COMPONENTS IN LIFE SUPPORT DEVICES OR SYSTEMS WITHOUT THE EXPRESS WRITTEN APPROVAL OF THE PRESIDENT OF FAIRCHILD SEMICONDUCTOR CORPORATION. As used herein:

1. Life support devices or systems are devices or systems which, (a) are intended for surgical implant into the body, or (b) support or sustain life, and (c) whose failure to perform when properly used in accordance with instructions for use provided in the labeling, can be reasonably expected to result in a significant injury to the user.
2. A critical component in any component of a life support device or system whose failure to perform can be reasonably expected to cause the failure of the life support device or system, or to affect its safety or effectiveness.

Fairchild Semiconductor Corporation Americas
Customer Response Center
Tel: 1-888-522-5372

Fairchild Semiconductor Europe
Fax: +49 (0) 1 80-530 85 86
Email: europe.support@nsc.com
Deutsch Tel: +49 (0) 8 141-35-0
English Tel: +44 (0) 1 793-85-68-56
Italy Tel: +39 (0) 2 57 5631

Fairchild Semiconductor Hong Kong Ltd.
13th Floor, Straight Block,
Ocean Centre, 5 Canton Rd.
Tsimshatsui, Kowloon
Hong Kong
Tel: +852 2737-7200
Fax: +852 2314-0061

National Semiconductor Japan Ltd.
Tel: 81-3-5620-6175
Fax: 81-3-5620-6179

www.fairchildsemi.com