

DM74AS874 Dual 4-Bit D-Type Edge-Triggered Flip-Flop

General Description

These dual 4-bit inverting registers feature totem-pole 3-STATE outputs designed specifically for driving highly-capacitive or relatively low-impedance loads. The high-impedance state and increased high-logic-level drive provide these registers with the capability of being connected directly to and driving the bus lines in a bus-organized system without need for interface or pull-up components. They are particularly attractive for implementing buffer registers, I/O ports, bidirectional bus drivers, and working registers.

The eight flip-flops of the AS874 are edge-triggered D-type flip-flops. On the positive transition of the clock, the Q outputs will be set to the logic states that were set up at the D inputs.

A buffered output control input can be used to place the eight outputs in either a normal logic state (high or low logic levels) or a high-impedance state. In the high-impedance state the outputs neither load nor drive the bus lines significantly.

The output control does not affect the internal operation of the flip-flops. That is, the old data can be retained or new data can be entered even while the outputs are off.

The pinout is arranged to ease printed circuit board layout. All data inputs are on one side of the package, while all outputs are on the other side.

Features

- Switching specifications at 50 pF
- Switching specifications guaranteed over full temperature and V_{CC} range
- Advanced oxide-isolated, ion-implanted Schottky TTL process
- 3-STATE buffer-type outputs drive bus lines directly
- Space saving 300 mil wide package
- Bus structured pinout

Connection Diagram

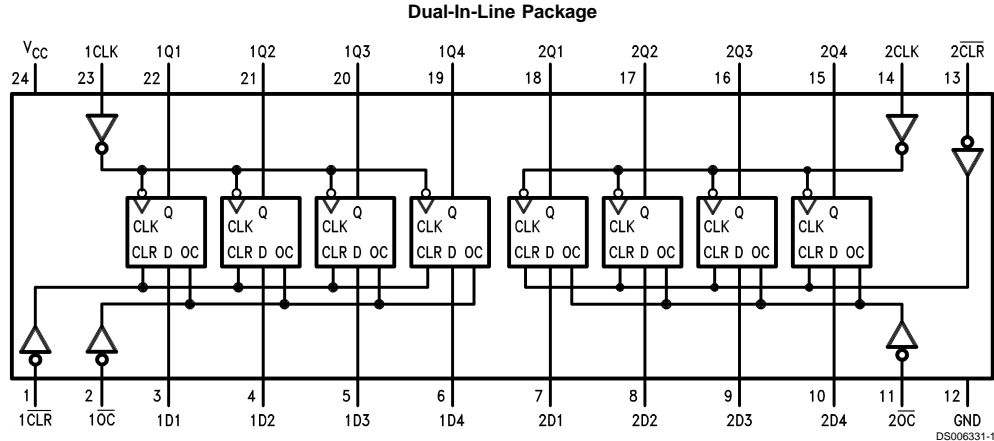

Order Number DM74AS874NT or DM74AS5874WM
See Package Number M24B or N24C

Absolute Maximum Ratings (Note 2)

Supply Voltage	7V
Input Voltage	7V
Voltage Applied to Disabled Output	5.5V
Operating Free Air Temperature Range	0°C to +70°C

Storage Temperature Range

-65°C to +150°C

Typical θ_{JA}

N Package

47.0°C/W

Recommended Operating Conditions

Symbol	Parameter		Min	Nom	Max	Units
V_{CC}	Supply Voltage		4.5	5	5.5	V
V_{IH}	High Level Input Voltage		2			V
V_{IL}	Low Level Input Voltage				0.8	V
I_{OH}	High Level Output Current				-15	mA
I_{OL}	Low Level Output Current				48	mA
f_{CLK}	Clock Frequency		0		80	MHz
t_{WCLK}	Width of Clock Pulse	High	3			ns
		Low	6			
t_{WCLR}	Width of Clear Pulse	Low	2			ns
t_{SU}	Setup Time (Note 3)	Data	4 \uparrow			ns
		Clear Inactive	5 \uparrow			
t_H	Data Hold Time (Note 3)		1 \uparrow			ns
T_A	Free Air Operating Temperature		0		70	°C

Note 1: This product meets application requirements of 500 temperature cycles from -65°C to +150°C.**Note 2:** The "Absolute Maximum Ratings" are those values beyond which the safety of the device cannot be guaranteed. The device should not be operated at these limits. The parametric values defined in the "Electrical Characteristics" table are not guaranteed at the absolute maximum ratings. The "Recommended Operating Conditions" table will define the conditions for actual device operation.**Note 3:** The (\uparrow) arrow indicates the positive edge of the Clock is used for reference.**Electrical Characteristics**over recommended operating free air temperature range. All typical values are measured at $V_{CC} = 5V$, $T_A = 25^\circ C$.

Symbol	Parameter	Conditions	Min	Typ	Max	Units
V_{IK}	Input Clamp Voltage	$V_{CC} = 4.5V$, $I_I = -18\text{ mA}$			-1.2	V
V_{OH}	High Level Output Voltage	$V_{CC} = 4.5V$, $V_{IL} = V_{IL\text{ Max}}$, $I_{OH} = \text{Max}$	2.4	3.3		V
		$I_{OH} = -2\text{ mA}$, $V_{CC} = 4.5V\text{ to }5.5V$	$V_{CC} - 2$			
V_{OL}	Low Level Output Voltage	$V_{CC} = 4.5V$, $V_{IH} = 2V$, $I_{OL} = \text{Max}$		0.35	0.5	V
I_I	Input Current at Max Input Voltage	$V_{CC} = 5.5V$, $V_{IH} = 7V$			0.1	mA
I_{IH}	High Level Input Current	$V_{CC} = 5.5V$, $V_{IH} = 2.7V$			20	μA
I_{IL}	Low Level Input Current	$V_{CC} = 5.5V$, $V_{IL} = 0.4V$			-0.5	mA
I_O (Note 4)	Output Drive Current	$V_{CC} = 5.5V$, $V_O = 2.25V$	-30		-112	mA
I_{OZH}	Off-State Output Current, High Level Voltage Applied	$V_{CC} = 5.5V$, $V_{IH} = 2V$, $V_O = 2.7V$,			50	μA
I_{OZL}	Off-State Output Current, Low Level Voltage Applied	$V_{CC} = 5.5V$, $V_{IH} = 2V$, $V_O = 0.4V$			-50	μA
I_{CC}	Supply Current	$V_{CC} = 5.5V$ Outputs Open	Outputs High	82	133	mA
			Outputs Low	92	149	
			Outputs Disabled	100	160	

Note 4: The output conditions have been chosen to produce a current that closely approximates one-half of the true short-circuit current, I_{OS} .

Switching Characteristics

over recommended operating free air temperature range (Note 5)

Symbol	Parameter	Conditions	From	To	Min	Max	Units
f_{MAX}	Maximum Clock Frequency	$V_{CC} = 4.5V$ to $5.5V$ $R_L = 500\Omega$ $C_L = 50$ pF			80		MHz
t_{PLH}	Propagation Delay Time Low to High Level Output		Clock	Any Q	3	8.5	ns
t_{PHL}	Propagation Delay Time High to Low Level Output		Clock	Any Q	4	10.5	ns
t_{PZH}	Output Enable Time to High Level Output		$\overline{\text{Output}}$ Control	Any Q	2	7	ns
t_{PZL}	Output Enable Time to Low Level Output		$\overline{\text{Output}}$ Control	Any Q	3	10.5	ns
t_{PHZ}	Output Disable Time from High Level Output		$\overline{\text{Output}}$ Control	Any Q	2	6	ns
t_{PLZ}	Output Disable Time from Low Level Output		$\overline{\text{Output}}$ Control	Any Q	2	7.5	ns
t_{PHL}	Propagation Delay Time High to Low Level Output		$\overline{\text{Clear}}$	Any Q	4	11.5	ns

Note 5: See Section 5 for test waveforms and output load.

Function Table

Inputs				Output
$\overline{\text{CLR}}$	D	CLK	$\overline{\text{OC}}$	Q
X	X	X	H	Z
L	X	X	L	L
H	H	↑	L	H
H	L	↑	L	L
H	X	L	L	Q_0

L = Low State, H = High State, X = Don't Care
 ↑ = Positive Edge Transition
 Z = High Impedance State
 Q_0 = Previous Condition of Q

Logic Diagram

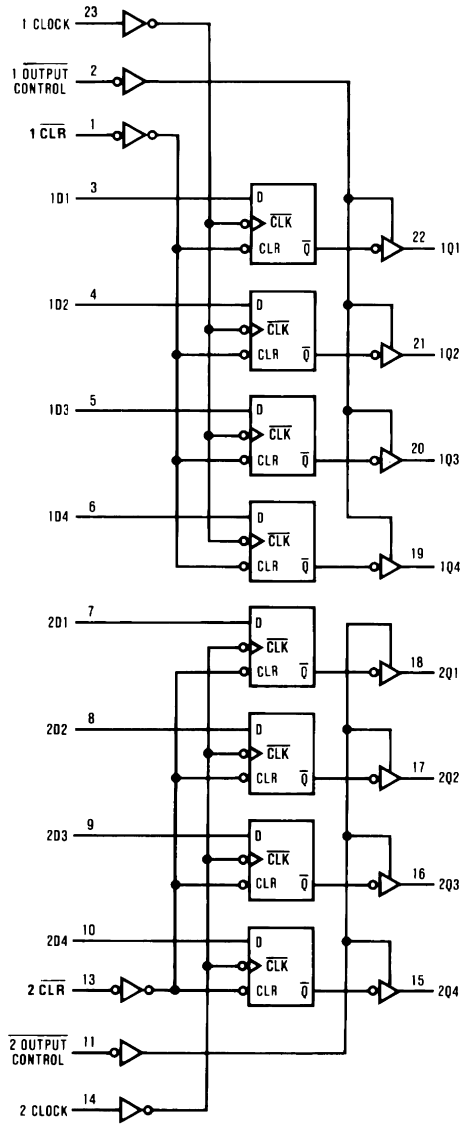

DS006331-2

Physical Dimensions inches (millimeters) unless otherwise noted

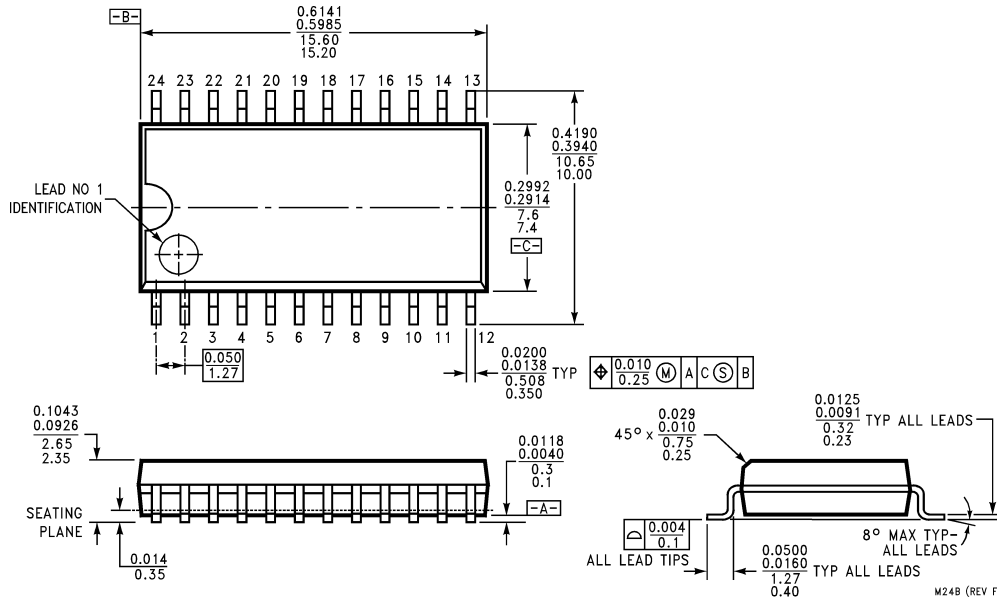

24-Lead (0.300" Wide) Molded Small Outline Package, JEDEC (M)
Order Number DM74AS874WM
Package Number M24B

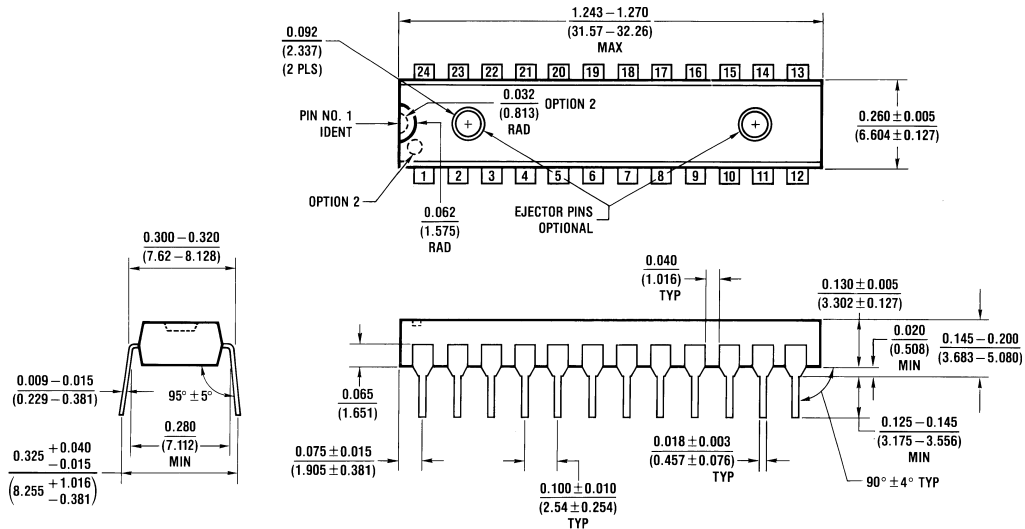

Molded Dual-In-Line Package (N)
Order Number DM74AS874NT
Package Number N24C

LIFE SUPPORT POLICY

FAIRCHILD'S PRODUCTS ARE NOT AUTHORIZED FOR USE AS CRITICAL COMPONENTS IN LIFE SUPPORT DEVICES OR SYSTEMS WITHOUT THE EXPRESS WRITTEN APPROVAL OF THE PRESIDENT OF FAIRCHILD SEMICONDUCTOR CORPORATION. As used herein:

1. Life support devices or systems are devices or systems which, (a) are intended for surgical implant into the body, or (b) support or sustain life, and (c) whose failure to perform when properly used in accordance with instructions for use provided in the labeling, can be reasonably expected to result in a significant injury to the user.
2. A critical component in any component of a life support device or system whose failure to perform can be reasonably expected to cause the failure of the life support device or system, or to affect its safety or effectiveness.

Fairchild Semiconductor Corporation Americas
Customer Response Center
Tel: 1-888-522-5372

Fairchild Semiconductor Europe
Fax: +49 (0) 1 80-530 85 86
Email: europe.support@nsc.com
Deutsch Tel: +49 (0) 8 141-35-0
English Tel: +44 (0) 1 793-85-68-56
Italy Tel: +39 (0) 2 57 5631

Fairchild Semiconductor Hong Kong Ltd.
13th Floor, Straight Block,
Ocean Centre, 5 Canton Rd.
Tsimshatsui, Kowloon
Hong Kong
Tel: +852 2737-7200
Fax: +852 2314-0061

National Semiconductor Japan Ltd.
Tel: 81-3-5620-6175
Fax: 81-3-5620-6179

www.fairchildsemi.com