

## DM74LS155/DM74LS156 Dual 2-Line to 4-Line Decoders/Demultiplexers

### General Description

These TTL circuits feature dual 1-line-to-4-line demultiplexers with individual strobes and common binary-address inputs in a single 16-pin package. When both sections are enabled by the strobes, the common address inputs sequentially select and route associated input data to the appropriate output of each section. The individual strobes permit activating or inhibiting each of the 4-bit sections as desired. Data applied to input C1 is inverted at its outputs and data applied at C2 is true through its outputs. The inverter following the C1 data input permits use as a 3-to-8-line decoder, or 1-to-8-line demultiplexer, without external gating. Input clamping diodes are provided on these circuits to minimize transmission-line effects and simplify system design.

### Features

- Applications:
  - Dual 2-to-4-line decoder
  - Dual 1-to-4-line demultiplexer
  - 3-to-8-line decoder
  - 1-to-8-line demultiplexer
- Individual strobes simplify cascading for decoding or demultiplexing larger words
- Input clamping diodes simplify system design
- Choice of outputs:
  - Totem-pole (LS155)
  - Open-collector (LS156)

### Connection Diagram and Function Tables

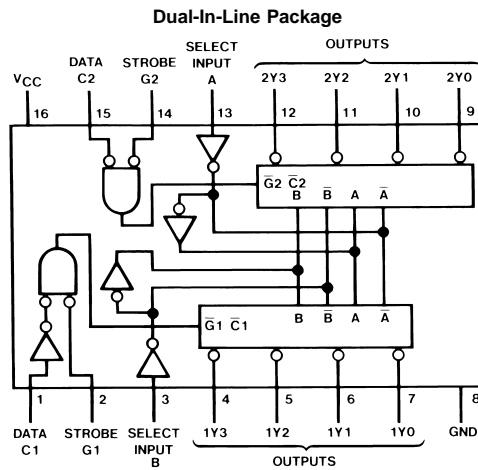

Order Number 54LS155DMQB, 54LS155FMQB, 54LS155LMQB,  
DM54LS155J, DM54LS155W,  
DM74LS155M, DM74LS155N, 54LS156DMQB,  
54LS156FMQB, DM54LS156J, DM54LS156W,  
DM74LS156M or DM74LS156N  
See Package Number E20A, J16A,  
M16A, N16E or W16A

**Connection Diagram and Function Tables** (Continued)

**3-Line-to-8-Line Decoder or  
1-Line-to-8-Line Demultiplexer**

Inputs				Outputs								
Select			Strobe Or Data	(0)	(1)	(2)	(3)	(4)	(5)	(6)	(7)	
C (Note 1)	B	A		G (Note 2)	2Y0	2Y1	2Y2	2Y3	1Y0	1Y1	1Y2	1Y3
X	X	X	H	H	H	H	H	H	H	H	H	H
L	L	L	L	L	H	H	H	H	H	H	H	H
L	L	H	L	L	H	L	H	H	H	H	H	H
L	H	L	L	L	H	H	L	H	H	H	H	H
L	H	H	L	L	H	H	H	L	H	H	H	H
H	L	L	L	L	H	H	H	H	L	H	H	H
H	L	H	L	L	H	H	H	H	H	L	H	H
H	H	L	L	L	H	H	H	H	H	H	L	H
H	H	H	L	L	H	H	H	H	H	H	H	L

**2-Line-to-4-Line Decoder or  
1-Line-to-4-Line Demultiplexer**

Inputs				Outputs			
Select		Strobe	Data	1Y0	1Y1	1Y2	1Y3
B	A	G1	C1				
X	X	H	X	H	H	H	H
L	L	L	H	L	H	H	H
L	H	L	H	H	L	H	H
H	L	L	H	H	H	L	H
H	H	L	H	H	H	H	L
X	X	X	L	H	H	H	H

Inputs				Outputs			
Select		Strobe	Data	2Y0	2Y1	2Y2	2Y3
B	A	G2	C2				
X	X	H	X	H	H	H	H
L	L	L	L	L	H	H	H
L	H	L	L	H	L	H	H
H	L	L	L	H	H	L	H
H	H	L	L	H	H	H	L
X	X	X	H	H	H	H	H

H = high level, L = low level, X = don't care

**Note 1:** C = inputs C1 and C2 connected together

**Note 2:** G = inputs G1 and G2 connected together

## Absolute Maximum Ratings (Note 3)

Supply Voltage	7V	DM54LS and 54LS	-55°C to +125°C
Input Voltage	7V	DM74LS	0°C to +70°C
Operating Free Air Temperature Range		Storage Temperature Range	-65°C to +150°C

## Recommended Operating Conditions

Symbol	Parameter	DM54LS155			DM74LS155			Units
		Min	Nom	Max	Min	Nom	Max	
V <sub>CC</sub>	Supply Voltage	4.5	5	5.5	4.75	5	5.25	V
V <sub>IH</sub>	High Level Input Voltage	2			2			V
V <sub>IL</sub>	Low Level Input Voltage			0.7			0.8	V
V <sub>OH</sub>	High Level Output Current			-0.4			-0.4	mA
I <sub>OL</sub>	Low Level Output Current			4			8	mA
T <sub>A</sub>	Free Air Operating Temperature	-55		125	0		70	°C

**Note 3:** The "Absolute Maximum Ratings" are those values beyond which the safety of the device cannot be guaranteed. The device should not be operated at these limits. The parametric values defined in the "Electrical Characteristics" table are not guaranteed at the absolute maximum ratings. The "Recommended Operating Conditions" table will define the conditions for actual device operation.

## 'LS155 Electrical Characteristics

over recommended operating free air temperature range (unless otherwise noted)

Symbol	Parameter	Conditions	Min	Typ (Note 4)	Max	Units
V <sub>I</sub>	Input Clamp Voltage	V <sub>CC</sub> = Min, I <sub>I</sub> = -18 mA			-1.5	V
V <sub>OH</sub>	High Level Output Voltage	V <sub>CC</sub> = Min, I <sub>OH</sub> = Max	DM54	2.5	3.4	V
		V <sub>IL</sub> = Max, V <sub>IH</sub> = Min	DM74	2.7	3.4	
V <sub>OL</sub>	Low Level Output Voltage	V <sub>CC</sub> = Min, I <sub>OL</sub> = Max	DM54		0.25	0.4
		V <sub>IL</sub> = Max, V <sub>IH</sub> = Min	DM74		0.35	0.5
		I <sub>OL</sub> = 4 mA, V <sub>CC</sub> = Min	DM74		0.25	0.4
I <sub>I</sub>	Input Current @ Max Input Voltage	V <sub>CC</sub> = Max, V <sub>I</sub> = 7V			0.1	mA
I <sub>IH</sub>	High Level Input Current	V <sub>CC</sub> = Max, V <sub>I</sub> = 2.7V			20	μA
I <sub>IL</sub>	Low Level Input Current	V <sub>CC</sub> = Max, V <sub>I</sub> = 0.4V			-0.36	mA
I <sub>OS</sub>	Short Circuit Output Current	V <sub>CC</sub> = Max	DM54	-20		-100
		(Note 5)	DM74	-20		-100
I <sub>CC</sub>	Supply Current	V <sub>CC</sub> = Max (Note 6)		6.1	10	mA

**Note 4:** All typicals are at V<sub>CC</sub> = 5V, T<sub>A</sub> = 25°C.

**Note 5:** Not more than one output should be shorted at a time, and the duration should not exceed one second.

**Note 6:** I<sub>CC</sub> is measured with all outputs open, A, B, and C1 inputs at 4.5V, and C2, G1, and G2 inputs grounded.

## 'LS155 Switching Characteristics

at V<sub>CC</sub> = 5V and T<sub>A</sub> = 25°C

Symbol	Parameter	From (Input) To (Output)	R <sub>L</sub> = 2 kΩ				Units
			C <sub>L</sub> = 15 pF		C <sub>L</sub> = 50 pF		
			Min	Max	Min	Max	
t <sub>PLH</sub>	Propagation Delay Time Low to High Level Output	A, B, C2, G1 or G2 to Y		18		22	ns
t <sub>PHL</sub>	Propagation Delay Time High to Low Level Output	A, B, C2, G1 or G2 to Y		27		35	ns
t <sub>PLH</sub>	Propagation Delay Time Low to High Level Output	A or B to Y		18		24	ns

### 'LS155 Switching Characteristics (Continued)

at  $V_{CC} = 5V$  and  $T_A = 25^\circ C$

Symbol	Parameter	From (Input) To (Output)	$R_L = 2\text{ k}\Omega$				Units
			$C_L = 15\text{ pF}$		$C_L = 50\text{ pF}$		
			Min	Max	Min	Max	
$t_{PHL}$	Propagation Delay Time High to Low Level Output	A or B to Y		27		35	ns
$t_{PLH}$	Propagation Delay Time Low to High Level Output	C1 to Y		20		24	ns
$t_{PHL}$	Propagation Delay Time High to Low Level Output	C1 to Y		27		35	ns

### Recommended Operating Conditions

Symbol	Parameter	DM54LS156			DM74LS156			Units
		Min	Nom	Max	Min	Nom	Max	
$V_{CC}$	Supply Voltage	4.5	5	5.5	4.75	5	5.25	V
$V_{IH}$	High Level Input Voltage	2			2			V
$V_{IL}$	Low Level Input Voltage			0.7			0.8	V
$V_{OH}$	High Level Output Voltage			5.5			5.5	V
$I_{OL}$	Low Level Output Current			4			8	mA
$T_A$	Free Air Operating Temperature	-55		125	0		70	$^\circ C$

### 'LS156 Electrical Characteristics

over recommended operating free air temperature range (unless otherwise noted)

Symbol	Parameter	Conditions	Min	Typ (Note 7)	Max	Units
$V_I$	Input Clamp Voltage	$V_{CC} = \text{Min}, I_I = -18\text{ mA}$			-1.5	V
$I_{CEX}$	High Level Output Current	$V_{CC} = \text{Min}, V_O = 5.5V$ $V_{IL} = \text{Max}, V_{IH} = \text{Min}$			100	$\mu A$
$V_{OL}$	Low Level Output Voltage	$V_{CC} = \text{Min}, I_{OL} = \text{Max}$	DM54	0.25	0.4	V
		$V_{IL} = \text{Max}, V_{IH} = \text{Min}$	DM74	0.35	0.5	
		$I_{OL} = 4\text{ mA}, V_{CC} = \text{Min}$	DM74	0.25	0.4	
$I_I$	Input Current @ Max Input Voltage	$V_{CC} = \text{Max}, V_I = 7V$			0.1	mA
$I_{IH}$	High Level Input Current	$V_{CC} = \text{Max}, V_I = 2.7V$			20	$\mu A$
$I_{IL}$	Low Level Input Current	$V_{CC} = \text{Max}, V_I = 0.4V$			-0.36	mA
$I_{CC}$	Supply Current	$V_{CC} = \text{Max}$ (Note 8)		6.1	10	mA

**Note 7:** All typicals are at  $V_{CC} = 5V, T_A = 25^\circ C$ .

**Note 8:**  $I_{CC}$  is measured with all outputs open, A, B, and C1 inputs at 4.5V, and C2, G1, and G2 grounded.

### 'LS156 Switching Characteristics

at  $V_{CC} = 5V$  and  $T_A = 25^\circ C$

Symbol	Parameter	From (Input) To (Output)	$R_L = 2\text{ k}\Omega$				Units
			$C_L = 15\text{ pF}$		$C_L = 50\text{ pF}$		
			Min	Max	Min	Max	
$t_{PLH}$	Propagation Delay Time Low to High Level Output	A, B, C2, G1 or G2 to Y		28		53	ns
$t_{PHL}$	Propagation Delay Time High to Low Level Output	A, B, C2, G1 or G2 to Y		33		43	ns

## 'LS156 Switching Characteristics (Continued)

at  $V_{CC} = 5V$  and  $T_A = 25^\circ C$

Symbol	Parameter	From (Input) To (Output)	$R_L = 2\text{ k}\Omega$				Units
			$C_L = 15\text{ pF}$		$C_L = 50\text{ pF}$		
			Min	Max	Min	Max	
$t_{PLH}$	Propagation Delay Time Low to High Level Output	A or B to Y		28		53	ns
$t_{PHL}$	Propagation Delay Time High to Low Level Output	A or B to Y		33		43	ns
$t_{PLH}$	Propagation Delay Time Low to High Level Output	C1 to Y		28		53	ns
$t_{PHL}$	Propagation Delay Time High to Low Level Output	C1 to Y		34		43	ns

## Logic Diagram

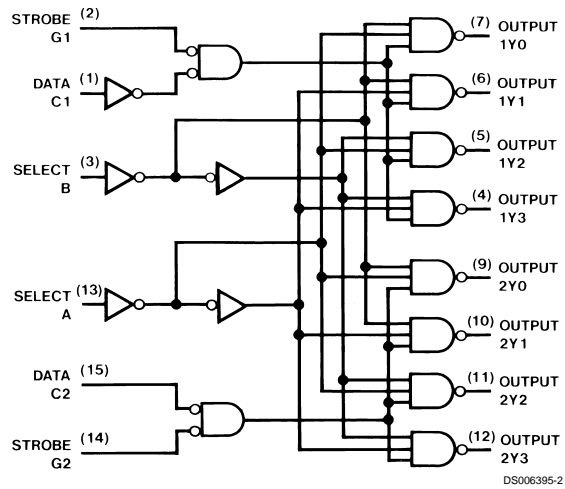

**Physical Dimensions** inches (millimeters) unless otherwise noted

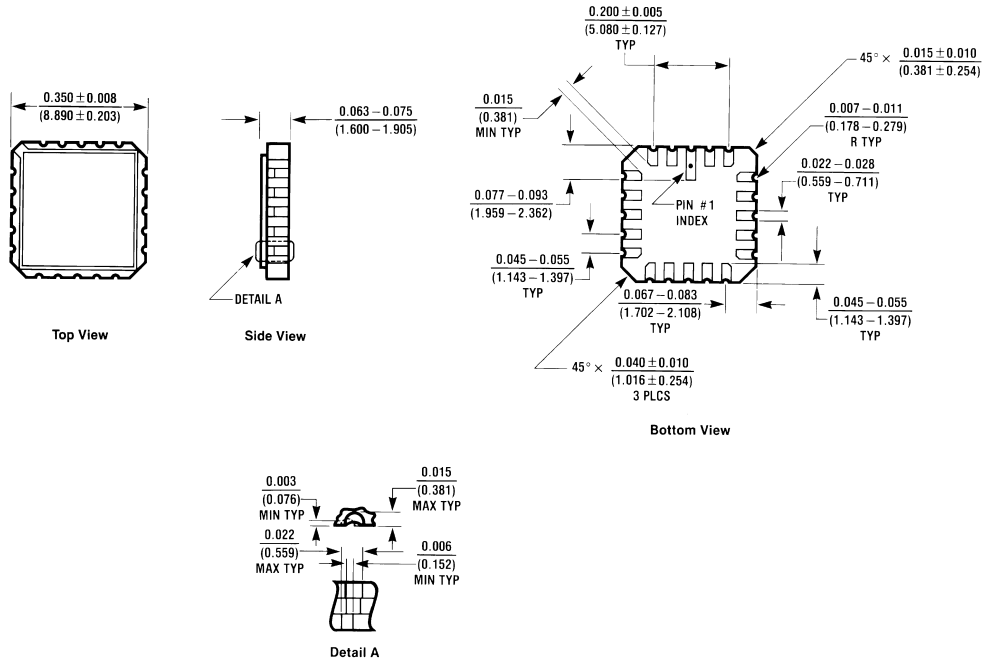

E20A (REV D)

**Ceramic Leadless Chip Carrier (E)**  
**Order Number 54LS155LMBQ**  
**Package Number E20A**

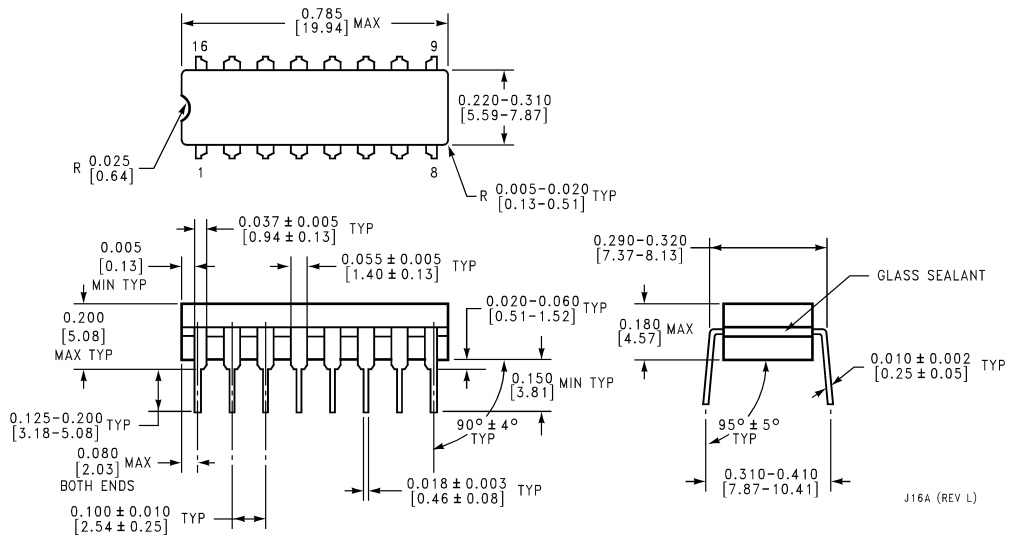

J16A (REV L)

**16-Lead Ceramic Dual-In-Line Package (J)**  
**Order Number 54LS155DMQB, 54LS156DMQB, DM54LS155J or DM54LS156J**  
**Package Number J16A**

**Physical Dimensions** inches (millimeters) unless otherwise noted (Continued)

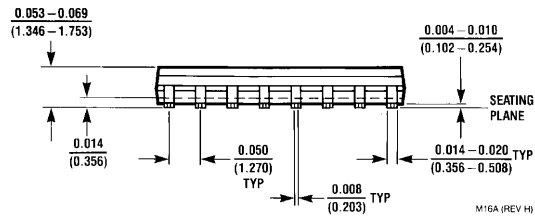
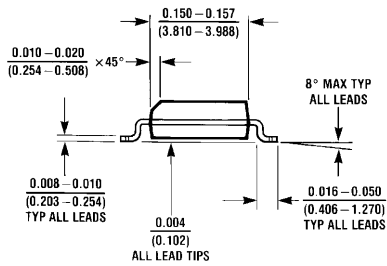
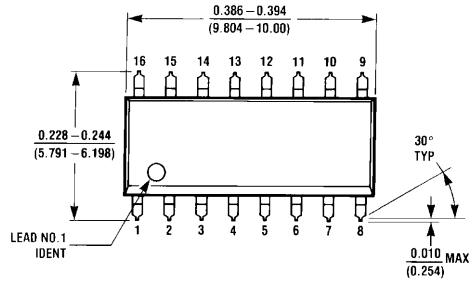

**16-Lead Small Outline Molded Package (M)**  
**Order Number DM74LS155M or DM74LS156M**  
**Package Number M16A**

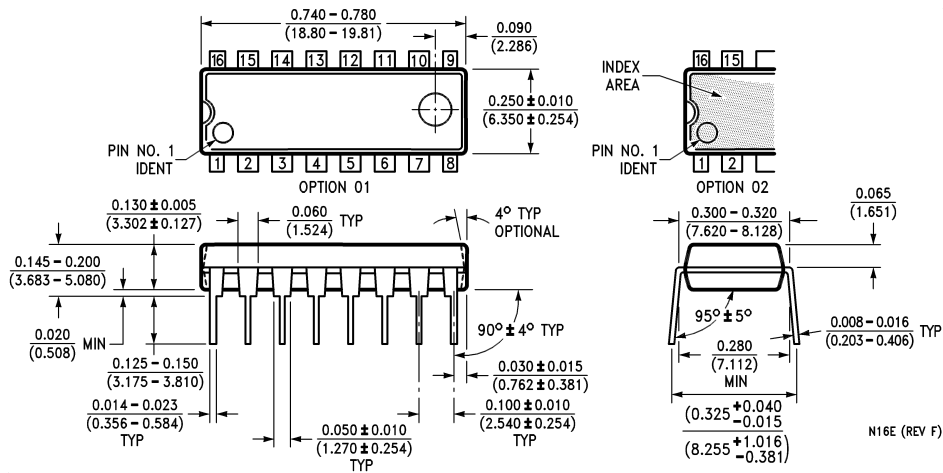

**16-Lead Molded Dual-In-Line Package (N)**  
**Order Number DM74LS155N or DM74LS156N**  
**Package Number N16E**

**Physical Dimensions** inches (millimeters) unless otherwise noted (Continued)

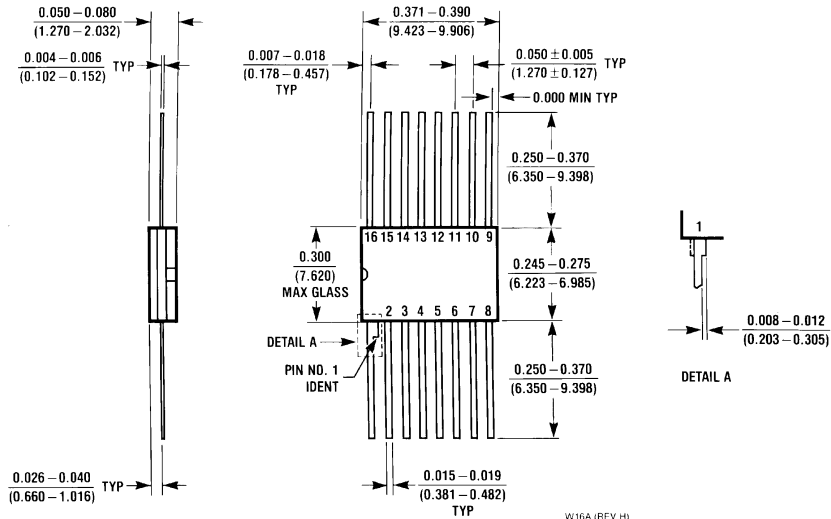

**16-Lead Ceramic Flat Package (W)**  
**Order Number 54LS155FMQB, 54LS156FMQB, DM54LS155W or DM54LS156W**  
**Package Number W16A**

**LIFE SUPPORT POLICY**

FAIRCHILD'S PRODUCTS ARE NOT AUTHORIZED FOR USE AS CRITICAL COMPONENTS IN LIFE SUPPORT DEVICES OR SYSTEMS WITHOUT THE EXPRESS WRITTEN APPROVAL OF THE PRESIDENT OF FAIRCHILD SEMICONDUCTOR CORPORATION. As used herein:

1. Life support devices or systems are devices or systems which, (a) are intended for surgical implant into the body, or (b) support or sustain life, and (c) whose failure to perform when properly used in accordance with instructions for use provided in the labeling, can be reasonably expected to result in a significant injury to the user.
2. A critical component in any component of a life support device or system whose failure to perform can be reasonably expected to cause the failure of the life support device or system, or to affect its safety or effectiveness.

**Fairchild Semiconductor Corporation Americas**  
 Customer Response Center  
 Tel: 1-888-522-5372

**Fairchild Semiconductor Europe**  
 Fax: +49 (0) 1 80-530 85 86  
 Email: europe.support@nsc.com  
 Deutsch Tel: +49 (0) 8 141-35-0  
 English Tel: +44 (0) 1 793-85-68-56  
 Italy Tel: +39 (0) 2 57 5631

**Fairchild Semiconductor Hong Kong Ltd.**  
 13th Floor, Straight Block,  
 Ocean Centre, 5 Canton Rd.  
 Tsimshatsui, Kowloon  
 Hong Kong  
 Tel: +862 2737-7200  
 Fax: +852 2314-0061

**National Semiconductor Japan Ltd.**  
 Tel: 81-3-5620-6175  
 Fax: 81-3-5620-6179

[www.fairchildsemi.com](http://www.fairchildsemi.com)