

DM74LS157/DM74LS158 Quad 2-Line to 1-Line Data Selectors/Multiplexers

General Description

These data selectors/multiplexers contain inverters and drivers to supply full on-chip data selection to the four output gates. A separate strobe input is provided. A 4-bit word is selected from one of two sources and is routed to the four outputs. The LS157 presents true data whereas the LS158 presents inverted data to minimize propagation delay time.

Applications

- Expand any data input point
- Multiplex dual data buses
- Generate four functions of two variables (one variable is common)

- Source programmable counters

Features

- Buffered inputs and outputs
- Typical Propagation Time
 - LS157 9 ns
 - LS158 7 ns
- Typical Power Dissipation
 - LS157 49 mW
 - LS158 24 mW

Connection Diagrams

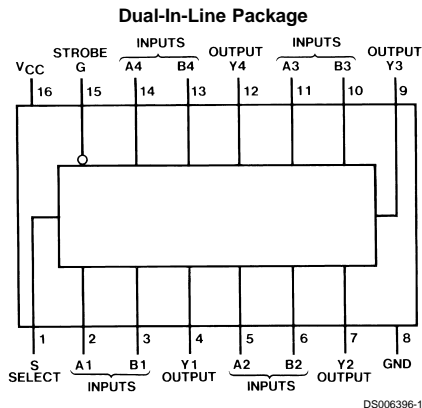

Order Number 54LS157DMQB, 54LS157FMQB, 54LS157LMQB, DM54LS157J, DM54LS157W, DM74LS157M or DM74LS157N
See Package Number E20A, J16A, M16A, N16E or W16A

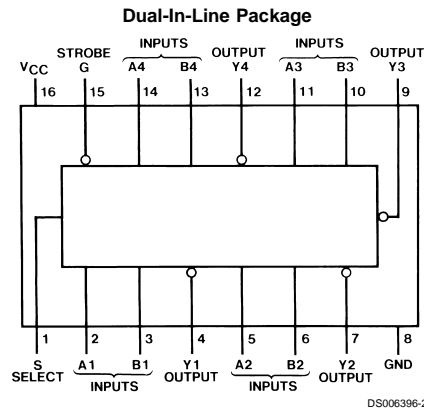

Order Number 54LS158DMQB, 54LS158FMQB, 54LS158LMQB, DM54LS158J, DM54LS158W, DM74LS158M or DM74LS158N
See Package Number E20A, J16A, M16A, N16E or W16A

Function Table

Inputs				Output Y	
Strobe	Select	A	B	LS157	LS158
H	X	X	X	L	H
L	L	L	X	L	H
L	L	H	X	H	L
L	H	X	L	L	H
L	H	X	H	H	L

H = High Level, L = Low Level, X = Don't Care

Absolute Maximum Ratings (Note 1)

Supply Voltage	7V	DM54LS and 54LS	-55°C to +125°C
Input Voltage	7V	DM74LS	0°C to +70°C
Operating Free Air Temperature Range		Storage Temperature Range	-65°C to +150°C

Recommended Operating Conditions

Symbol	Parameter	DM54LS157			DM74LS157			Units
		Min	Nom	Max	Min	Nom	Max	
V _{CC}	Supply Voltage	4.5	5	5.5	4.75	5	5.25	V
V _{IH}	High Level Input Voltage	2			2			V
V _{IL}	Low Level Input Voltage			0.7			0.8	V
I _{OH}	High Level Output Current			-0.4			-0.4	mA
I _{OL}	Low Level Output Current			4			8	mA
T _A	Free Air Operating Temperature	-55		125	0		70	°C

Note 1: The "Absolute Maximum Ratings" are those values beyond which the safety of the device cannot be guaranteed. The device should not be operated at these limits. The parametric values defined in the "Electrical Characteristics" table are not guaranteed at the absolute maximum ratings. The "Recommended Operating Conditions" table will define the conditions for actual device operation.

'LS157 Electrical Characteristics

over recommended operating free air temperature range (unless otherwise noted)

Symbol	Parameter	Conditions	Min	Typ (Note 2)	Max	Units	
V _I	Input Clamp Voltage	V _{CC} = Min, I _I = -18 mA			-1.5	V	
V _{OH}	High Level Output Voltage	V _{CC} = Min, I _{OH} = Max V _{IL} = Max, V _{IH} = Min	DM54	2.5	3.4	V	
			DM74	2.7	3.4		
V _{OL}	Low Level Output Voltage	V _{CC} = Min, I _{OL} = Max V _{IL} = Max, V _{IH} = Min I _{OL} = 4 mA, V _{CC} = Min	DM54		0.25	0.4	V
			DM74		0.35	0.5	
			DM74		0.25	0.4	
I _I	Input Current @ Max Input Voltage	V _{CC} = Max V _I = 7V	S or G		0.2	mA	
			A or B		0.1		
I _{IH}	High Level Input Current	V _{CC} = Max V _I = 2.7V	S or G		40	µA	
			A or B		20		
I _{IL}	Low Level Input Current	V _{CC} = Max V _I = 0.4V	S or G		-0.8	mA	
			A or B		-0.4		
I _{OS}	Short Circuit Output Current	V _{CC} = Max (Note 3)	DM54	-20	-100	mA	
			DM74	-20	-100		
I _{CC}	Supply Current	V _{CC} = Max (Note 4)		9.7	16	mA	

Note 2: All typicals are at V_{CC} = 5V, T_A = 25°C.

Note 3: Not more than one output should be shorted at a time, and the duration should not exceed one second.

Note 4: I_{CC} is measured with 4.5V applied to all inputs and all outputs open.

'LS157 Switching Characteristics

at V_{CC} = 5V and T_A = 25°C

Symbol	Parameter	From (Input) To (Output)	R _L = 2 kΩ				Units
			C _L = 15 pF		C _L = 50 pF		
			Min	Max	Min	Max	
t _{PLH}	Propagation Delay Time Low to High Level Output	Data to Y		14		18	ns
t _{PHL}	Propagation Delay Time High to Low Level Output	Data to Y		14		23	ns

'LS157 Switching Characteristics (Continued)

at $V_{CC} = 5V$ and $T_A = 25^\circ C$

Symbol	Parameter	From (Input) To (Output)	$R_L = 2\text{ k}\Omega$				Units
			$C_L = 15\text{ pF}$		$C_L = 50\text{ pF}$		
			Min	Max	Min	Max	
t_{PLH}	Propagation Delay Time Low to High Level Output	Strobe to Y		20		24	ns
t_{PHL}	Propagation Delay Time High to Low Level Output	Strobe to Y		21		30	ns
t_{PLH}	Propagation Delay Time Low to High Level Output	Select to Y		23		28	ns
t_{PHL}	Propagation Delay Time High to Low Level Output	Select to Y		27		32	ns

Recommended Operating Conditions

Symbol	Parameter	DM54LS158			DM74LS158			Units
		Min	Nom	Max	Min	Nom	Max	
V_{CC}	Supply Voltage	4.5	5	5.5	4.75	5	5.25	V
V_{IH}	High Level Input Voltage	2			2			V
V_{IL}	Low Level Input Voltage			0.7			0.8	V
I_{OH}	High Level Output Current			-0.4			-0.4	mA
I_{OL}	Low Level Output Current			4			8	mA
T_A	Free Air Operating Temperature	-55		125	0		70	$^\circ C$

'LS158 Electrical Characteristics

over recommended operating free air temperature range (unless otherwise noted)

Symbol	Parameter	Conditions	Min	Typ (Note 5)	Max	Units	
V_I	Input Clamp Voltage	$V_{CC} = \text{Min}, I_I = -18\text{ mA}$			-1.5	V	
V_{OH}	High Level Output Voltage	$V_{CC} = \text{Min}, I_{OH} = \text{Max}$ $V_{IL} = \text{Max}, V_{IH} = \text{Min}$	DM54	2.5	3.4	V	
			DM74	2.7	3.4		
V_{OL}	Low Level Output Voltage	$V_{CC} = \text{Min}, I_{OL} = \text{Max}$ $V_{IL} = \text{Max}, V_{IH} = \text{Min}$ $I_{OL} = 4\text{ mA}, V_{CC} = \text{Min}$	DM54		0.25	0.4	V
			DM74		0.35	0.5	
			DM74		0.25	0.4	
I_I	Input Current @ Max Input Voltage	$V_{CC} = \text{Max}$ $V_I = 7V$	S or G		0.2	mA	
			A or B		0.1		
I_{IH}	High Level Input Current	$V_{CC} = \text{Max}$ $V_I = 2.7V$	S or G		40	μA	
			A or B		20		
I_{IL}	Low Level Input Current	$V_{CC} = \text{Max}$ $V_I = 0.4V$	S or G		-0.8	mA	
			A or B		-0.4		
I_{OS}	Short Circuit Output Current	$V_{CC} = \text{Max}$ (Note 6)	DM54	-20	-100	mA	
			DM74	-20	-100		
I_{CC}	Supply Current	$V_{CC} = \text{Max}$ (Note 7)		4.8	8	mA	

Note 5: All typicals are at $V_{CC} = 5V, T_A = 25^\circ C$.

Note 6: Not more than one output should be shorted at a time, and the duration should not exceed one second.

Note 7: I_{CC} is measured with 4.5V applied to all inputs and all outputs open.

'LS158 Switching Characteristics

at $V_{CC} = 5V$ and $T_A = 25^\circ C$

Symbol	Parameter	From (Input) To (Output)	$R_L = 2\text{ k}\Omega$				Units
			$C_L = 15\text{ pF}$		$C_L = 50\text{ pF}$		
			Min	Max	Min	Max	
t_{PLH}	Propagation Delay Time Low to High Level Output	Data to Y		12		18	ns
t_{PHL}	Propagation Delay Time High to Low Level Output	Data to Y		12		21	ns
t_{PLH}	Propagation Delay Time Low to High Level Output	Strobe to Y		17		23	ns
t_{PHL}	Propagation Delay Time High to Low Level Output	Strobe to Y		18		28	ns
t_{PLH}	Propagation Delay Time Low to High Level Output	Select to Y		20		24	ns
t_{PHL}	Propagation Delay Time High to Low Level Output	Select to Y		24		36	ns

Logic Diagrams

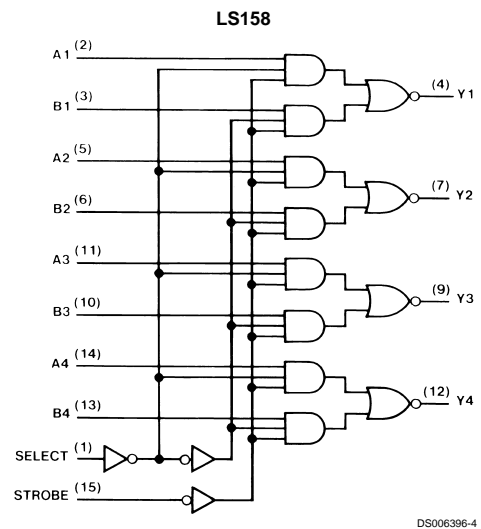
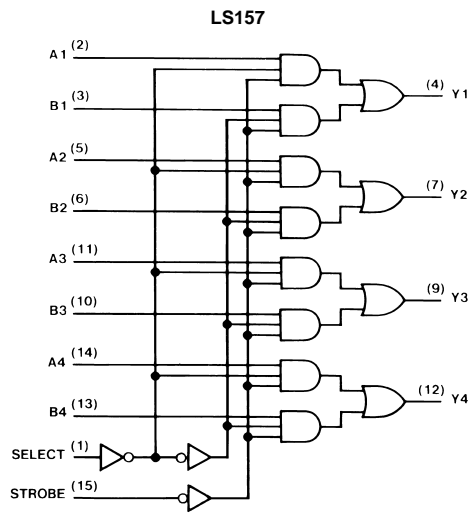

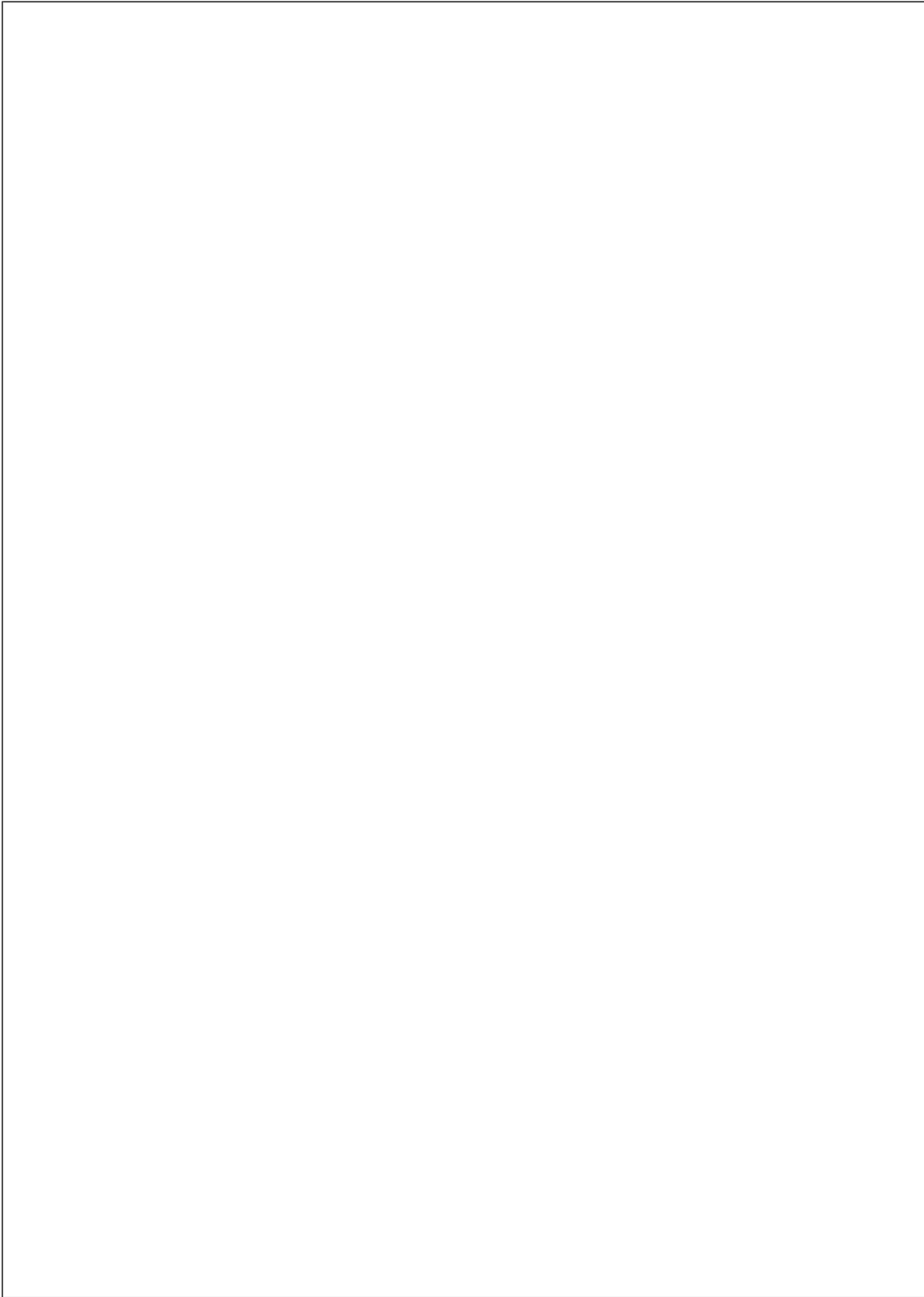

Physical Dimensions inches (millimeters) unless otherwise noted (Continued)

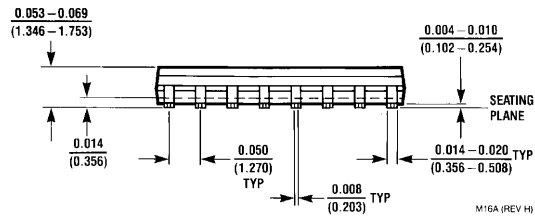
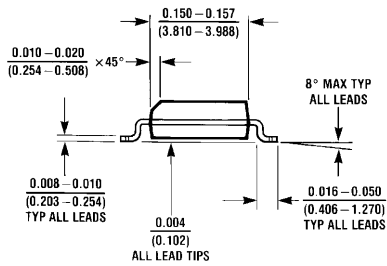
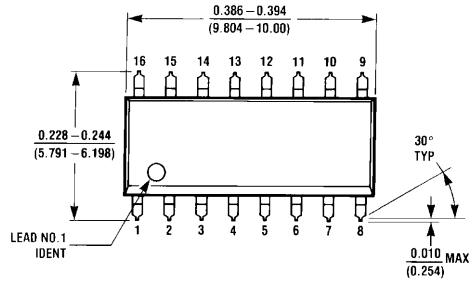

M16A (REV H)

16-Lead Small Outline Molded Package (M)
Order Number DM74LS157M or DM74LS158M
Package Number M16A

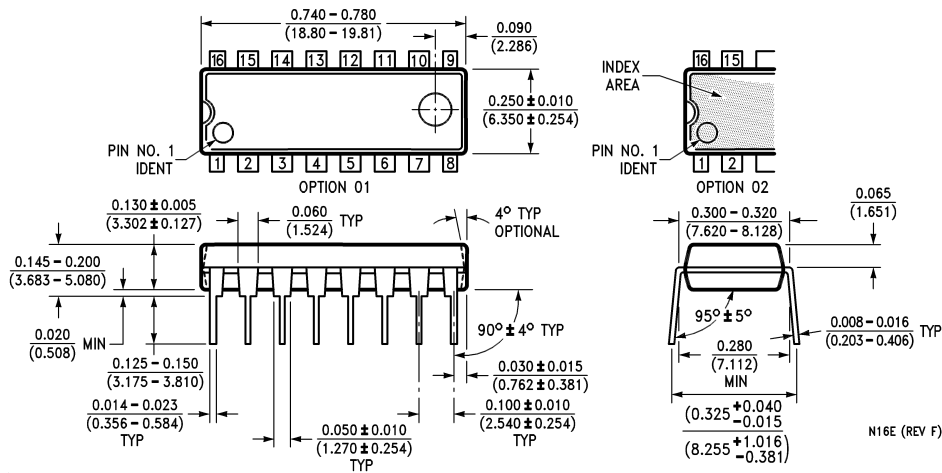

N16E (REV F)

16-Lead Molded Dual-In-Line Package (N)
Order Number DM74LS157N or DM74LS158N
Package Number N16E

Physical Dimensions inches (millimeters) unless otherwise noted (Continued)

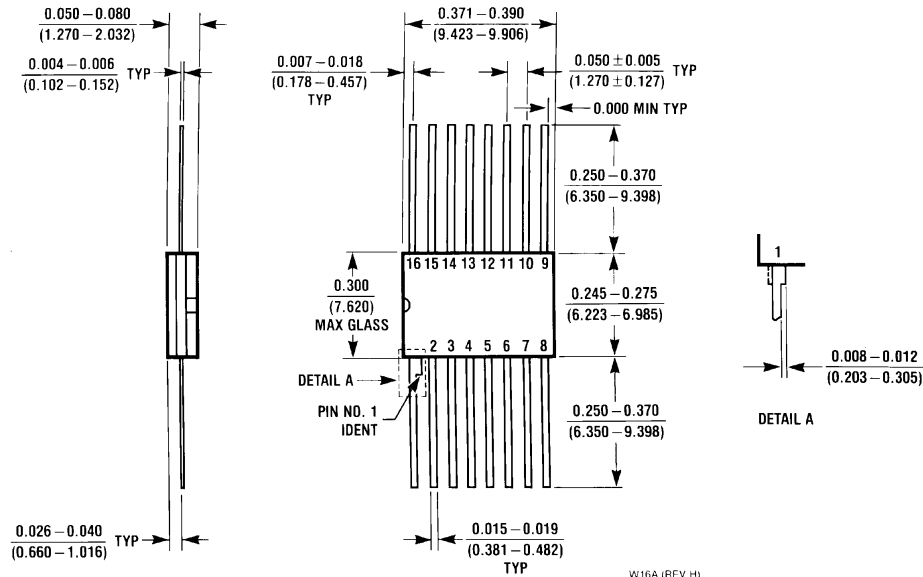

16-Lead Ceramic Flat Package (W)
Order Number 54LS157FMQB, 54LS158FMQB, DM54LS157W or DM54LS158W
Package Number W16A

LIFE SUPPORT POLICY

FAIRCHILD'S PRODUCTS ARE NOT AUTHORIZED FOR USE AS CRITICAL COMPONENTS IN LIFE SUPPORT DEVICES OR SYSTEMS WITHOUT THE EXPRESS WRITTEN APPROVAL OF THE PRESIDENT OF FAIRCHILD SEMICONDUCTOR CORPORATION. As used herein:

- Life support devices or systems are devices or systems which, (a) are intended for surgical implant into the body, or (b) support or sustain life, and (c) whose failure to perform when properly used in accordance with instructions for use provided in the labeling, can be reasonably expected to result in a significant injury to the user.
- A critical component in any component of a life support device or system whose failure to perform can be reasonably expected to cause the failure of the life support device or system, or to affect its safety or effectiveness.

Fairchild Semiconductor Corporation Americas
 Customer Response Center
 Tel: 1-888-522-5372

Fairchild Semiconductor Europe
 Fax: +49 (0) 1 80-530 85 86
 Email: europe.support@nsc.com
 Deutsch Tel: +49 (0) 8 141-35-0
 English Tel: +44 (0) 1 793-85-68-56
 Italy Tel: +39 (0) 2 57 5631

Fairchild Semiconductor Hong Kong Ltd.
 13th Floor, Straight Block,
 Ocean Centre, 5 Canton Rd.
 Tsimshatsui, Kowloon
 Hong Kong
 Tel: +852 2737-7200
 Fax: +852 2314-0061

National Semiconductor Japan Ltd.
 Tel: 81-3-5620-6175
 Fax: 81-3-5620-6179

www.fairchildsemi.com