

DM74LS253 3-STATE Data Selectors/Multiplexers

General Description

Each of these Schottky-clamped data selectors/multiplexers contains inverters and drivers to supply fully complementary, on-chip, binary decoding data selection to the AND-OR gates. Separate output control inputs are provided for each of the two four-line sections.

The 3-STATE outputs can interface directly with data lines of bus-organized systems. With all but one of the common outputs disabled (at a high impedance state), the low impedance of the single enabled output will drive the bus line to a high or low logic level.

Features

- 3-STATE version of LS153 with same pinout

- Schottky-diode-clamped transistors
- Permit multiplexing from N-lines to one line
- Performs parallel-to-serial conversion
- Strobe/output control
- High fanout totem-pole outputs
- Typical propagation delay
Data to output 12 ns
Select to output 21 ns
- Typical power dissipation 35 mW
- Alternate Military/Aerospace device (54LS253) is available. Contact a Fairchild Semiconductor Sales Office/Distributor for specifications.

Connection Diagram

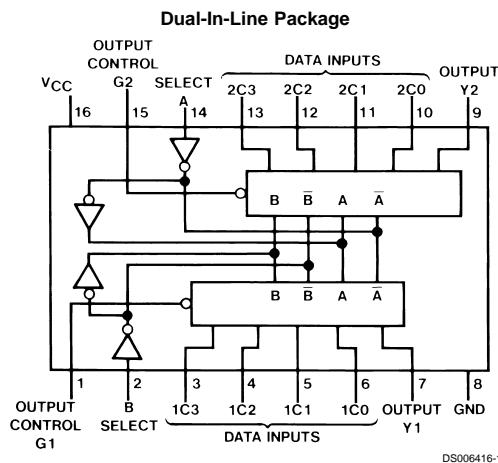

Order Number 54LS253DMQB, 54LS253FMQB,
54LS253LMQB, DM54LS253J, DM54LS253W,
DM74LS253M or DM74LS253N
See Package Number E20A, J16A,
M16A, N16E or W16A

Function Table

Select Inputs		Data Inputs				Output Control	Output
B	A	C0	C1	C2	C3	G	Y
X	X	X	X	X	X	H	Z
L	L	L	X	X	X	L	L
L	L	H	X	X	X	L	H
L	H	X	L	X	X	L	L
L	H	X	H	X	X	L	H
H	L	X	X	L	X	L	L
H	L	X	X	H	X	L	H
H	H	X	X	X	L	L	L
H	H	X	X	X	H	L	H

Address Inputs A and B are common to both sections.
H = High Level, L = Low Level, X = Don't Care, Z = High Impedance (off).

Absolute Maximum Ratings (Note 1)

Supply Voltage	7V	DM54LS and 54LS	-55°C to +125°C
Input Voltage	7V	DM74LS	0°C to +70°C
Operating Free Air Temperature Range		Storage Temperature Range	-65°C to +150°C

Recommended Operating Conditions

Symbol	Parameter	DM54LS253			DM74LS253			Units
		Min	Nom	Max	Min	Nom	Max	
V _{CC}	Supply Voltage	4.5	5	5.5	4.75	5	5.25	V
V _{IH}	High Level Input Voltage	2			2			V
V _{IL}	Low Level Input Voltage			0.7			0.8	V
I _{OH}	High Level Output Current			-1			-2.6	mA
I _{OL}	Low Level Output Current			12			24	mA
T _A	Free Air Operating Temperature	-55		125	0		70	°C

Note 1: The "Absolute Maximum Ratings" are those values beyond which the safety of the device cannot be guaranteed. The device should not be operated at these limits. The parametric values defined in the "Electrical Characteristics" table are not guaranteed at the absolute maximum ratings. The "Recommended Operating Conditions" table will define the conditions for actual device operation.

Electrical Characteristics

over recommended operating free air temperature range (unless otherwise noted)

Symbol	Parameter	Conditions	Min	Typ (Note 2)	Max	Units
V _I	Input Clamp Voltage	V _{CC} = Min, I _I = -18 mA			-1.5	V
V _{OH}	High Level Output Voltage	V _{CC} = Min, I _{OH} = Max	DM54	2.4	3.4	V
		V _{IL} = Max, V _{IH} = Min	DM74	2.4	3.1	
V _{OL}	Low Level Output Voltage	V _{CC} = Min, I _{OL} = Max	DM54		0.4	V
		V _{IL} = Max, V _{IH} = Min	DM74		0.5	
		I _{OL} = 12 mA, V _{CC} = Min	DM74		0.4	
I _I	Input Current @ Max Input Voltage	V _{CC} = Max, V _I = 7V			0.1	mA
I _{IH}	High Level Input Current	V _{CC} = Max, V _I = 2.7V			20	μA
I _{IL}	Low Level Input Current	V _{CC} = Max, V _I = 0.4V			-0.4	mA
I _{OZH}	Off-State Output Current with High Level Output Voltage Applied	V _{CC} = Max, V _O = 2.7V V _{IH} = Min, V _{IL} = Max			20	μA
I _{OZL}	Off-State Output Current with Low Level Output Voltage Applied	V _{CC} = Max, V _O = 0.4 V _{IH} = Min, V _{IL} = Max			-20	μA
I _{OS}	Short Circuit Output Current	V _{CC} = Max	DM54	-20	-100	mA
		(Note 3)	DM74	-20	-100	
I _{CC1}	Supply Current	V _{CC} = Max (Note 4)		7	12	mA
I _{CC2}	Supply Current	V _{CC} = Max (Note 5)		8.5	14	mA

Note 2: All typicals are at V_{CC} = 5V, T_A = 25°C.

Note 3: Not more than one output should be shorted at a time, and the duration should not exceed one second.

Note 4: I_{CC1} is measured with all outputs open, and all the inputs grounded.

Note 5: I_{CC2} is measured with the outputs open, OUTPUT CONTROL at 4.5V and all other inputs grounded.

Switching Characteristics

at $V_{CC} = 5V$ and $T_A = 25^\circ C$

Symbol	Parameter	From (Input) To (Output)	$R_L = 667\Omega$				Units
			$C_L = 45\text{ pF}$		$C_L = 150\text{ pF}$		
			Min	Max	Min	Max	
t_{PLH}	Propagation Delay Time Low to High Level Output	Data to Y		25		35	ns
t_{PHL}	Propagation Delay Time High to Low Level Output	Data to Y		20		30	ns
t_{PLH}	Propagation Delay Time Low to High Level Output	Select to Y		45		54	ns
t_{PHL}	Propagation Delay Time High to Low Level Output	Select to Y		32		44	ns
t_{PZH}	Output Enable Time to High Level Output	Output Control to Y		18		32	ns
t_{PZL}	Output Enable Time to Low Level Output	Output Control to Y		23		35	ns
t_{PHZ}	Output Disable Time from High Level Output (Note 6)	Output Control to Y		41			ns
t_{PLZ}	Output Disable Time from Low Level Output (Note 6)	Output Control to Y		27			ns

Note 6: $C_L = 5\text{ pF}$.

Logic Diagram

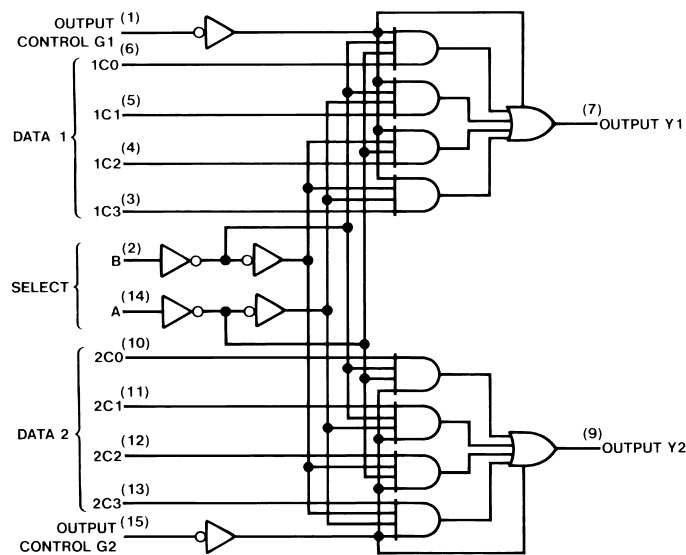

DS006416-2

Physical Dimensions inches (millimeters) unless otherwise noted

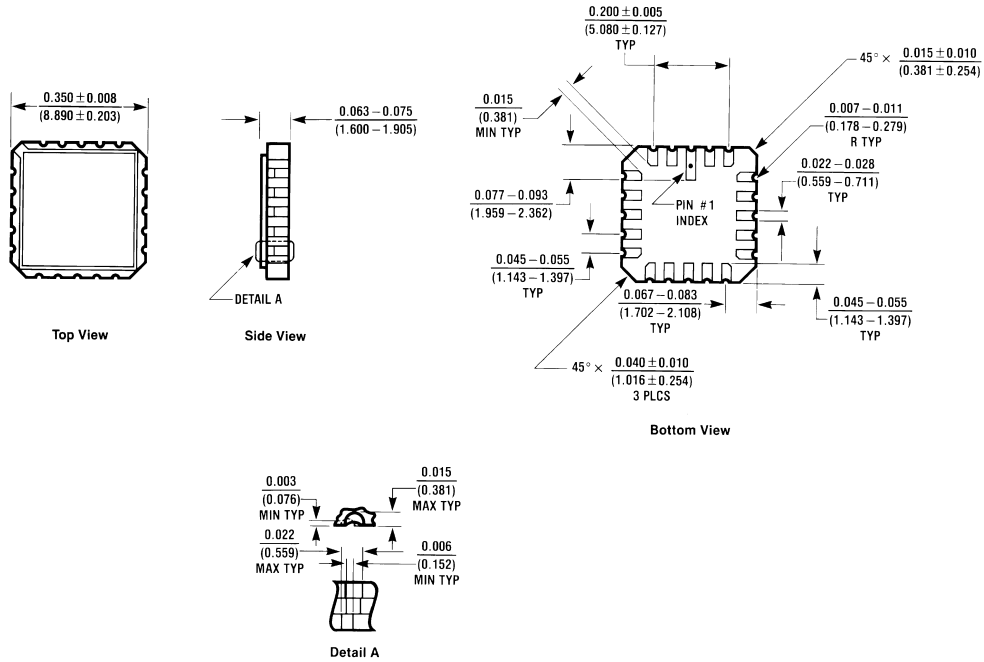

E20A (REV D)

Ceramic Leadless Chip Carrier Package (E)
Order Number 54LS253LMQB
Package Number E20A

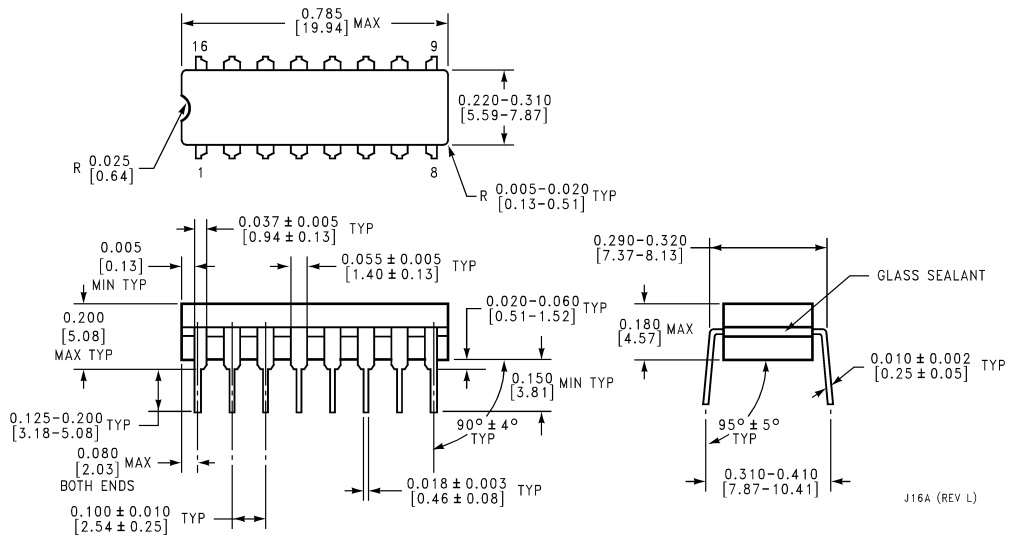

J16A (REV L)

16-Lead Ceramic Dual-In-Line Package (J)
Order Number 54LS253DMQB or DM54LS253J
Package Number J16A

Physical Dimensions inches (millimeters) unless otherwise noted (Continued)

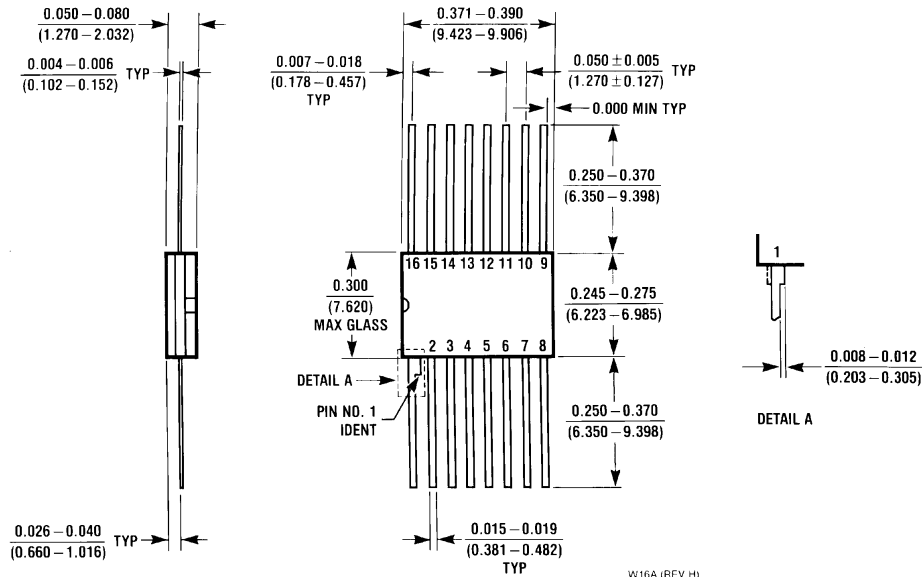

16-Lead Ceramic Flat Package (W)
Order Number 54LS253FMQB or DM54LS253W
Package Number W16A

LIFE SUPPORT POLICY

FAIRCHILD'S PRODUCTS ARE NOT AUTHORIZED FOR USE AS CRITICAL COMPONENTS IN LIFE SUPPORT DEVICES OR SYSTEMS WITHOUT THE EXPRESS WRITTEN APPROVAL OF THE PRESIDENT OF FAIRCHILD SEMICONDUCTOR CORPORATION. As used herein:

1. Life support devices or systems are devices or systems which, (a) are intended for surgical implant into the body, or (b) support or sustain life, and (c) whose failure to perform when properly used in accordance with instructions for use provided in the labeling, can be reasonably expected to result in a significant injury to the user.
2. A critical component in any component of a life support device or system whose failure to perform can be reasonably expected to cause the failure of the life support device or system, or to affect its safety or effectiveness.

Fairchild Semiconductor Corporation Americas
 Customer Response Center
 Tel: 1-888-522-5372

Fairchild Semiconductor Europe
 Fax: +49 (0) 1 80-530 85 86
 Email: europe.support@nsc.com
 Deutsch Tel: +49 (0) 8 141-35-0
 English Tel: +44 (0) 1 793-85-68-56
 Italy Tel: +39 (0) 2 57 5631

Fairchild Semiconductor Hong Kong Ltd.
 13th Floor, Straight Block,
 Ocean Centre, 5 Canton Rd.
 Tsimshatsui, Kowloon
 Hong Kong
 Tel: +852 2737-7200
 Fax: +852 2314-0061

National Semiconductor Japan Ltd.
 Tel: 81-3-5620-6175
 Fax: 81-3-5620-6179

www.fairchildsemi.com