

## DM74LS259 8-Bit Addressable Latches

### General Description

These 8-bit addressable latches are designed for general purpose storage applications in digital systems. Specific uses include working registers, serial-holding registers, and active-high decoders or demultiplexers. They are multifunctional devices capable of storing single-line data in eight addressable latches, and being a 1-of-8 decoder or demultiplexer with active-high outputs.

Four distinct modes of operation are selectable by controlling the clear and enable inputs as enumerated in the function table. In the addressable-latch mode, data at the data-in terminal is written into the addressed latch. The addressed latch will follow the data input with all unaddressed latches remaining in their previous states. In the memory mode, all latches remain in their previous states and are unaffected by the data or address inputs. To eliminate the possibility of entering erroneous data in the latches, the enable should be held high (inactive) while the address lines are changing. In the 1-of-8 decoding or demultiplexing mode, the addressed output will follow the level of the D input with all other outputs low. In the clear mode, all outputs are low and unaffected by the address and data inputs.

### Features

- 8-Bit parallel-out storage register performs serial-to-parallel conversion with storage
- Asynchronous parallel clear
- Active high decoder
- Enable/disable input simplifies expansion
- Direct replacement for Fairchild 9334
- Expandable for N-bit applications
- Four distinct functional modes
- Typical propagation delay times:
  - Enable-to-output 18 ns
  - Data-to-output 16 ns
  - Address-to-output 21 ns
  - Clear-to-output 17 ns
- Fan-out
  - $I_{OL}$  (sink current)
  - 54LS259 4 mA
  - 74LS259 8 mA
  - $I_{OH}$  (source current) -0.4 mA
- Typical  $I_{CC}$  22 mA

### Connection Diagram

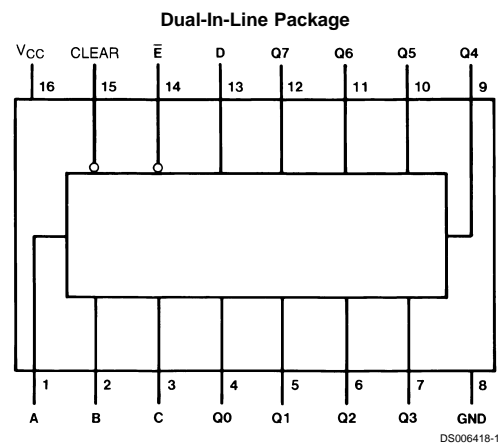

Order Number DM54LS259E, DM54LS259J,  
DM54LS259W, DM74LS259M,  
DM74LS259WM or DM74LS259N  
See Package Number E20A, J16A,  
M16A, M16B, N16E or W16A

DS006418-1

### Function Table

Inputs	Output of Addressed Latch	Each Other Output	Function
Clear $\bar{E}$	D	$Q_{i0}$	Addressable Latch
H	H	$Q_{i0}$	Memory
L	L	L	8-Line Demultiplexer
L	H	L	Clear

### Latch Selection Table

Select Inputs			Latch Addressed
C	B	A	
L	L	L	0
L	L	H	1
L	H	L	2
L	H	H	3
H	L	L	4
H	L	H	5
H	H	L	6
H	H	H	7

H = High Level, L = Low Level  
D = the Level of the Data Input  
 $Q_{i0}$  = the Level of  $Q_i$  ( $i = 0, 1, \dots, 7$ , as Appropriate) before the Indicated Steady-State Input Conditions Were Established.

## Absolute Maximum Ratings (Note 1)

Supply Voltage	7V	DM54	-55°C to +125°C
Input Voltage	7V	DM74LS	0°C to +70°C
Operating Free Air Temperature Range		Storage Temperature Range	-65°C to +150°C

## Recommended Operating Conditions

Symbol	Parameter	DM54LS259			DM74LS259			Units
		Min	Nom	Max	Min	Nom	Max	
V <sub>CC</sub>	Supply Voltage	4.5	5	5.5	4.75	5	5.25	V
V <sub>IH</sub>	High Level Input Voltage	2			2			V
V <sub>IL</sub>	Low Level Input Voltage			0.7			0.8	V
I <sub>OH</sub>	High Level Output Current			-0.4			-0.4	mA
I <sub>OL</sub>	Low Level Output Current			4			8	mA
t <sub>w</sub>	Pulse Width (Note 8)	Enable	17		15			ns
		Clear	17		15			
t <sub>SU</sub>	Setup Time (Notes 2, 3, 4, 8)	Data	20↑		15↑			ns
		Select	15↓		15↓			
t <sub>H</sub>	Hold Time (Notes 2, 3, 8)	Data	5↑		2.5↑			ns
		Select	0↑		2.5↑			
T <sub>A</sub>	Free Air Operating Temperature	-55		125	0		70	°C

**Note 1:** The "Absolute Maximum Ratings" are those values beyond which the safety of the device cannot be guaranteed. The device should not be operated at these limits. The parametric values defined in the "Electrical Characteristics" table are not guaranteed at the absolute maximum ratings. The "Recommended Operating Conditions" table will define the conditions for actual device operation.

## Electrical Characteristics

over recommended operating free air temperature range (unless otherwise noted)

Symbol	Parameter	Conditions	Min	Typ (Note 5)	Max	Units	
V <sub>I</sub>	Input Clamp Voltage	V <sub>CC</sub> = Min, I <sub>I</sub> = -18 mA			-1.5	V	
V <sub>OH</sub>	High Level Output Voltage	V <sub>CC</sub> = Min, I <sub>OH</sub> = Max	DM54	2.5		V	
		V <sub>IL</sub> = Max, V <sub>IH</sub> = Min	DM74	2.7	3.4		
V <sub>OL</sub>	Low Level Output Voltage	V <sub>CC</sub> = Min, I <sub>OL</sub> = Max	DM54		0.4	V	
		V <sub>IL</sub> = Max, V <sub>IH</sub> = Min	DM74	0.35	0.5		
		I <sub>OL</sub> = 4 mA, V <sub>CC</sub> = Min	DM74	0.25	0.4		
I <sub>I</sub>	Input Current @ Max Input Voltage	V <sub>CC</sub> = Max, V <sub>I</sub> = 7V	DM74		0.1	mA	
		V <sub>I</sub> = 10V	DM54				
I <sub>IH</sub>	High Level Input Current	V <sub>CC</sub> = Max, V <sub>I</sub> = 2.7V			20	μA	
I <sub>IL</sub>	Low Level Input Current	V <sub>CC</sub> = Max, V <sub>I</sub> = 0.4V			-0.4	mA	
	Enable	V <sub>CC</sub> = Max, V <sub>I</sub> = 0.4V			-0.8		
I <sub>OS</sub>	Short Circuit Output Current	V <sub>CC</sub> = Max	DM54	-20		-100	mA
		(Note 6)	DM74	-20		-100	
I <sub>CC</sub>	Supply Current	V <sub>CC</sub> = Max (Note 7)		22	36	mA	

**Note 2:** The symbols (↓, ↑) indicate the edge of the clock pulse used for reference: ↑ for rising edge, ↓ for falling edge.

**Note 3:** Setup and hold times are with reference to the enable input.

**Note 4:** The select-to-enable setup time is the time before the High-to-Low enable transition that the select must be stable so that the correct latch is selected and the others not affected.

**Note 5:** All typicals are at V<sub>CC</sub> = 5V, T<sub>A</sub> = 25°C.

**Note 6:** Not more than one output should be shorted at a time, and the duration should not exceed one second.

**Note 7:** I<sub>CC</sub> is measured with all inputs at 4.5V, and all outputs open.

**Note 8:** T<sub>A</sub> = 25°C and V<sub>CC</sub> = 5V.

## Switching Characteristics

at  $V_{CC} = 5V$  and  $T_A = 25^\circ C$

Symbol	Parameter	From (Input) To (Output)	DM54LS		DM74LS		Units
			$C_L = 15 \text{ pF}$		$C_L = 50 \text{ pF}$ $R_L = 2 \text{ k}\Omega$		
			Min	Max	Min	Max	
$t_{PLH}$	Propagation Delay Time Low to High Level Output	Enable to Output		27		38	ns
$t_{PHL}$	Propagation Delay Time High to Low Level Output	Enable to Output		24		32	ns
$t_{PLH}$	Propagation Delay Time Low to High Level Output	Data to Output		30		35	ns
$t_{PHL}$	Propagation Delay Time High to Low Level Output	Data to Output		20		30	ns
$t_{PLH}$	Propagation Delay Time Low to High Level Output	Select to Output		30		41	ns
$t_{PHL}$	Propagation Delay Time High to Low Level Output	Select to Output		29		38	ns
$t_{PHL}$	Propagation Delay Time High to Low Level Output	Clear to Output		18		36	ns





**Physical Dimensions** inches (millimeters) unless otherwise noted (Continued)

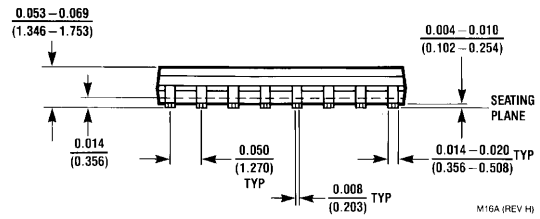
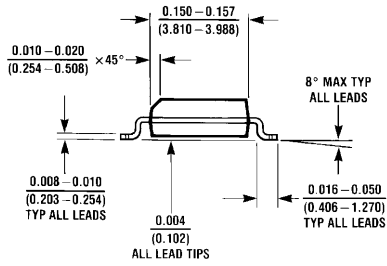
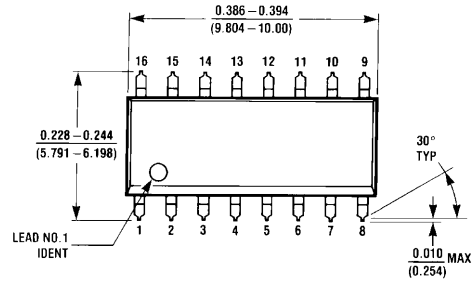

M16A (REV H)

**16-Lead Molded Package Small Outline (SO)**  
**Order Number DM74LS259M**  
**Package Number M16A**

**Physical Dimensions** inches (millimeters) unless otherwise noted (Continued)

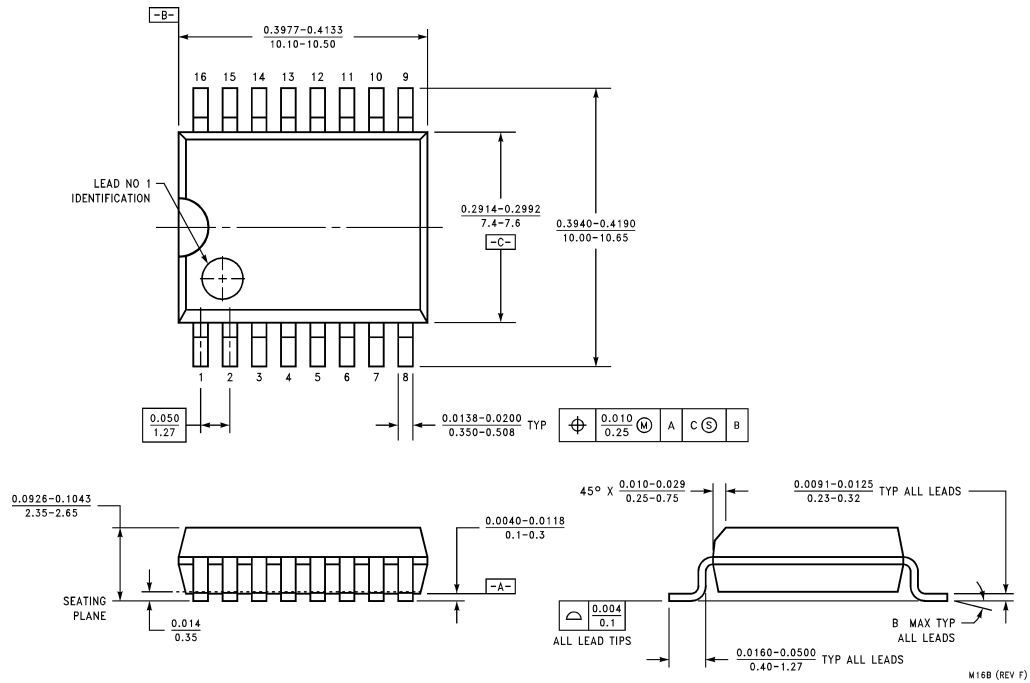

**16-Lead Wide Small Outline Molded Package (M)**  
Order Number DM74LS259WM  
Package Number M16B

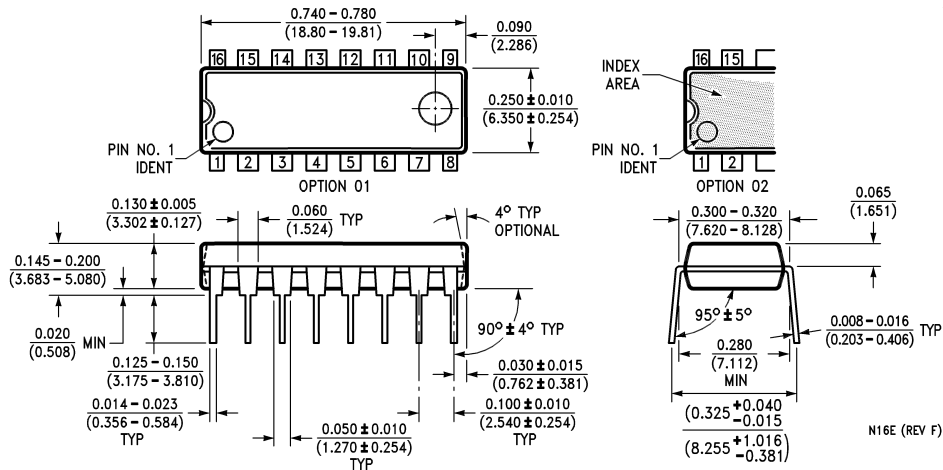

**16-Lead Molded Dual-In-Line Package (N)**  
Order Number DM74LS259N  
Package Number N16E

**DM74LS259 8-Bit Addressable Latches**

**Physical Dimensions** inches (millimeters) unless otherwise noted (Continued)

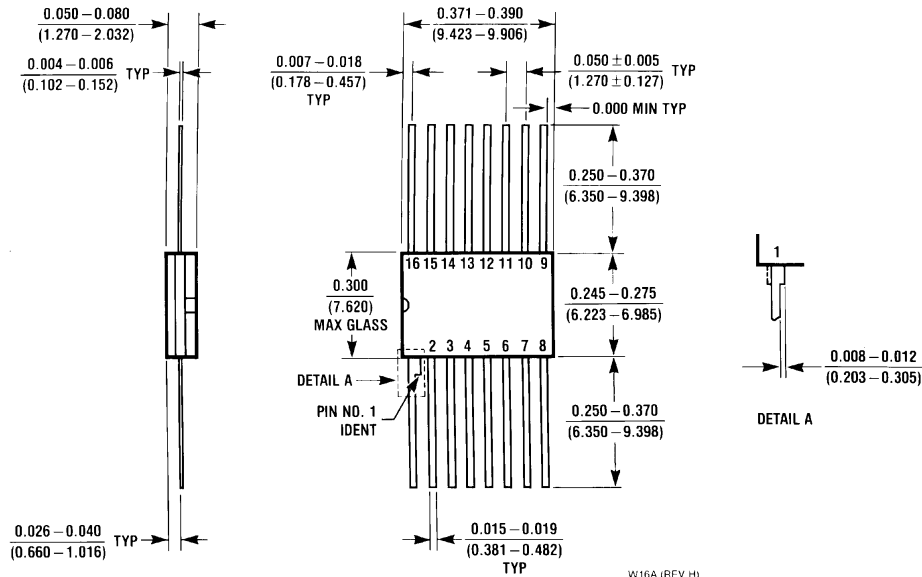

**16-Lead Ceramic Flat Package (W)**  
**Order Number DM54LS259W**  
**Package Number W16A**

**LIFE SUPPORT POLICY**

FAIRCHILD'S PRODUCTS ARE NOT AUTHORIZED FOR USE AS CRITICAL COMPONENTS IN LIFE SUPPORT DEVICES OR SYSTEMS WITHOUT THE EXPRESS WRITTEN APPROVAL OF THE PRESIDENT OF FAIRCHILD SEMICONDUCTOR CORPORATION. As used herein:

1. Life support devices or systems are devices or systems which, (a) are intended for surgical implant into the body, or (b) support or sustain life, and (c) whose failure to perform when properly used in accordance with instructions for use provided in the labeling, can be reasonably expected to result in a significant injury to the user.
2. A critical component in any component of a life support device or system whose failure to perform can be reasonably expected to cause the failure of the life support device or system, or to affect its safety or effectiveness.

**Fairchild Semiconductor Corporation Americas**  
 Customer Response Center  
 Tel: 1-888-522-5372

**Fairchild Semiconductor Europe**  
 Fax: +49 (0) 1 80-530 85 86  
 Email: europe.support@nsc.com  
 Deutsch Tel: +49 (0) 8 141-35-0  
 English Tel: +44 (0) 1 793-85-68-56  
 Italy Tel: +39 (0) 2 57 5631

**Fairchild Semiconductor Hong Kong Ltd.**  
 13th Floor, Straight Block,  
 Ocean Centre, 5 Canton Rd.  
 Tsimshatsui, Kowloon  
 Hong Kong  
 Tel: +852 2737-7200  
 Fax: +852 2314-0061

**National Semiconductor Japan Ltd.**  
 Tel: 81-3-5620-6175  
 Fax: 81-3-5620-6179

[www.fairchildsemi.com](http://www.fairchildsemi.com)

Fairchild does not assume any responsibility for use of any circuitry described, no circuit patent licenses are implied and Fairchild reserves the right at any time without notice to change said circuitry and specifications.