

DM74LS377 Octal D Flip-Flop with Common Enable and Clock

General Description

The 'LS377 is an 8-bit register built using advanced low power Schottky technology. This register consists of eight D-type flip-flops with a buffered common clock and a buffered common input enable. The device is packaged in the space-saving (0.3 inch row spacing) 20-pin package.

Features

- 8-bit high speed parallel registers
- Positive edge-triggered D-type flip-flops
- Fully buffered common clock and enable inputs

Connection Diagram

Dual-In-Line Package

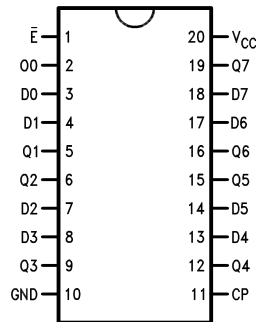

DS009831-1

Order Number DM54LS377E, DM54LS377J,
DM54LS377W, DM74LS377WM or DM74LS377N
See Package Number
E20A, J20A, M20B, N20A or W20A

Pin Names	Description
\bar{E}	Enable Input (Active LOW)
D0–D7	Data Inputs
CP	Clock Pulse Input (Active Rising Edge)
Q0–Q7	Flip-Flop Outputs

Absolute Maximum Ratings (Note 1)

Supply Voltage	7V	DM54LS	-55°C to +125°C
Input Voltage	7V	DM74LS	0°C to +70°C
Operating Free Air Temperature Range		Storage Temperature Range	-65°C to +150°C

Recommended Operating Conditions

Symbol	Parameter	DM54LS377			DM74LS377			Units
		Min	Nom	Max	Min	Nom	Max	
V _{CC}	Supply Voltage	4.5	5	5.5	4.75	5	5.25	V
V _{IH}	High Level Input Voltage	2			2			V
V _{IL}	Low Level Input Voltage			0.7			0.8	V
I _{OH}	High Level Output Current			-0.4			-0.4	mA
I _{OL}	Low Level Output Current			4			8	mA
T _A	Free Air Operating Temperature	-55		125	0		70	°C
t _s (H)	Setup Time HIGH or LOW	20			10			ns
t _s (L)	D _n to CP	20			10			ns
t _h (H)	Hold Time HIGH or LOW	5.0			5.0			ns
t _h (L)	D _n to CP	5.0			5.0			ns
t _s (H)	Setup Time HIGH or LOW	10			10			ns
t _s (L)	\bar{E} to CP	20			20			ns
t _h (H)	Hold Time HIGH or LOW	5.0			5.0			ns
t _h (L)	\bar{E} to CP	5.0			5.0			ns
t _w (H)	CP Pulse Width HIGH or LOW	20			20			ns
t _w (L)		20			20			ns

Note 1: The "Absolute Maximum Ratings" are those values beyond which the safety of the device cannot be guaranteed. The device should not be operated at these limits. The parametric values defined in the "Electrical Characteristics" table are not guaranteed at the absolute maximum ratings. The "Recommended Operating Conditions" table will define the conditions for actual device operation.

Electrical Characteristics

over recommended operating free air temperature range (unless otherwise noted)

Symbol	Parameter	Conditions	Min	Typ (Note 2)	Max	Units
V _I	Input Clamp Voltage	V _{CC} = Min, I _I = -18 mA			-1.5	V
V _{OH}	High Level Output Voltage	V _{CC} = Min, I _{OH} = Max	DM54	2.5		V
		V _{IL} = Max	DM74	2.7	3.4	
V _{OL}	Low Level Output Voltage	V _{CC} = Min, I _{OL} = Max	DM54		0.4	V
		V _{IH} = Min	DM74		0.35	
		I _{OL} = 4 mA, V _{CC} = Min	DM74		0.25	
I _I	Input Current @ Max Input Voltage	V _{CC} = Max, V _I = 7V	DM74		0.1	mA
		V _I = 10V	DM54			
I _{IH}	High Level Input Current	V _{CC} = Max, V _I = 2.7V			20.0	μA
I _{IL}	Low Level Input Current	V _{CC} = Max, V _I = 0.4V			-0.4	mA
I _{OS}	Short Circuit Output Current	V _{CC} = Max	DM54	-20	-100	mA
		(Note 3)	DM74	-20	-100	
I _{CC}	Supply Current	V _{CC} = Max			28	mA

Note 2: All typicals are at V_{CC} = 5V, T_A = 25°C.

Note 3: Not more than one output should be shorted at a time, and the duration should not exceed one second.

Switching Characteristics

$V_{CC} = +5.0V$, $T_A = +25^\circ C$

Symbol	Parameter	$R_L = 2\text{ k}\Omega$, $C_L = 15\text{ pF}$		Units
		Min	Max	
f_{max}	Maximum Clock Frequency	30		MHz
t_{PLH}	Propagation Delay		25	ns
t_{PHL}	CP to Q_n		25	

Functional Description

The 'LS377 consists of eight edge-triggered D flip-flops with individual D inputs and Q outputs. The Clock (CP) and Enable input (\bar{E}) are common to all flip-flops.

When \bar{E} is LOW, new data is entered into the register on the next LOW-to-HIGH transition of CP. When \bar{E} is HIGH, the register will retain the present data independent of the CP.

Truth Table

Inputs			Output
\bar{E}	CP	D_n	Q_n
H	X	X	No Change
L	\nearrow	H	H
L	\nearrow	L	L

H = HIGH Voltage Level
L = LOW Voltage Level
X = Immaterial

Logic Symbol

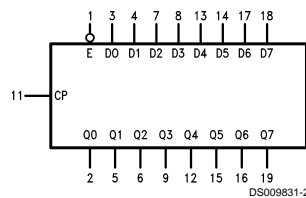

$V_{CC} = \text{Pin } 20$
 $GND = \text{Pin } 10$

Logic Diagram

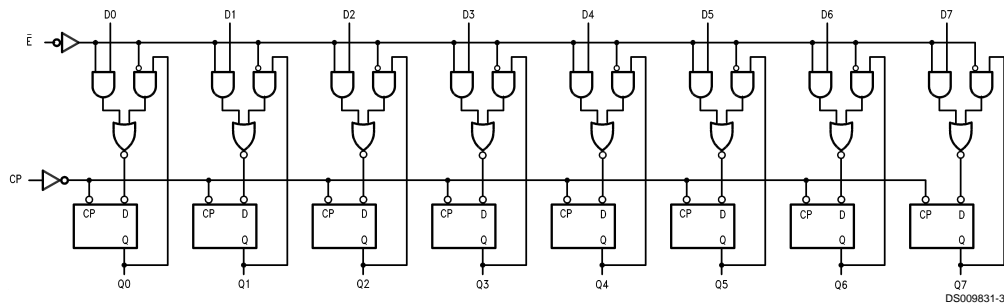



Physical Dimensions inches (millimeters) unless otherwise noted

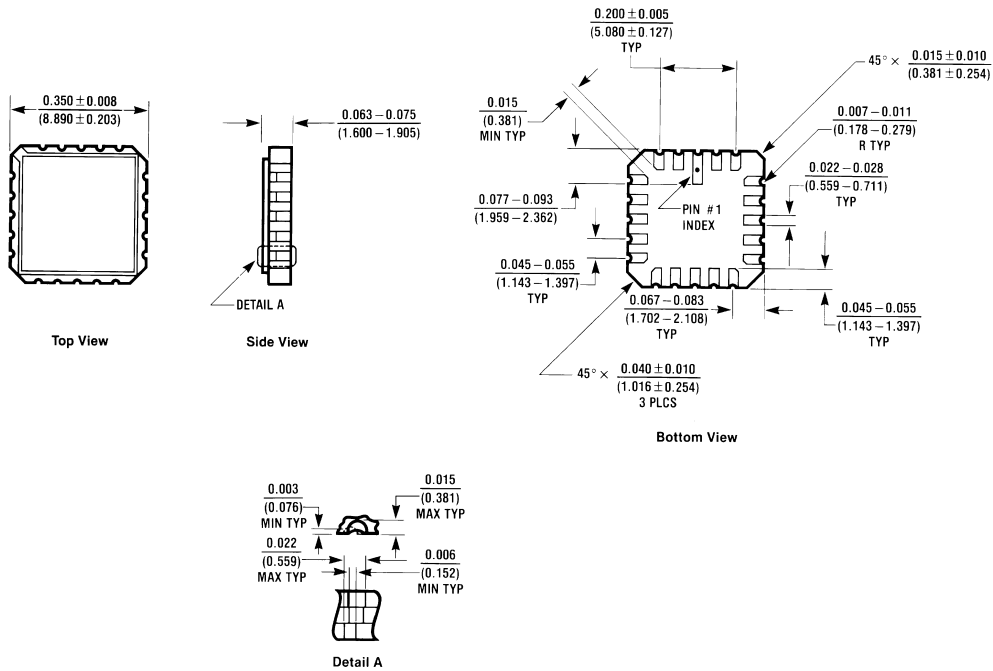

Ceramic Leadless Chip Carrier (E)
Order Number DM54LS377E
Package Number E20A

E20A (REV D)

Physical Dimensions inches (millimeters) unless otherwise noted (Continued)

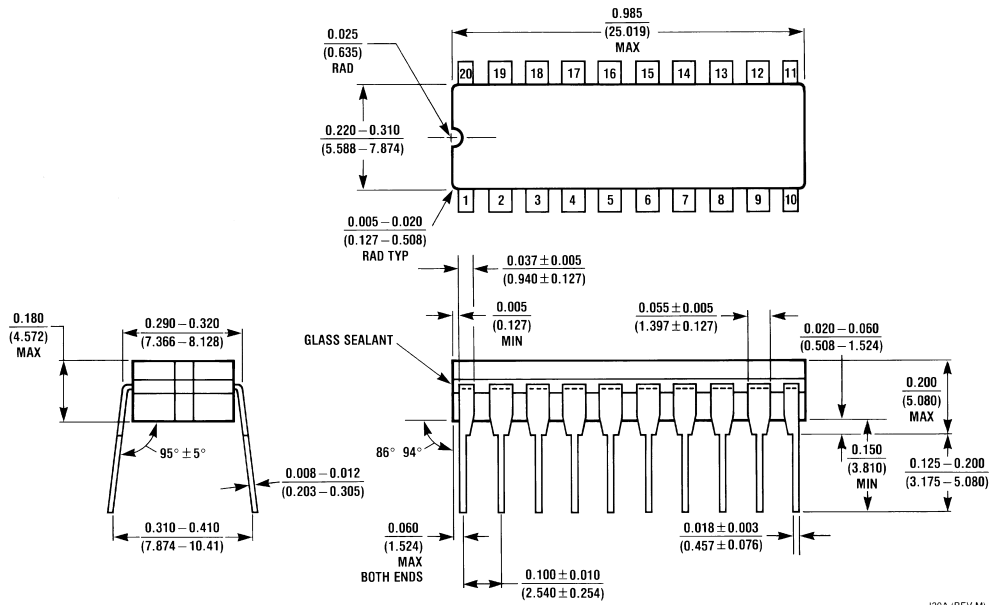

20-Lead Ceramic Dual-In-Line Package (J)
Order Number DM54LS377J
Package Number J20A

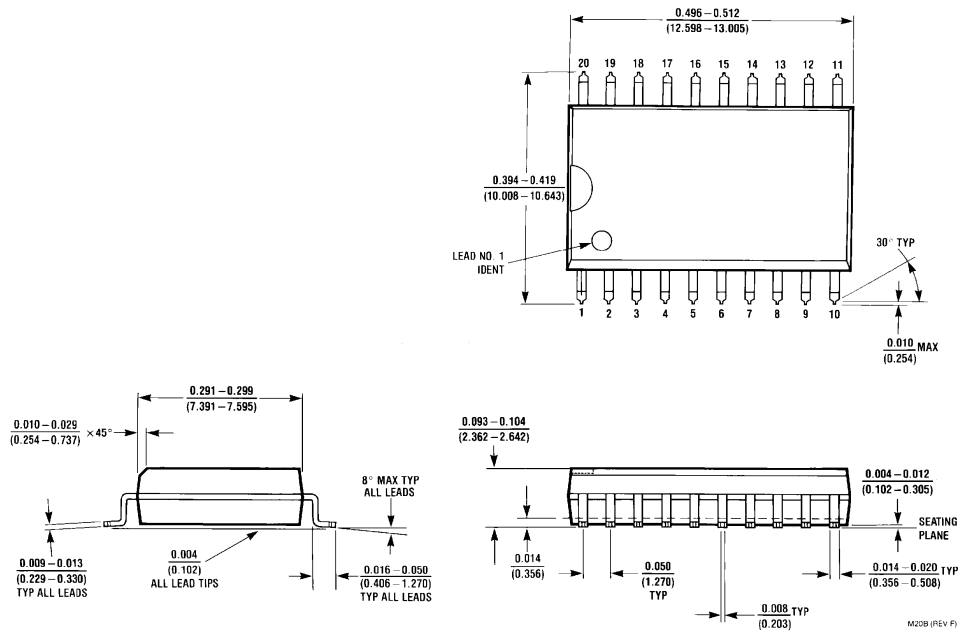

20-Lead Wide Small Outline Molded Package (M)
Order Number DM74LS377WM
Package Number M20B

Physical Dimensions inches (millimeters) unless otherwise noted (Continued)

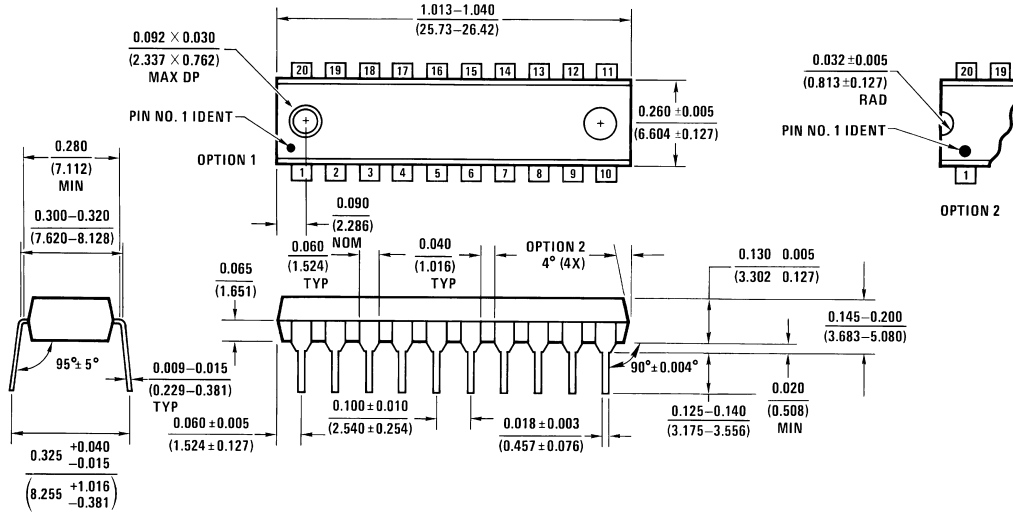

N20A (REV G)

20-Lead Molded Dual-In-Line Package (N)
Order Number DM74LS377N
Package Number N20A

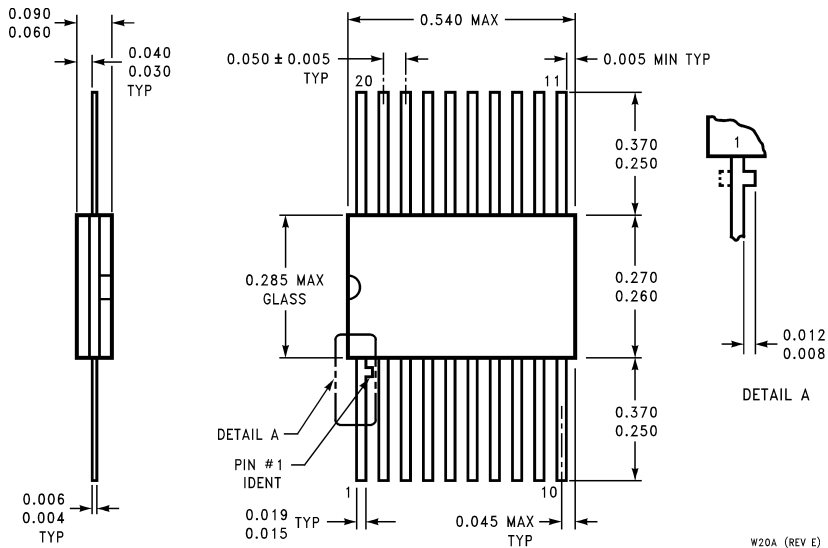

W20A (REV E)

20-Lead Ceramic Flat Package (W)
Order Number DM54LS377W
Package Number W20A

LIFE SUPPORT POLICY

FAIRCHILD'S PRODUCTS ARE NOT AUTHORIZED FOR USE AS CRITICAL COMPONENTS IN LIFE SUPPORT DEVICES OR SYSTEMS WITHOUT THE EXPRESS WRITTEN APPROVAL OF THE PRESIDENT OF FAIRCHILD SEMICONDUCTOR CORPORATION. As used herein:

1. Life support devices or systems are devices or systems which, (a) are intended for surgical implant into the body, or (b) support or sustain life, and (c) whose failure to perform when properly used in accordance with instructions for use provided in the labeling, can be reasonably expected to result in a significant injury to the user.
2. A critical component in any component of a life support device or system whose failure to perform can be reasonably expected to cause the failure of the life support device or system, or to affect its safety or effectiveness.

Fairchild Semiconductor Corporation Americas
Customer Response Center
Tel: 1-888-522-5372

Fairchild Semiconductor Europe
Fax: +49 (0) 1 80-530 85 86
Email: europe.support@nsc.com
Deutsch Tel: +49 (0) 8 141-35-0
English Tel: +44 (0) 1 793-85-68-56
Italy Tel: +39 (0) 2 57 5631

Fairchild Semiconductor Hong Kong Ltd.
13th Floor, Straight Block,
Ocean Centre, 5 Canton Rd.
Tsimshatsui, Kowloon
Hong Kong
Tel: +852 2737-7200
Fax: +852 2314-0061

National Semiconductor Japan Ltd.
Tel: 81-3-5620-6175
Fax: 81-3-5620-6179

www.fairchildsemi.com