

## DM74LS645 Octal Bus Transceivers

### General Description

These octal bus transceivers are designed for asynchronous two-way communication between data buses. The devices transmit data from the A bus to the B bus or from the B bus to the A bus depending upon the level at the direction control (DIR) input. The enable input ( $\bar{G}$ ) can be used to disable the device so that the buses are effectively isolated.

### Features

- Bi-directional bus transceivers in high-density 20-pin packages
- Hysteresis at bus inputs improves noise margins
- 3-STATE outputs

### Connection Diagram

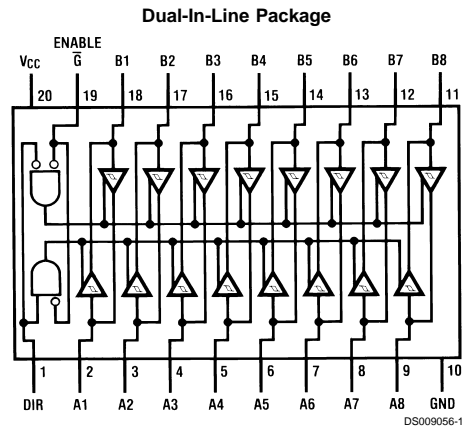

Order Number DM74LS645WM or DM74LS645N  
See Package Number M20B or N20A

### Function Table

Control Inputs		'LS645
$\bar{G}$	DIR	
L	L	B data to A bus
L	H	A data to B bus
H	X	Isolation

H = High Level  
L = Low Level  
X = Irrelevant

**Absolute Maximum Ratings** (Note 1)Supply Voltage  
Input Voltage7V  
7V

Operating Free Air Temperature Range

DM74LS

0°C to +70°C

Storage Temperature Range

-55°C to +150°C

**Recommended Operating Conditions**

Symbol	Parameter	DM74LS645			Units
		Min	Nom	Max	
V <sub>CC</sub>	Supply Voltage (Note 2)	4.75	5	5.25	V
V <sub>IH</sub>	High Level Input Voltage	2			V
V <sub>IL</sub>	Low Level Input Voltage			0.6	V
I <sub>OH</sub>	High Level Output Current			-15	mA
I <sub>OL</sub>	Low Level Output Current			24	mA
T <sub>A</sub>	Free Air Operating Temperature	0		70	°C

**Note 1:** The "Absolute Maximum Ratings" are those values beyond which the safety of the device cannot be guaranteed. The device should not be operated at these limits. The parametric values defined in the "Electrical Characteristics" table are not guaranteed at the absolute maximum ratings. The "Recommended Operating Conditions" table will define the conditions for actual device operation.

**Electrical Characteristics**

over recommended operating free air temperature range (unless otherwise noted)

Symbol	Parameter	Conditions (Note 3)	Min	Typ (Note 4)	Max	Units
V <sub>I</sub>	Input Clamp Voltage	V <sub>CC</sub> = Min, I <sub>I</sub> = 18 mA			-1.5	V
H <sub>YS</sub>	Hysteresis (V <sub>T+</sub> - V <sub>T-</sub> ) A or B Input	V <sub>CC</sub> = Min	0.2	0.4		V
V <sub>OH</sub>	High Level Output Voltage	V <sub>CC</sub> = Min, V <sub>IH</sub> = 2V, V <sub>IL</sub> = Max	I <sub>OH</sub> = -3 mA 2	3.4		V
V <sub>OL</sub>	Low Level Output Voltage	V <sub>CC</sub> = Min, V <sub>IH</sub> = 2V, V <sub>IL</sub> = Max	I <sub>OL</sub> = 12 mA I <sub>OL</sub> = 24 mA	0.25 0.35	0.4 0.5	V
I <sub>OZH</sub>	Off-State Output Current, High Level Voltage Applied	V <sub>CC</sub> = Max, G at 2V, V <sub>O</sub> = 2.7V			20	μA
I <sub>OZL</sub>	Off-State Output Current, Low Level Voltage Applied	V <sub>CC</sub> = Max, G at 2V V <sub>O</sub> = 0.4V			-400	μA
I <sub>I</sub>	Input Current at Maximum Input Voltage	V <sub>CC</sub> = Max	A or B DIR or G	V <sub>I</sub> = 5.5V V <sub>I</sub> = 7V	0.1 0.1	mA
I <sub>IH</sub>	High Level Input Current	V <sub>CC</sub> = Max, V <sub>IH</sub> = 2.7			20	μA
I <sub>IL</sub>	Low Level Input Current	V <sub>CC</sub> = Max, V <sub>IL</sub> = 0.4V			-0.4	mA
I <sub>OS</sub>	Short Circuit Output Current (Note 5)	V <sub>CC</sub> = Max	-40		-225	mA
I <sub>CC</sub>	Total Supply Current	Outputs High Outputs Low Outputs at Hi-Z	V <sub>CC</sub> = Max, Outputs Open	48 62 64	70 90 95	mA

**Note 2:** Voltage values are with respect to the network ground terminal.

**Note 3:** For conditions shown as Min or Max, use the appropriate value specified under Recommended Operating Conditions.

**Note 4:** All typicals are at V<sub>CC</sub> = 5V, T<sub>A</sub> = 25°C.

**Note 5:** Not more than one output should be shorted at a time, and the duration should not exceed one second.

## Switching Characteristics

at  $V_{CC} = 5V$  and  $T_A = 25^\circ C$

Symbol	Parameter	From (Input) To (Output)	$R_L = 667\Omega$				Units
			$C_L = 45\text{ pF}$		$C_L = 5\text{ pF}$		
			Min	Max	Min	Max	
$t_{PLH}$	Propagation Delay Time Low to High Level Output	A to B		15			ns
$t_{PHL}$	Propagation Delay Time High to Low Level Output	A to B		15			ns
$t_{PLH}$	Propagation Delay Time Low to High Level Output	B to A		15			ns
$t_{PHL}$	Propagation Delay Time High to Low Level Output	B to A		15			ns
$t_{PZL}$	Output Enable Time to Low Level	$\overline{G}$ to A		40			ns
$t_{PZH}$	Output Enable Time to High Level	$\overline{G}$ to A		40			ns
$t_{PZL}$	Output Enable Time to Low Level	$\overline{G}$ to B		40			ns
$t_{PZH}$	Output Enable Time to High Level	$\overline{G}$ to B		40			ns
$t_{PLZ}$	Output Disable Time to Low Level	$\overline{G}$ to A				25	ns
$t_{PHZ}$	Output Disable Time to High Level	$\overline{G}$ to A				25	ns
$t_{PLZ}$	Output Disable Time to Low Level	$\overline{G}$ to B				25	ns
$t_{PHZ}$	Output Disable Time to High Level	$\overline{G}$ to B				25	ns



**Physical Dimensions** inches (millimeters) unless otherwise noted

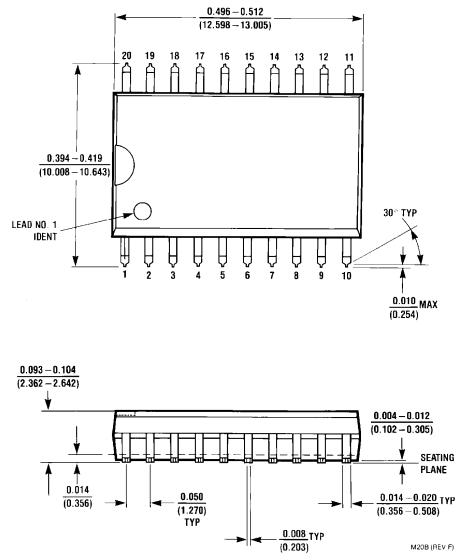

**20-Lead Wide Small Outline Molded Package (M)**  
**Order Number DM74LS645WM**  
**Package Number M20B**

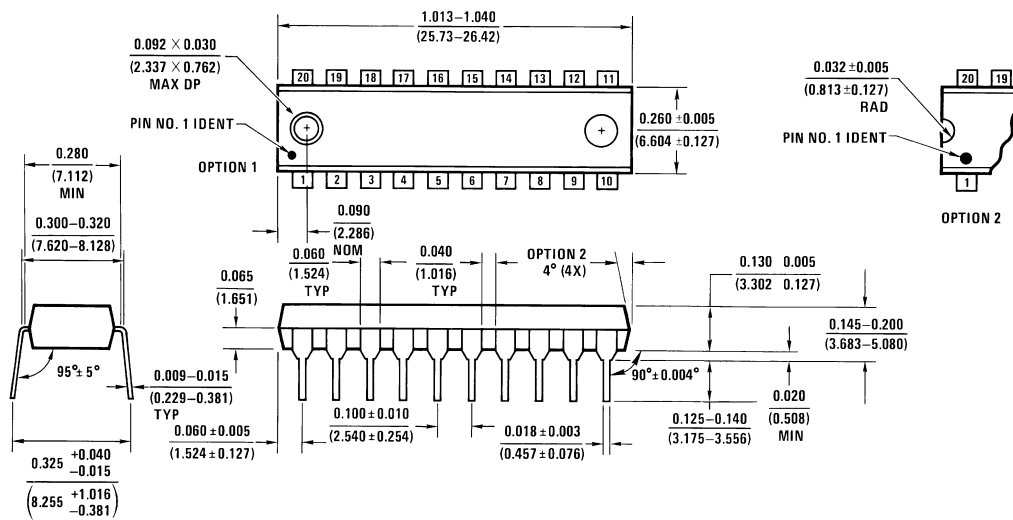

**20-Lead Molded Dual-In-Line Package (N)**  
**Order Number DM74LS645N**  
**Package Number N20A**

**LIFE SUPPORT POLICY**

FAIRCHILD'S PRODUCTS ARE NOT AUTHORIZED FOR USE AS CRITICAL COMPONENTS IN LIFE SUPPORT DEVICES OR SYSTEMS WITHOUT THE EXPRESS WRITTEN APPROVAL OF THE PRESIDENT OF FAIRCHILD SEMICONDUCTOR CORPORATION. As used herein:

1. Life support devices or systems are devices or systems which, (a) are intended for surgical implant into the body, or (b) support or sustain life, and (c) whose failure to perform when properly used in accordance with instructions for use provided in the labeling, can be reasonably expected to result in a significant injury to the user.
2. A critical component in any component of a life support device or system whose failure to perform can be reasonably expected to cause the failure of the life support device or system, or to affect its safety or effectiveness.

**Fairchild Semiconductor Corporation Americas**  
Customer Response Center  
Tel: 1-888-522-5372

**Fairchild Semiconductor Europe**  
Fax: +49 (0) 1 80-530 85 86  
Email: europe.support@nsc.com  
Deutsch Tel: +49 (0) 8 141-35-0  
English Tel: +44 (0) 1 793-85-68-56  
Italy Tel: +39 (0) 2 57 5631

**Fairchild Semiconductor Hong Kong Ltd.**  
13th Floor, Straight Block,  
Ocean Centre, 5 Canton Rd.  
Tsimshatsui, Kowloon  
Hong Kong  
Tel: +852 2737-7200  
Fax: +852 2314-0061

**National Semiconductor Japan Ltd.**  
Tel: 81-3-5620-6175  
Fax: 81-3-5620-6179

[www.fairchildsemi.com](http://www.fairchildsemi.com)