

DM74S140 Dual 4-Input NAND 50Ω Line Driver

General Description

This device contains two independent line driver gates each of which performs the logic NAND function.

Connection Diagram

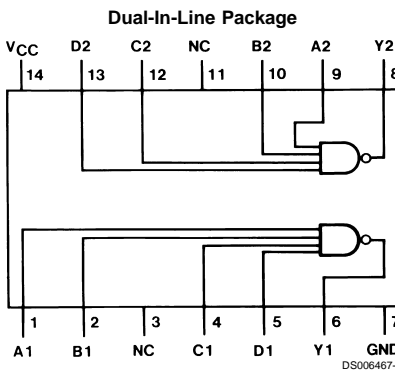

Function Table

$$Y = \overline{ABCD}$$

Inputs				Output
A	B	C	D	Y
X	X	X	L	H
X	X	L	X	H
X	L	X	X	H
L	X	X	X	H
H	H	H	H	L

H = High Logic Level
L = Low Logic Level
X = Either Low or High Logic Level

Absolute Maximum Ratings (Note 1)

Supply Voltage	7V	DM54S	-55°C to +125°C
Input Voltage	5.5V	DM74S	0°C to +70°C
Operating Free Air Temperature Range		Storage Temperature Range	-65°C to +150°C

Recommended Operating Conditions

Symbol	Parameter	DM54S140			DM74S140			Units
		Min	Nom	Max	Min	Nom	Max	
V _{CC}	Supply Voltage	4.5	5	5.5	4.75	5	5.25	V
V _{IH}	High Level Input Voltage	2			2			V
V _{IL}	Low Level Input Voltage			0.8			0.8	V
I _{OH}	High Level Output Current			-3			-3	mA
I _{OL}	Low Level Output Current			60			60	mA
T _A	Free Air Operating Temperature	-55		125	0		70	°C

Note 1: The "Absolute Maximum Ratings" are those values beyond which the safety of the device cannot be guaranteed. The device should not be operated at these limits. The parametric values defined in the "Electrical Characteristics" table are not guaranteed at the absolute maximum ratings. The "Recommended Operating Conditions" table will define the conditions for actual device operation.

Electrical Characteristics

over recommended operating free air temperature (unless otherwise noted)

Symbol	Parameter	Conditions	Min	Typ (Note 2)	Max	Units
V _I	Input Clamp Voltage	V _{CC} = Min, I _I = -18 mA			-1.2	V
V _{OH}	High Level Output Voltage	V _{CC} = Min, V _{IL} = Max	DM54	2.5	3.4	V
		I _{OH} = Max	DM74	2.7	3.4	
		V _{IL} = 0.5V, R _O = 50Ω to GND		2.0		
V _{OL}	Low Level Output Voltage	V _{CC} = Min, I _{OL} = Max V _{IH} = Min			0.5	V
I _I	Input Current @ Max Input Voltage	V _{CC} = Max, V _I = 5.5V			1	mA
I _{IH}	High Level Input Current	V _{CC} = Max, V _I = 2.7V			100	μA
I _{IL}	Low Level Input Current	V _{CC} = Max, V _I = 0.5V			-4	mA
I _{OS}	Short Circuit Output Current	V _{CC} = Max	DM54	-50	-225	mA
		(Note 3)	DM74	-50	-225	
I _{CCH}	Supply Current with Outputs High	V _{CC} = Max		10	18	mA
I _{CCL}	Supply Current with Outputs Low	V _{CC} = Max		25	44	mA

Switching Characteristics

at V_{CC} = 5V and T_A = 25°C

Symbol	Parameter	R _L = 93Ω				Units
		C _L = 50 pF		C _L = 150 pF		
		Min	Max	Min	Max	
t _{PLH}	Propagation Delay Time Low to High Level Output	2	6.5	3	9	ns
t _{PHL}	Propagation Delay Time High to Low Level Output	2	6.5	3	9	ns

Note 2: All typicals are at V_{CC} = 5V, T_A = 25°C.

Note 3: Not more than one output should be shorted at a time, and the duration should not exceed one second.

Physical Dimensions inches (millimeters) unless otherwise noted

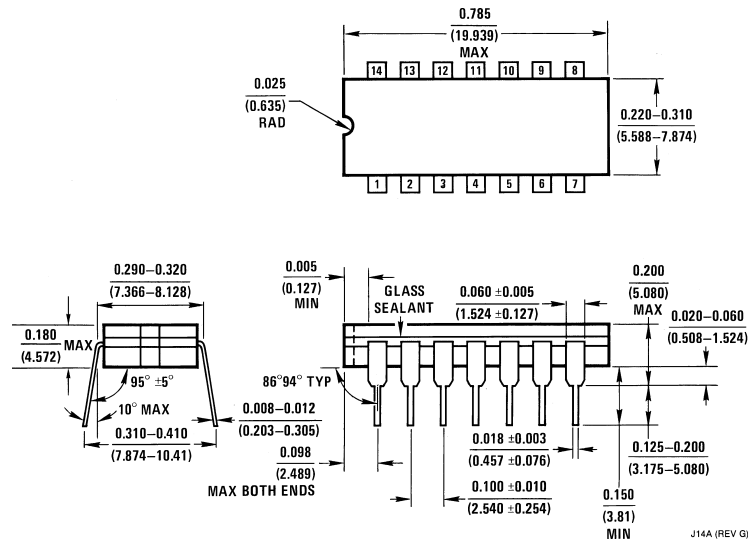

14-Lead Ceramic Dual-In-Line Package (J)
Order Number DM54S140J
Package Number J14A

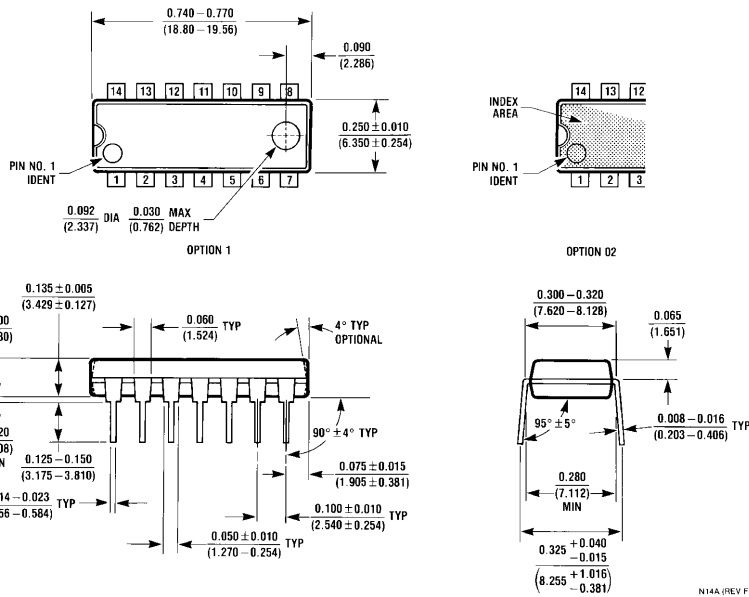

14-Lead Molded Dual-In-Line Package (N)
Order Number DM74S140N
Package Number N14A

LIFE SUPPORT POLICY

FAIRCHILD'S PRODUCTS ARE NOT AUTHORIZED FOR USE AS CRITICAL COMPONENTS IN LIFE SUPPORT DEVICES OR SYSTEMS WITHOUT THE EXPRESS WRITTEN APPROVAL OF THE PRESIDENT OF FAIRCHILD SEMICONDUCTOR CORPORATION. As used herein:

1. Life support devices or systems are devices or systems which, (a) are intended for surgical implant into the body, or (b) support or sustain life, and (c) whose failure to perform when properly used in accordance with instructions for use provided in the labeling, can be reasonably expected to result in a significant injury to the user.
2. A critical component in any component of a life support device or system whose failure to perform can be reasonably expected to cause the failure of the life support device or system, or to affect its safety or effectiveness.

Fairchild Semiconductor Corporation Americas
Customer Response Center
Tel: 1-888-522-5372

Fairchild Semiconductor Europe
Fax: +49 (0) 1 80-530 85 86
Email: europe.support@nsc.com
Deutsch Tel: +49 (0) 8 141-35-0
English Tel: +44 (0) 1 793-85-68-56
Italy Tel: +39 (0) 2 57 5631

Fairchild Semiconductor Hong Kong Ltd.
13th Floor, Straight Block,
Ocean Centre, 5 Canton Rd.
Tsimshatsui, Kowloon
Hong Kong
Tel: +852 2737-7200
Fax: +852 2314-0061

National Semiconductor Japan Ltd.
Tel: 81-3-5620-6175
Fax: 81-3-5620-6179

www.fairchildsemi.com