

DM74S151

1-of-8 Data Selector/Multiplexer with Complementary Outputs

General Description

These data selectors/multiplexers contain full on-chip decoding to select the desired data source. The 'S151 selects one-of-eight data sources. The 'S151 has a strobe input which must be at a low logic level to enable these devices. A high level at the strobe forces the W output high and the Y output low.

The 'S151 features complementary W and Y outputs.

- Performs parallel-to-serial conversion
- Permits multiplexing from N lines to one line
- Also for use as Boolean function generator
- Typical average propagation delay time, data input to W output 4.5 ns
- Typical power dissipation 225 mW

Features

- Select one-of-eight data lines

Connection Diagram

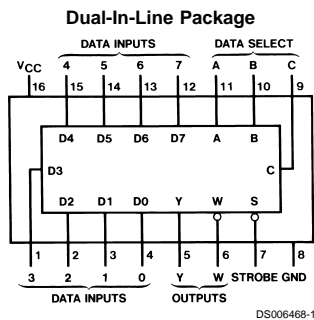

Order Number DM54S151J, DM54S151W or DM74S151N
See Package Number J16A, N16E or W16A

Function Table

Inputs				Outputs	
Select			Strobe S	Y	W
C	B	A			
X	X	X	H	L	H
L	L	L	L	D0	$\overline{D0}$
L	L	H	L	D1	$\overline{D1}$
L	H	L	L	D2	$\overline{D2}$
L	H	H	L	D3	$\overline{D3}$
H	L	L	L	D4	$\overline{D4}$
H	L	H	L	D5	$\overline{D5}$
H	H	L	L	D6	$\overline{D6}$
H	H	H	L	D7	$\overline{D7}$

H = high level, L = low level, X = don't care
D0, D1...D7 = the level of the respective D input

Absolute Maximum Ratings (Note 1)

Supply Voltage	7V	DM54S	-55°C to +125°C
Input Voltage	5.5V	DM74S	0°C to +70°C
Operating Free Air Temperature Range		Storage Temperature Range	-65°C to +150°C

Recommended Operating Conditions

Symbol	Parameter	DM54S151			DM74S151			Units
		Min	Nom	Max	Min	Nom	Max	
V _{CC}	Supply Voltage	4.5	5	5.5	4.75	5	5.25	V
V _{IH}	High Level Input Voltage	2			2			V
V _{IL}	Low Level Input Voltage			0.8			0.8	V
I _{OH}	High Level Output Current			-1			-1	mA
I _{OL}	Low Level Output Current			20			20	mA
T _A	Free Air Operating Temperature	-55		125	0		70	°C

Note 1: The "Absolute Maximum Ratings" are those values beyond which the safety of the device cannot be guaranteed. The device should not be operated at these limits. The parametric values defined in the "Electrical Characteristics" table are not guaranteed at the absolute maximum ratings. The "Recommended Operating Conditions" table will define the conditions for actual device operation.

Electrical Characteristics

over recommended operating free air temperature (unless otherwise noted)

Symbol	Parameter	Conditions	Min	Typ (Note 2)	Max	Units
V _I	Input Clamp Voltage	V _{CC} = Min, I _I = -18 mA			-1.2	V
V _{OH}	High Level Output Voltage	V _{CC} = Min, I _{OH} = Max, V _{IL} = Max, V _{IH} = Min	DM54	2.5	3.4	
			DM74	2.7	3.4	
V _{OL}	Low Level Output Voltage	V _{CC} = Min, I _{OL} = Max V _{IH} = Min, V _{IL} = Max			0.5	V
I _I	Input Current @ Max Input Voltage	V _{CC} = Max, V _I = 5.5V			1	mA
I _{IH}	High Level Input Current	V _{CC} = Max, V _I = 2.7V			50	µA
I _{IL}	Low Level Input Current	V _{CC} = Max, V _I = 0.5V			-2	mA
I _{OS}	Short Circuit Output Current	V _{CC} = Max (Note 3)	DM54	-40	-100	mA
			DM74	-40	-100	
I _{CC}	Supply Current	V _{CC} = Max (Note 4)		45	70	mA

Note 2: All typicals are at V_{CC} = 5V, T_A = 25°C.

Note 3: Not more than one output should be shorted at a time, and the duration should not exceed one second.

Note 4: I_{CC} is measured with the strobe and data select inputs at 4.5V, all other inputs and outputs open.

Switching Characteristics

at $V_{CC} = 5V$ and $T_A = 25^\circ C$

Symbol	Parameter	From (Input) To (Output)	$R_L = 280\Omega$				Units
			$C_L = 15\text{ pF}$		$C_L = 50\text{ pF}$		
			Min	Max	Min	Max	
t_{PLH}	Propagation Delay Time Low to High Level Output	Select to Y (4 Levels)		18		21	ns
t_{PHL}	Propagation Delay Time High to Low Level Output	Select to Y (4 Levels)		18		21	ns
t_{PLH}	Propagation Delay Time Low to High Level Output	Select to W (3 Levels)		15		18	ns
t_{PHL}	Propagation Delay Time High to Low Level Output	Select to W (3 Levels)		13.5		17	ns
t_{PLH}	Propagation Delay Time Low to High Level Output	Strobe to Y		16.5		19	ns
t_{PHL}	Propagation Delay Time High to Low Level Output	Strobe to Y		18		21	ns
t_{PLH}	Propagation Delay Time Low to High Level Output	Strobe to W		13		16	ns
t_{PHL}	Propagation Delay Time High to Low Level Output	Strobe to W		12		16	ns
t_{PLH}	Propagation Delay Time Low to High Level Output	D0 thru D7 to Y		12		15	ns
t_{PHL}	Propagation Delay Time High to Low Level Output	D0 thru D7 to Y		12		15	ns
t_{PLH}	Propagation Delay Time Low to High Level Output	D0 thru D7 to W		7		9	ns
t_{PHL}	Propagation Delay Time High to Low Level Output	D0 thru D7 to W		7		10	ns

Logic Diagram

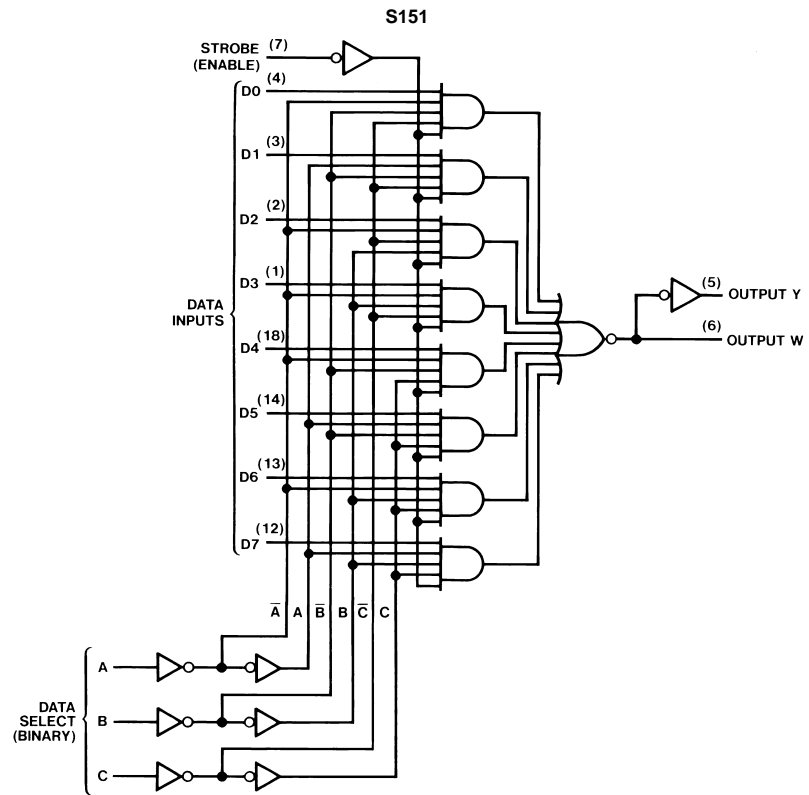

DS006468-2

Physical Dimensions inches (millimeters) unless otherwise noted

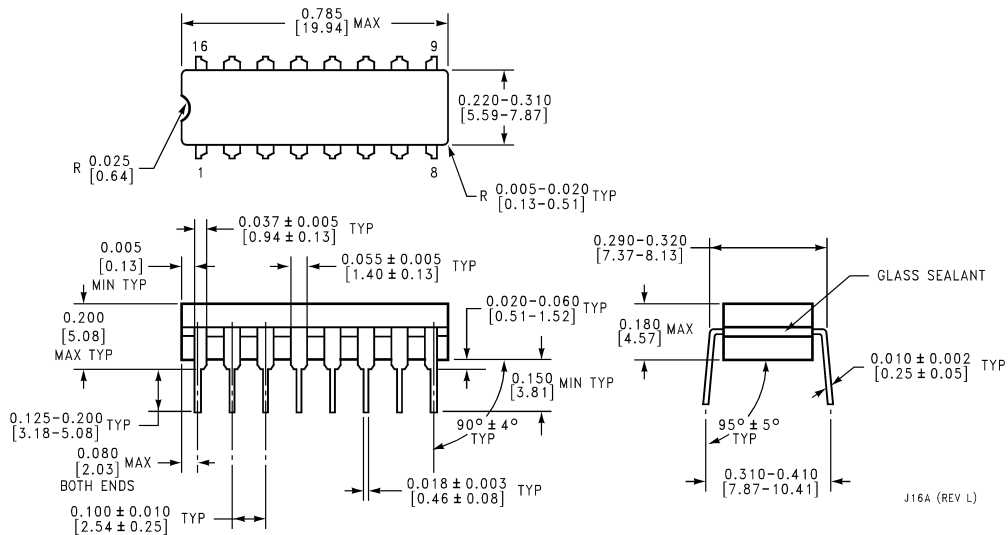

16-Lead Ceramic Dual-In-Line Package (J)
Order Number DM54S151J
Package Number J16A

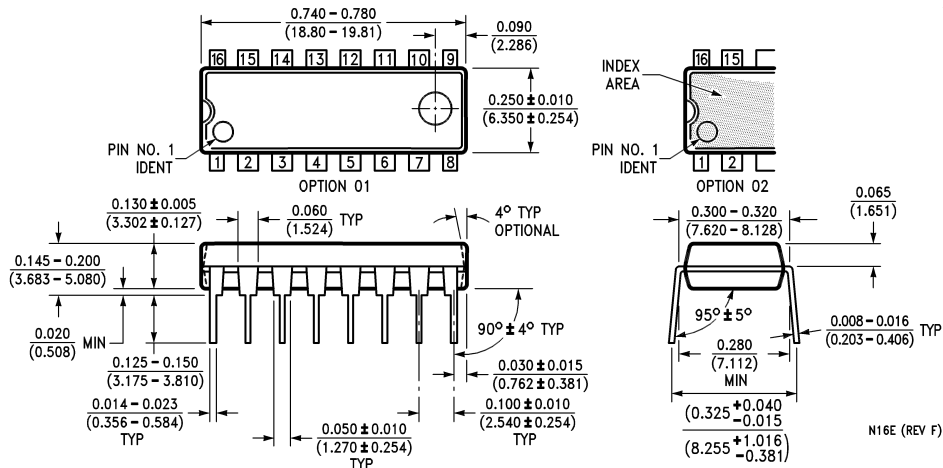

16-Lead Molded Dual-In-Line Package (N)
Order Number DM74S151N
Package Number N16E

Physical Dimensions inches (millimeters) unless otherwise noted (Continued)

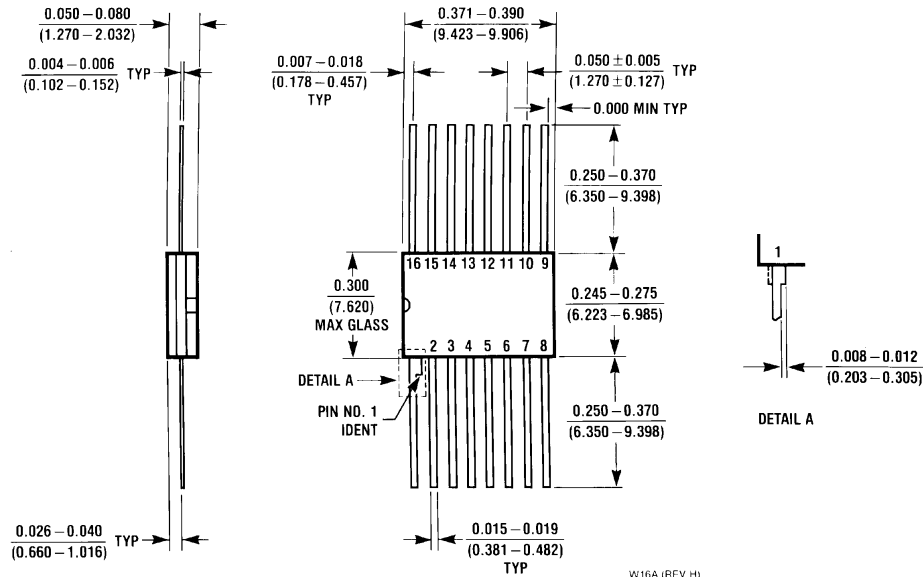

16-Lead Ceramic Flat Package (W)
Order Number DM54S151W
Package Number W16A

LIFE SUPPORT POLICY

FAIRCHILD'S PRODUCTS ARE NOT AUTHORIZED FOR USE AS CRITICAL COMPONENTS IN LIFE SUPPORT DEVICES OR SYSTEMS WITHOUT THE EXPRESS WRITTEN APPROVAL OF THE PRESIDENT OF FAIRCHILD SEMICONDUCTOR CORPORATION. As used herein:

1. Life support devices or systems are devices or systems which, (a) are intended for surgical implant into the body, or (b) support or sustain life, and (c) whose failure to perform when properly used in accordance with instructions for use provided in the labeling, can be reasonably expected to result in a significant injury to the user.
2. A critical component in any component of a life support device or system whose failure to perform can be reasonably expected to cause the failure of the life support device or system, or to affect its safety or effectiveness.

Fairchild Semiconductor Corporation Americas
 Customer Response Center
 Tel: 1-888-522-5372

Fairchild Semiconductor Europe
 Fax: +49 (0) 1 80-530 85 86
 Email: europe.support@nsc.com
 Deutsch Tel: +49 (0) 8 141-35-0
 English Tel: +44 (0) 1 793-85-68-56
 Italy Tel: +39 (0) 2 57 5631

Fairchild Semiconductor Hong Kong Ltd.
 13th Floor, Straight Block,
 Ocean Centre, 5 Canton Rd.
 Tsimshatsui, Kowloon
 Hong Kong
 Tel: +852 2737-7200
 Fax: +852 2314-0061

National Semiconductor Japan Ltd.
 Tel: 81-3-5620-6175
 Fax: 81-3-5620-6179

www.fairchildsemi.com