

## DM74S280 9-Bit Parity Generators/Checkers

### General Description

These universal, nine-bit parity generators/checkers utilize Schottky-clamped TTL high-performance circuitry, and feature odd/even outputs to facilitate operation of either odd or even parity applications. The word-length capability is easily expanded by cascading.

The S280 can be used to upgrade the performance of most systems utilizing the DM74180 parity generator/checker. Although the S280 is implemented without expander inputs, the corresponding function is provided by the availability of all input at pin 4, and no internal connection at pin 3. This permits the S280 to be substituted for the 180 in existing designs to produce an identical function, even if S280's are mixed with existing 180's.

Input buffers are provided so that each input represents only one normal 74S load, and full fan-out to 10 normal Series 74S loads is available from each of the outputs at low logic levels. A fan-out to 20 normal Series 74S loads is provided at high logic levels, to facilitate connection of unused inputs to used inputs.

### Features

- Generates either odd or even parity for nine data lines
- Cascadable for N-bits
- Can be used to upgrade existing systems using MSI parity circuits
- Typical data-to-output delay—14 ns

### Connection Diagram

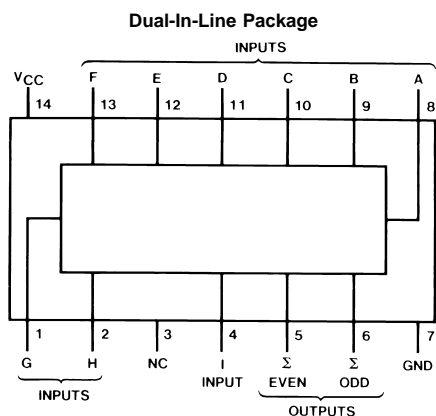

Order Number DM54S280J, DM54S280W, DM74S280M or DM74S280N  
See Package Number J14A, M14A, N14A or W14B

### Function Table

Number of Inputs (A Thru I) that are High	Outputs	
	$\Sigma$ Even	$\Sigma$ Odd
0, 2, 4, 6, 8	H	L
1, 3, 5, 7, 9	L	H

## Absolute Maximum Ratings (Note 1)

Supply Voltage	7V	DM54S	-55°C to +125°C
Input Voltage	5.5V	DM74S	0°C to +70°C
Operating Free Air Temperature Range		Storage Temperature Range	-65°C to +150°C

## Recommended Operating Conditions

Symbol	Parameter	DM54S280			DM74S280			Units
		Min	Nom	Max	Min	Nom	Max	
V <sub>CC</sub>	Supply Voltage	4.5	5	5.5	4.75	5	5.25	V
V <sub>IH</sub>	High Level Input Voltage	2			2			V
V <sub>IL</sub>	Low Level Input Voltage			0.8			0.8	V
I <sub>OH</sub>	High Level Output Current			-1			-1	mA
I <sub>OL</sub>	Low Level Output Current			20			20	mA
T <sub>A</sub>	Free Air Operating Temperature	-55		125	0		70	°C

**Note 1:** The "Absolute Maximum Ratings" are those values beyond which the safety of the device cannot be guaranteed. The device should not be operated at these limits. The parametric values defined in the "Electrical Characteristics" table are not guaranteed at the absolute maximum ratings. The "Recommended Operating Conditions" table will define the conditions for actual device operation.

## Electrical Characteristics

over recommended operating free air temperature range (unless otherwise noted)

Symbol	Parameter	Conditions	Min	Typ (Note 2)	Max	Units
V <sub>I</sub>	Input Clamp Voltage	V <sub>CC</sub> = Min, I <sub>I</sub> = -18 mA			-1.2	V
V <sub>OH</sub>	High Level Output Voltage	V <sub>CC</sub> = Min, I <sub>OH</sub> = Max V <sub>IL</sub> = Max, V <sub>IH</sub> = Min	2.7	3.4		V
V <sub>OL</sub>	Low Level Output Voltage	V <sub>CC</sub> = Min, I <sub>OL</sub> = Max V <sub>IH</sub> = Min, V <sub>IL</sub> = Max			0.5	V
I <sub>I</sub>	Input Current @ Max Input Voltage	V <sub>CC</sub> = Max, V <sub>I</sub> = 5.5V			1	mA
I <sub>IH</sub>	High Level Input Current	V <sub>CC</sub> = Max, V <sub>I</sub> = 2.7V			50	μA
I <sub>IL</sub>	Low Level Input Current	V <sub>CC</sub> = Max, V <sub>I</sub> = 0.5V			-2	mA
I <sub>OS</sub>	Short Circuit Output Current	V <sub>CC</sub> = Max	DM54	-40	-100	mA
		(Note 3)	DM74	-40	-100	
I <sub>CC</sub>	Supply Current	V <sub>CC</sub> Max (Note 4)		67	105	mA

**Note 2:** All typicals are at V<sub>CC</sub> = 5V, T<sub>A</sub> = 25°C.

**Note 3:** Not more than one output should be shorted at a time, and the duration should not exceed one second.

**Note 4:** I<sub>CC</sub> is measured with all inputs grounded and all outputs open.

## Switching Characteristics

at V<sub>CC</sub> = 5V and T<sub>A</sub> = 25°C (See Section 1 for Test Waveforms and Output Load)

Symbol	Parameter	From (Input) To (Output)	R <sub>L</sub> = 280Ω C <sub>L</sub> = 15 pF		R <sub>L</sub> = 280Ω C <sub>L</sub> = 50 pF		Units
			Min	Max	Min	Max	
t <sub>PLH</sub>	Propagation Delay Time Low to High Level Output	Data to Σ Even		21		24	ns
t <sub>PHL</sub>	Propagation Delay Time High to Low Level Output	Data to Σ Even		18		21	ns
t <sub>PLH</sub>	Propagation Delay Time Low to High Level Output	Data to Σ Odd		21		24	ns

## Switching Characteristics (Continued)

at  $V_{CC} = 5V$  and  $T_A = 25^\circ C$  (See Section 1 for Test Waveforms and Output Load)

Symbol	Parameter	From (Input) To (Output)	$R_L = 280\Omega$ $C_L = 15\text{ pF}$		$R_L = 280\Omega$ $C_L = 50\text{ pF}$		Units
			Min	Max	Min	Max	
$t_{PHL}$	Propagation Delay Time High to Low Level Output	Data to $\Sigma$ Odd		18		21	ns

### Logic Diagram

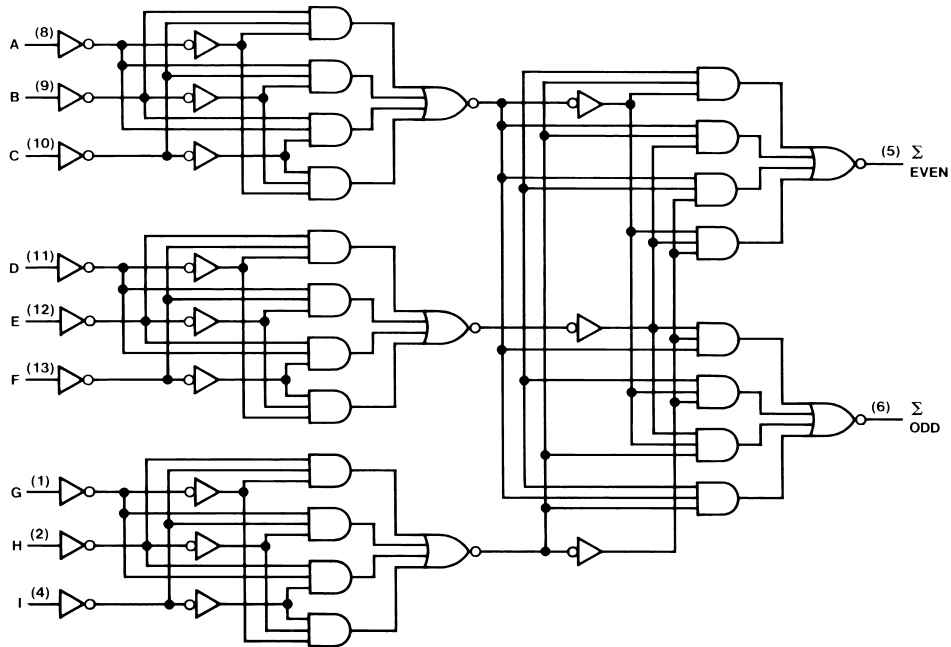

DS006483-2

## Typical Applications

Three S280's can be used to implement a 25-line parity generator/checker. This arrangement will provide parity in typically 25 ns. (See *Figure 1*.)

As an alternative, the outputs of two or three parity generators/checkers can be decoded with a 2-input (S86) or 3-input (S135) exclusive-OR gate for 18 or 27-line parity applications.

Longer word lengths can be implemented by cascading S280's. As shown in *Figure 2*, parity can be generated for word lengths up to 81 bits in typically 25 ns.

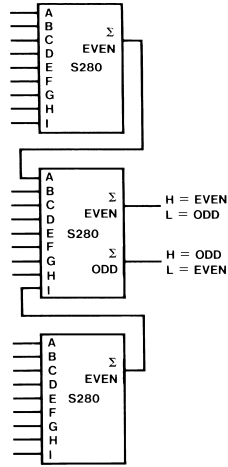

DS006483-3

FIGURE 1. 25-Line Parity/Generator Checker

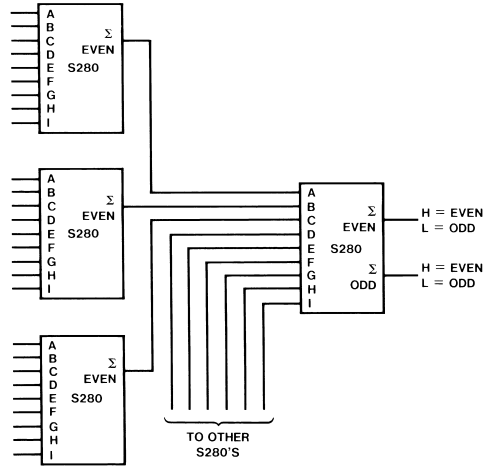

DS006483-4

FIGURE 2. 81-Line Parity/Generator Checker

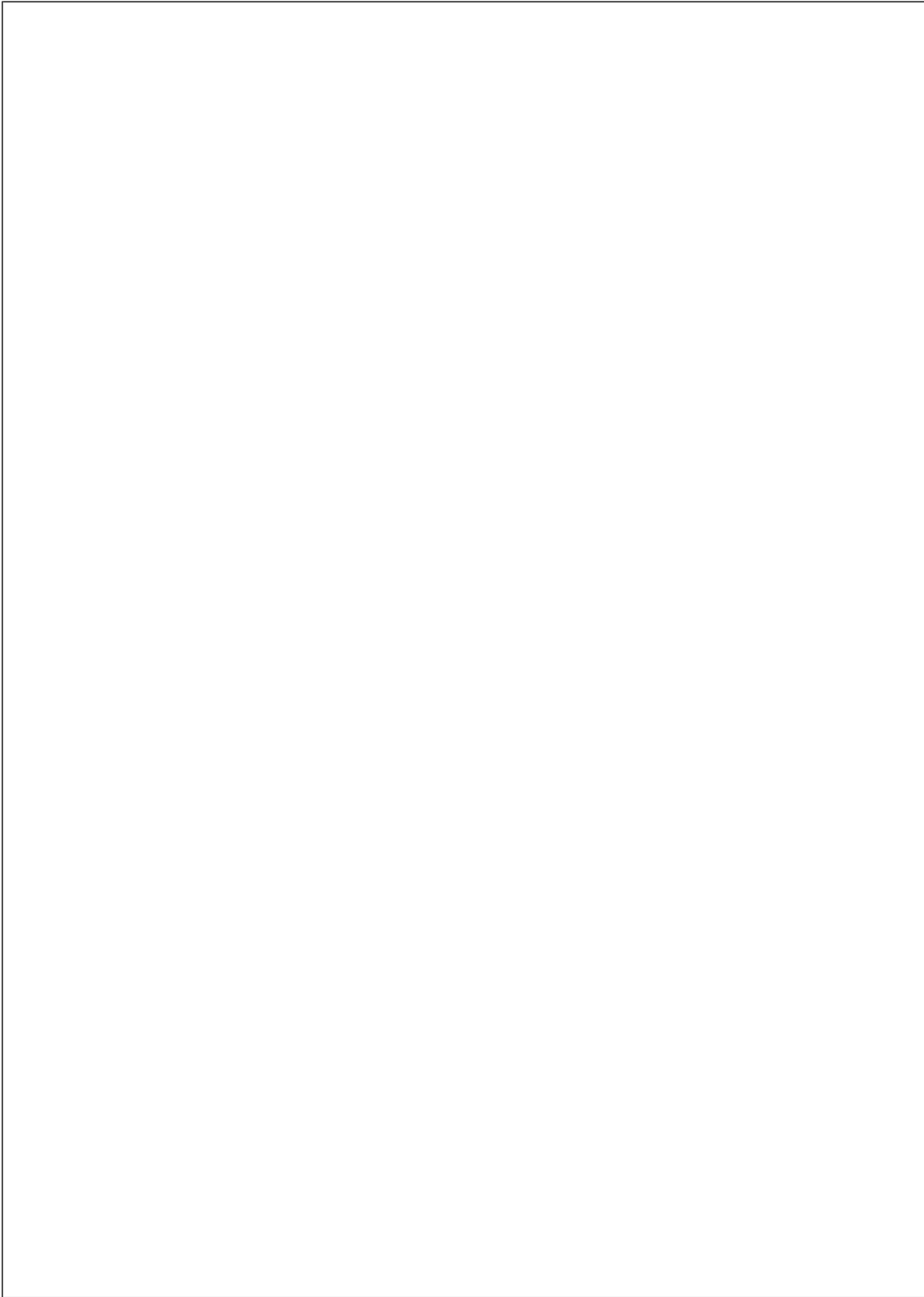

**Physical Dimensions** inches (millimeters) unless otherwise noted

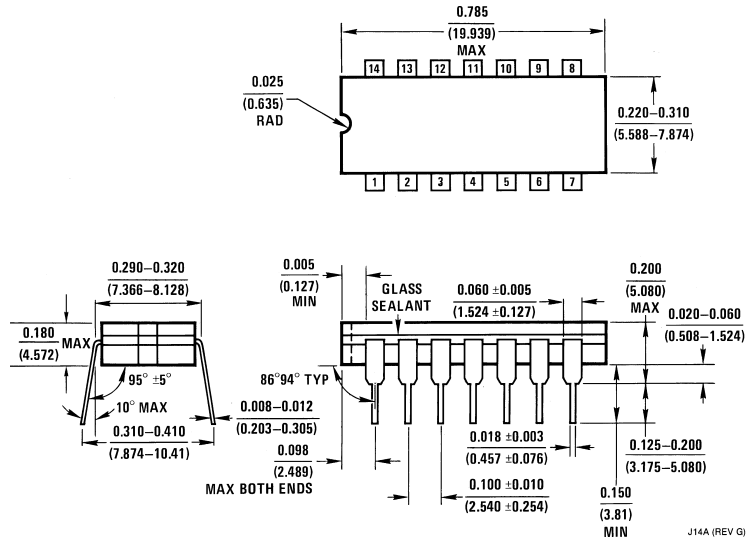

**14-Lead Ceramic Dual-In-Line Package (J)**  
Order Number DM54S280J  
Package Number J14A

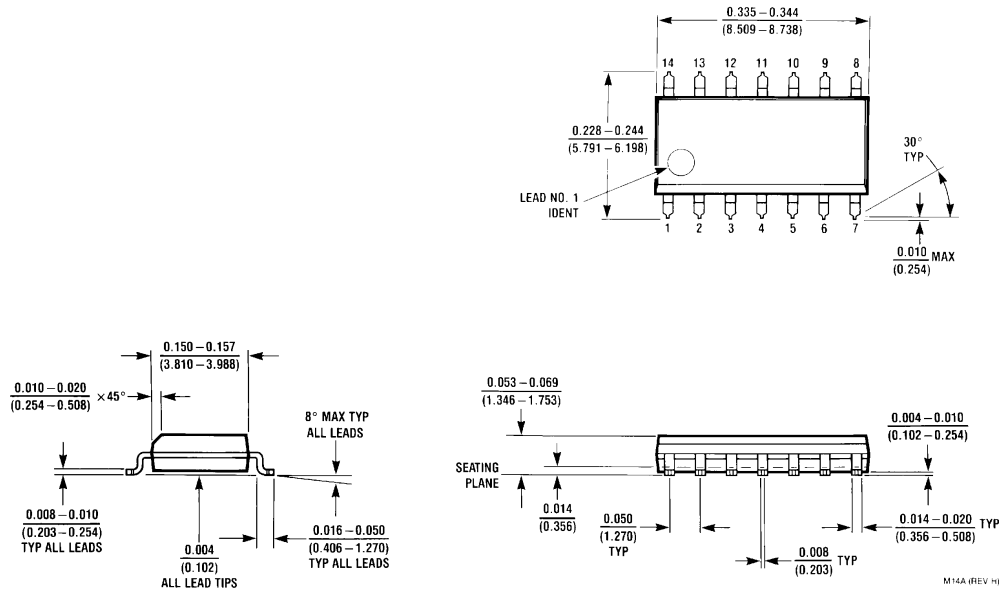

**14-Lead Small Outline Molded Package (M)**  
Order Number DM74S280M  
Package Number M14A

**Physical Dimensions** inches (millimeters) unless otherwise noted (Continued)

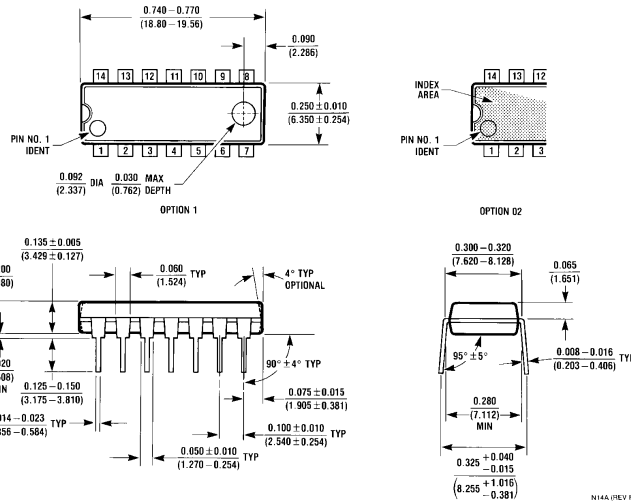

**14-Lead Molded Dual-In-Line Package (N)**  
**Order Number DM74S280N**  
**Package Number N14A**

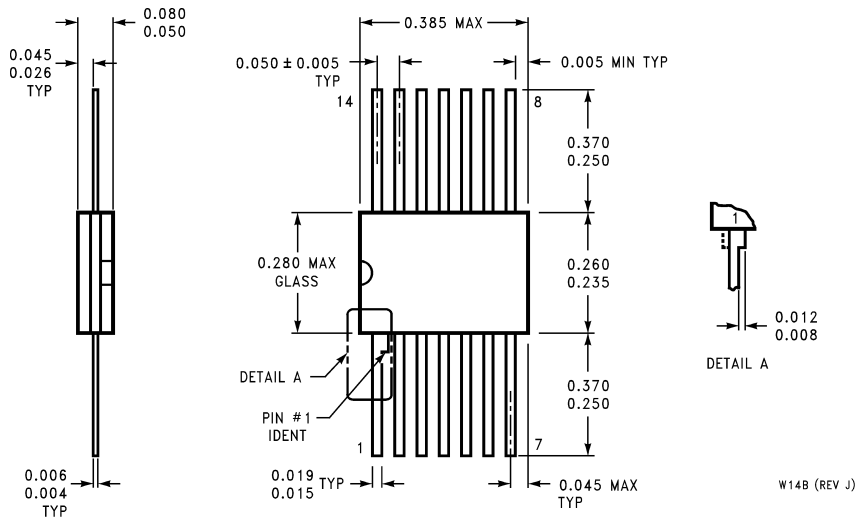

**14-Lead Ceramic Flat Package (W)**  
**Order Number DM54S280W**  
**Package Number W14B**

**LIFE SUPPORT POLICY**

FAIRCHILD'S PRODUCTS ARE NOT AUTHORIZED FOR USE AS CRITICAL COMPONENTS IN LIFE SUPPORT DEVICES OR SYSTEMS WITHOUT THE EXPRESS WRITTEN APPROVAL OF THE PRESIDENT OF FAIRCHILD SEMICONDUCTOR CORPORATION. As used herein:

1. Life support devices or systems are devices or systems which, (a) are intended for surgical implant into the body, or (b) support or sustain life, and (c) whose failure to perform when properly used in accordance with instructions for use provided in the labeling, can be reasonably expected to result in a significant injury to the user.
2. A critical component in any component of a life support device or system whose failure to perform can be reasonably expected to cause the failure of the life support device or system, or to affect its safety or effectiveness.

**Fairchild Semiconductor Corporation Americas**  
Customer Response Center  
Tel: 1-888-522-5372

**Fairchild Semiconductor Europe**  
Fax: +49 (0) 1 80-530 85 86  
Email: europe.support@nsc.com  
Deutsch Tel: +49 (0) 8 141-35-0  
English Tel: +44 (0) 1 793-85-68-56  
Italy Tel: +39 (0) 2 57 5631

**Fairchild Semiconductor Hong Kong Ltd.**  
13th Floor, Straight Block,  
Ocean Centre, 5 Canton Rd.  
Tsimshatsui, Kowloon  
Hong Kong  
Tel: +852 2737-7200  
Fax: +852 2314-0061

**National Semiconductor Japan Ltd.**  
Tel: 81-3-5620-6175  
Fax: 81-3-5620-6179

[www.fairchildsemi.com](http://www.fairchildsemi.com)