

## DM74S373, DM74S374

### 3-STATE Octal D-Type Transparent Latches and Edge-Triggered Flip-Flops

#### General Description

These 8-bit registers feature totem-pole 3-STATE outputs designed specifically for driving highly-capacitive or relatively low-impedance loads. The high-impedance state and increased high-logic-level drive provide these registers with the capability of being connected directly to and driving the bus lines in a bus-organized system without need for interface or pull-up components. They are particularly attractive for implementing buffer registers, I/O ports, bidirectional bus drivers, and working registers.

The eight latches of the DM74S373 are transparent D-type latches meaning that while the enable (G) is high the Q outputs will follow the data (D) inputs. When the enable is taken low the output will be latched at the level of the data that was set up.

The eight flip-flops of the DM74S374 are edge-triggered D-type flip-flops. On the positive transition of the clock, the Q outputs will be set to the logic states that were set up at the D inputs.

Schmitt-trigger buffered inputs at the enable/clock lines simplify system design as ac and dc noise rejection is improved by typically 400 mV due to the input hysteresis. A buffered output control input can be used to place the eight outputs in either a normal logic state (high or low logic levels) or a high-impedance state. In the high-impedance state the outputs neither load nor drive the bus lines significantly.

The output control does not affect the internal operation of the latches or flip-flops. That is, the old data can be retained or new data can be entered even while the outputs are off.

#### Features

- Choice of 8 latches or 8 D-type flip-flops in a single package
- 3-STATE bus-driving outputs
- Full parallel-access for loading
- Buffered control inputs
- P-N-P input reduce D-C loading on data lines

#### Connection Diagrams

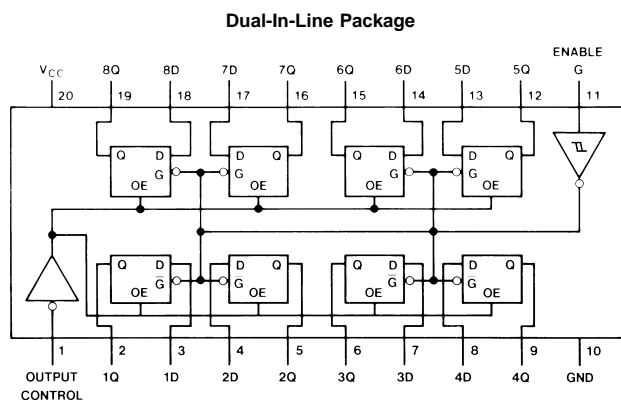

Order Number **DM74S373WM** or **DM74S373N**  
See Package Number  
**M20B** or **N20A**

DM74S373, DM74S374 3-STATE Octal D-Type Transparent Latches and Edge-Triggered Flip-Flops

**Connection Diagrams** (Continued)

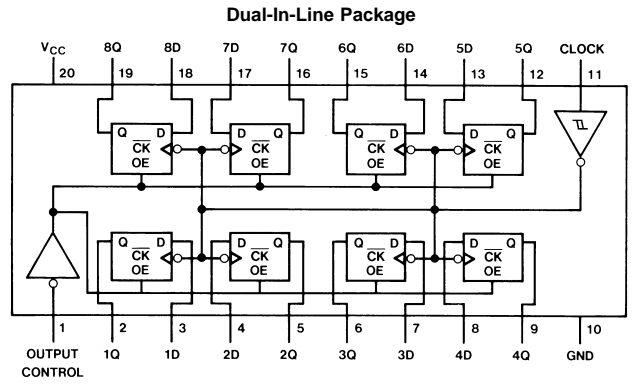

Order Number DM74S374WM or DM74S374N  
See Package Number  
M20B or N20A

## Absolute Maximum Ratings (Note 1)

Supply Voltage	7V
Input Voltage	5.5V
Operating Free Air Temperature Range	
DM74S	0°C to +70°C
Storage Temperature Range	-65°C to +150°C

**Note 1:** The "Absolute Maximum Ratings" are those values beyond which the safety of the device cannot be guaranteed. The device should not be operated at these limits. The parametric values defined in the "Electrical Characteristics" table are not guaranteed at the absolute maximum ratings. The "Recommended Operating Conditions" table will define the conditions for actual device operation.

## Function Tables

### 74S373 Truth Table

Output Control	Enable G	D	Output
L	H	H	H
L	H	L	L
L	L	X	Q <sub>0</sub>
H	X	X	Z

### 74S374 Truth Table

Output Control	Clock	D	Output
L	↑	H	H
L	↑	L	L
L	L	X	Q <sub>0</sub>
H	X	X	Z

H = High Level (Steady State), L = Low Level (Steady State), X = Don't Care

↑ = Transition from low-to-high level, Z = High Impedance State

Q<sub>0</sub> = The level of the output before steady-state input conditions were established.

## Logic Diagrams

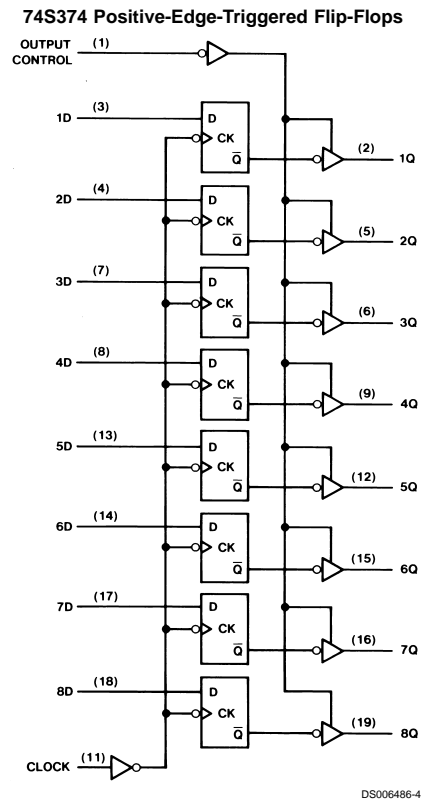
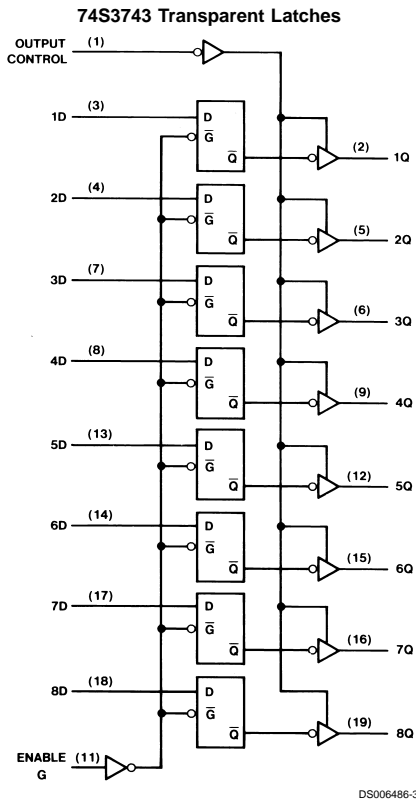

## 'S373 Recommended Operating Conditions

for Test Waveforms and Output Load)

Symbol	Parameter	DM74S373			Units
		Min	Nom	Max	
$V_{CC}$	Supply Voltage	4.75	5	5.25	V
$V_{IH}$	High Level Input Voltage	2			V
$V_{IL}$	Low Level Input Voltage			0.8	V
$I_{OH}$	High Level Output Current			-6.5	mA
$I_{OL}$	Low Level Output Current			20	mA
$t_W$	Pulse Width (Note 3)	Enable High	6		ns
		Enable Low	7.3		
$t_W$	Pulse Width (Note 4)	Enable High	15		ns
		Enable Low	15		ns
$t_{SU}$	Data Setup Time (Notes 2, 5)	0↓			ns
$t_H$	Data Hold Time (Notes 2, 5)	10↓			ns
$T_A$	Free Air Operating Temperature	0		70	°C

**Note 2:** The symbol (↓) indicates the falling edge of the clock pulse is used for reference.

**Note 3:**  $C_L = 15$  pF,  $R_L = 280\Omega$ ,  $T_A = 25^\circ\text{C}$  and  $V_{CC} = 5\text{V}$ .

**Note 4:**  $C_L = 50$  pF and  $R_L = 280\Omega$ ,  $T_A = 25^\circ\text{C}$  and  $V_{CC} = 5\text{V}$ .

**Note 5:**  $T_A = 25^\circ\text{C}$  and  $V_{CC} = 5\text{V}$ .

## 'S373 Electrical Characteristics

over recommended operating free air temperature (unless otherwise noted)

Symbol	Parameter	Conditions	Min	Typ (Note 6)	Max	Units
$V_I$	Input Clamp Voltage	$V_{CC} = \text{Min}$ , $I_I = -18$ mA			-1.2	V
$V_{OH}$	High Level Output Voltage	$V_{CC} = \text{Min}$ $I_{OH} = \text{Max}$ $V_{IL} = \text{Max}$ $V_{IH} = \text{Min}$ DM74	2.4	3.2		V
$V_{OL}$	Low Level Output Voltage	$V_{CC} = \text{Min}$ , $I_{OL} = \text{Max}$ $V_{IH} = \text{Min}$ , $V_{IL} = \text{Max}$			0.5	V
$I_I$	Input Current @ Max Input Voltage	$V_{CC} = \text{Max}$ , $V_I = 5.5\text{V}$			1	mA
$I_{IH}$	High Level Input Current	$V_{CC} = \text{Max}$ , $V_I = 2.7\text{V}$			50	$\mu\text{A}$
$I_{IL}$	Low Level Input Current	$V_{CC} = \text{Max}$ , $V_I = 0.5\text{V}$			-250	$\mu\text{A}$
$I_{OZH}$	Off-State Output Current with High Level Output Voltage Applied	$V_{CC} = \text{Max}$ , $V_O = 2.4\text{V}$ $V_{IH} = \text{Min}$ , $V_{IL} = \text{Max}$			50	$\mu\text{A}$
$I_{OZL}$	Off-State Output Current with Low Level Output Voltage Applied	$V_{CC} = \text{Max}$ , $V_O = 0.5\text{V}$ $V_{IH} = \text{Min}$ , $V_{IL} = \text{Max}$			-50	$\mu\text{A}$
$I_{OS}$	Short Circuit Output Current	$V_{CC} = \text{Max}$ (Note 7) DM74	-40		-100	mA
$I_{CC}$	Supply Current	$V_{CC} = \text{Max}$	Outputs High or Low	105	160	mA
			Outputs Disabled		190	

**Note 6:** All typicals are at  $V_{CC} = 5\text{V}$ ,  $T_A = 25^\circ\text{C}$ .

**Note 7:** Not more than one output should be shorted at a time, and the duration should not exceed one second.

### 'S373 Switching Characteristics

at  $V_{CC} = 5V$  and  $T_A = 25^\circ C$   
for Test Waveforms and Output Load

Symbol	Parameter	From (Input) To (Output)	$R_L = 280\Omega$				Units
			$C_L = 15\text{ pF}$		$C_L = 50\text{ pF}$		
			Min	Max	Min	Max	
$t_{PLH}$	Propagation Delay Time Low to High Level Output	Data to Any Q		12		14	ns
$t_{PHL}$	Propagation Delay Time High to Low Level Output	Data to Any Q		12		16	ns
$t_{PLH}$	Propagation Delay Time Low to High Level Output	Enable to Any Q		14		14	ns
$t_{PHL}$	Propagation Delay Time High to Low Level Output	Enable to Any Q		18		21	ns
$t_{PZH}$	Enable Time to High Level Output	Output Control to Any Q		15		17	ns
$t_{PZL}$	Output Enable Time to Low Level Output	Output Control to Any Q		18		23	ns
$t_{PHZ}$	Output Disable Time to High Level Output (Note 8)	Output Control to Any Q		9			ns
$t_{PLZ}$	Output Disable Time to Low Level Output (Note 8)	Output Control to Any Q		12			ns

Note 8:  $C_L = 5\text{ pF}$

### 'S374 Recommended Operating Conditions

for Test Waveforms and Output Load

Symbol	Parameter		DM74S374			Units
			Min	Nom	Max	
$V_{CC}$	Supply Voltage		4.75	5	5.25	V
$V_{IH}$	High Level Input Voltage					V
$V_{IL}$	Low Level Input Voltage				0.8	V
$I_{OH}$	High Level Output Current				-6.5	mA
$I_{OL}$	Low Level Output Current				20	mA
$f_{CLK}$	Clock Frequency (Note 10)		0		75	MHz
$f_{CLK}$	Clock Frequency (Note 11)		0		75	MHz
$t_w$	Pulse Width (Note 10)	Clock High	6			ns
		Clock Low	7.3			
	Pulse Width (Note 11)	Clock High	15			
		Clock Low	15			
$t_{SU}$	Data Setup Time (Notes 9, 12)		5 $\uparrow$			ns
$t_H$	Data Hold Time (Notes 9, 12)		2 $\uparrow$			ns
$T_A$	Free Air Operating Temperature		0		70	$^\circ C$

Note 9: The symbol ( $\uparrow$ ) indicates the rising edge of the clock pulse is used for reference.

Note 10:  $C_L = 15\text{ pF}$ ,  $R_L = 280\Omega$ ,  $T_A = 25^\circ C$  and  $V_{CC} = 5V$ .

Note 11:  $C_L = 50\text{ pF}$ ,  $R_L = 280\Omega$ ,  $T_A = 25^\circ C$  and  $V_{CC} = 5V$ .

Note 12:  $T_A = 25^\circ C$  and  $V_{CC} = 5V$ .

## 'S374 Electrical Characteristics

over recommended operating free air temperature (unless otherwise noted)

Symbol	Parameter	Conditions	Min	Typ (Note 13)	Max	Units
$V_I$	Input Clamp Voltage	$V_{CC} = \text{Min}, I_I = -18 \text{ mA}$			-1.2	V
$V_{OH}$	High Level Output Voltage	$V_{CC} = \text{Min}$ $I_{OH} = \text{Max}$ $V_{IL} = \text{Max}$ $V_{IH} = \text{Min}$	2.4	3.2		V
$V_{OL}$	Low Level Output Voltage	$V_{CC} = \text{Min}, I_{OL} = \text{Max}$ $V_{IH} = \text{Min}, V_{IL} = \text{Max}$			0.5	V
$I_I$	Input Current @ Max Input Voltage	$V_{CC} = \text{Max}, V_I = 5.5\text{V}$			1	mA
$I_H$	High Level Input Current	$V_{CC} = \text{Max}, V_I = 2.7\text{V}$			50	$\mu\text{A}$
$I_{IL}$	Low Level Input Current	$V_{CC} = \text{Max}, V_I = 0.5\text{V}$			-250	$\mu\text{A}$
$I_{OZH}$	Off-State Output Current with High Level Output Voltage Applied	$V_{CC} = \text{Max}, V_O = 2.4\text{V}$ $V_{IH} = \text{Min}, V_{IL} = \text{Max}$			50	$\mu\text{A}$
$I_{OZL}$	Off-State Output Current with Low Level Output Voltage Applied	$V_{CC} = \text{Max}, V_O = 0.5\text{V}$ $V_{IH} = \text{Min}, V_{IL} = \text{Max}$			-50	$\mu\text{A}$
$I_{OS}$	Short Circuit Output Current	$V_{CC} = \text{Max}$ (Note 14)	DM74	-40	-100	mA
$I_{CC}$	Supply Current	$V_{CC} = \text{Max}$	Outputs High		110	mA
			Outputs Low	90	140	
			Outputs Disabled		160	

**Note 13:** All typicals are at  $V_{CC} = 5\text{V}, T_A = 25^\circ\text{C}$ .

**Note 14:** Not more than one output should be shorted at a time, and the duration should not exceed one second.

## 'S374 Switching Characteristics

at  $V_{CC} = 5\text{V}$  and  $T_A = 25^\circ\text{C}$   
(for Test Waveforms and Output Load)

Symbol	Parameter	From (Input) To (Output)	$R_L = 280\Omega$				Units
			$C_L = 15 \text{ pF}$		$C_L = 50 \text{ pF}$		
			Min	Max	Min	Max	
$f_{MAX}$	Maximum Clock Frequency			75		75	MHz
$t_{PLH}$	Propagation Delay Time Low to High Level Output	Clock to Any Q		15		15	ns
$t_{PHL}$	Propagation Delay Time High to Low Level Output	Clock to Any Q		17		20	ns
$t_{PZH}$	Output Enable Time to High Level Output	Output Control to Any Q		15		17	ns
$t_{PZL}$	Output Enable Time to Low Level Output	Output Control to Any Q		18		23	ns
$t_{PHZ}$	Output Disable Time from High Level Output (Note 15)	Output Control to Any Q		9			ns

### 'S374 Switching Characteristics (Continued)

at  $V_{CC} = 5V$  and  $T_A = 25^\circ C$   
for Test Waveforms and Output Load)

Symbol	Parameter	From (Input) To (Output)	$R_L = 280\Omega$				Units
			$C_L = 15\text{ pF}$		$C_L = 50\text{ pF}$		
			Min	Max	Min	Max	
$t_{PLZ}$	Output Disable Time from Low Level Output (Note 15)	Output Control to Any Q		12			ns

Note 15:  $C_L = 5\text{ pF}$

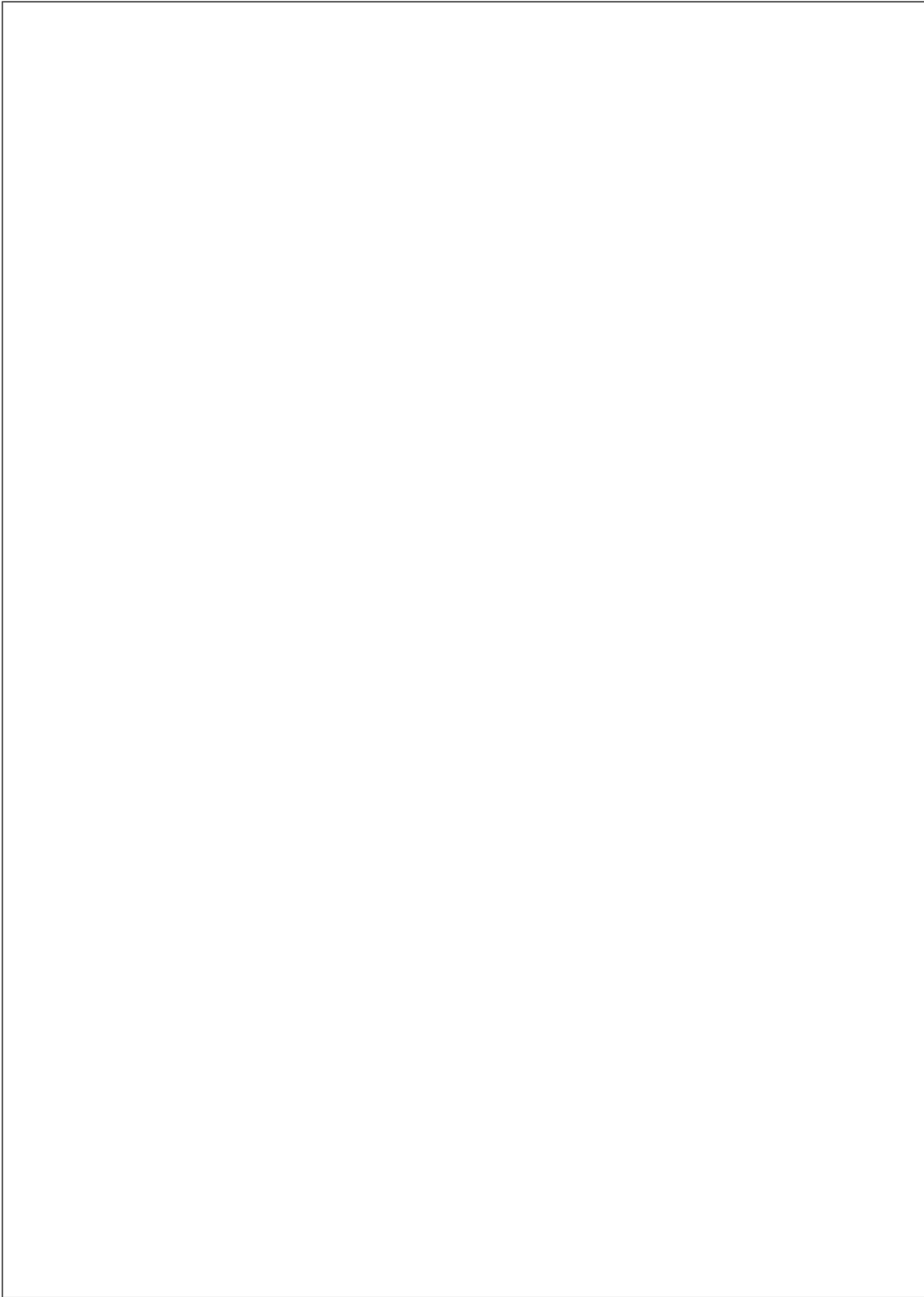

**Physical Dimensions** inches (millimeters) unless otherwise noted

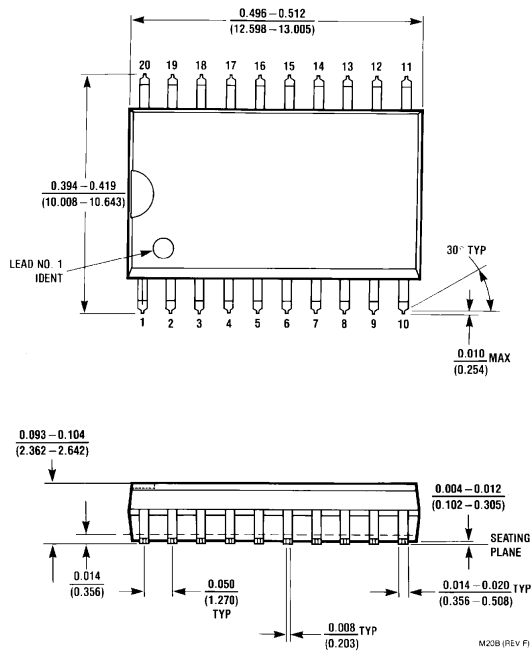

**20-Lead Wide Small Outline Molded Package (M)**  
 Order Number DM74S373WM or DM74S374WM  
 Package Number M20B

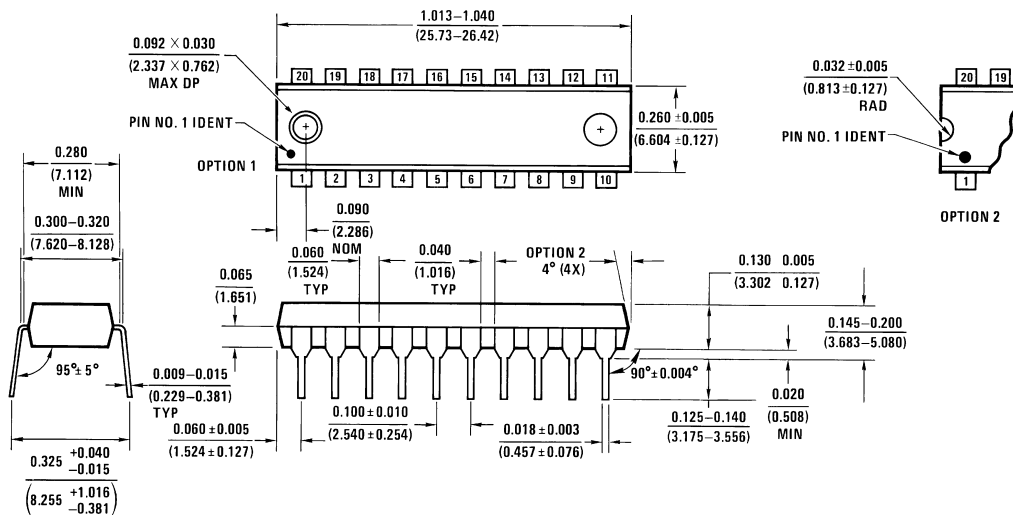

**20-Lead Molded Dual-In-Line Package (N)**  
 Order Number DM74S373N or DM74S374N  
 Package Number N20A

**LIFE SUPPORT POLICY**

FAIRCHILD'S PRODUCTS ARE NOT AUTHORIZED FOR USE AS CRITICAL COMPONENTS IN LIFE SUPPORT DEVICES OR SYSTEMS WITHOUT THE EXPRESS WRITTEN APPROVAL OF THE PRESIDENT OF FAIRCHILD SEMICONDUCTOR CORPORATION. As used herein:

1. Life support devices or systems are devices or systems which, (a) are intended for surgical implant into the body, or (b) support or sustain life, and (c) whose failure to perform when properly used in accordance with instructions for use provided in the labeling, can be reasonably expected to result in a significant injury to the user.
2. A critical component in any component of a life support device or system whose failure to perform can be reasonably expected to cause the failure of the life support device or system, or to affect its safety or effectiveness.

**Fairchild Semiconductor Corporation Americas**  
Customer Response Center  
Tel: 1-888-522-5372

**Fairchild Semiconductor Europe**  
Fax: +49 (0) 1 80-530 85 86  
Email: europe.support@nsc.com  
Deutsch Tel: +49 (0) 8 141-35-0  
English Tel: +44 (0) 1 793-85-68-56  
Italy Tel: +39 (0) 2 57 5631

**Fairchild Semiconductor Hong Kong Ltd.**  
13th Floor, Straight Block,  
Ocean Centre, 5 Canton Rd.  
Tsimshatsui, Kowloon  
Hong Kong  
Tel: +852 2737-7200  
Fax: +852 2314-0061

**National Semiconductor Japan Ltd.**  
Tel: 81-3-5620-6175  
Fax: 81-3-5620-6179

[www.fairchildsemi.com](http://www.fairchildsemi.com)