

DM74S74 Dual Positive-Edge-Triggered D Flip-Flops with Preset, Clear, and Complementary Outputs

General Description

This device contains two independent positive-edge-triggered D flip-flops with complementary outputs. The information on the D input is accepted by the flip-flops on the positive going edge of the clock pulse. The triggering occurs at a voltage level and is not directly related

to the transition time of the rising edge of the clock. The data on the D input may be changed while the clock is low or high without affecting the outputs as long as setup and hold times are not violated. A low logic level on the preset or clear inputs will set or reset the outputs regardless of the logic levels of the other inputs.

Connection Diagram

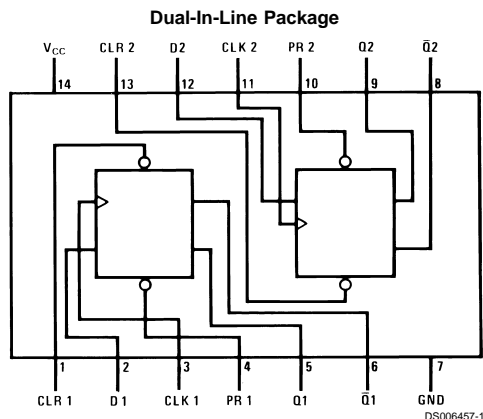

Order Number DM54S74J, DM54S74W, DM74S74M or DM74S74N
See Package Number J14A, M14A, N14A or W14B

Function Table

Inputs				Outputs	
PR	CLR	CLK	D	Q	\bar{Q}
L	H	X	X	H	L
H	L	X	X	L	H
L	L	X	X	H*	H*
H	H	↑	H	H	L
H	H	↑	L	L	H
H	H	L	X	Q ₀	\bar{Q}_0

H = High Logic Level

X = Either Low or High Logic Level

L = Low Logic Level

↑ = Positive-going Transition

* = This configuration is nonstable; that is, it will not persist when either the preset and/or clear inputs return to its inactive (high) level.

Q₀ = The output logic level of Q before the indicated input conditions were established.

Absolute Maximum Ratings (Note 1)

Supply Voltage	7V	DM54S	-55°C to +125°C
Input Voltage	5.5V	DM74S	0°C to +70°C
Operating Free Air Temperature Range		Storage Temperature Range	-65°C to +150°C

Recommended Operating Conditions

(See Section 1 for Test Waveforms and Output Load)

Symbol	Parameter	DM54S74			DM74S74			Units
		Min	Nom	Max	Min	Nom	Max	
V _{CC}	Supply Voltage	4.5	5	5.5	4.75	5	5.25	V
V _{IH}	High Level Input Voltage	2			2			V
V _{IL}	Low Level Input Voltage			0.8			0.8	V
I _{OH}	High Level Output Current			-1			-1	mA
I _{OL}	Low Level Output Current			20			20	mA
f _{CLK}	Clock Frequency (Note 3)	0	110	75	0	110	75	MHz
f _{CLK}	Clock Frequency (Note 4)	0	95	65	0	95	65	MHz
t _w	Pulse Width (Note 3)	Clock High	6		6			ns
		Clock Low	7.3		7.3			
		Clear Low	7		7			
		Preset Low	7		7			
t _w	Pulse Width (Note 4)	Clock High	8		8			ns
		Clock Low	9		9			
		Clear Low	9		9			
		Preset Low	9		9			
t _{SU}	Setup Time (Notes 2, 3)	3↑			3↑			ns
t _{SU}	Setup Time (Notes 2, 4)	3↑			3↑			ns
t _H	Input Hold Time (Notes 2, 3)	2↑			2↑			ns
t _H	Input Hold Time (Notes 2, 4)	2↑			2↑			ns
T _A	Free Air Operating Temperature	-55		125	0		70	°C

Note 1: The "Absolute Maximum Ratings" are those values beyond which the safety of the device cannot be guaranteed. The device should not be operated at these limits. The parametric values defined in the "Electrical Characteristics" table are not guaranteed at the absolute maximum ratings. The "Recommended Operating Conditions" table will define the conditions for actual device operation.

Note 2: The symbol (↑) indicates the rising edge at the clock pulse is used for reference.

Note 3: C_L = 15 pF, R_L = 280Ω, T_A = 25°C and V_{CC} = 5V.

Note 4: C_L = 50 pF, R_L = 280Ω, T_A = 25°C and V_{CC} = 5V.

Electrical Characteristics

over recommended operating free air temperature range (unless otherwise noted)

Symbol	Parameter	Conditions	Min	Typ (Note 5)	Max	Units
V _I	Input Clamp Voltage	V _{CC} = Min, I _I = -18 mA			-1.2	V
V _{OH}	High Level Output Voltage	V _{CC} = Min, I _{OH} = Max	DM54	2.5	3.4	V
		V _{IL} = Max, V _{IH} = Min	DM74	2.7	3.4	
V _{OL}	Low Level Output Voltage	V _{CC} = Min, I _{OL} = Max V _{IH} = Min, V _{IL} = Max			0.5	V
I _I	Input Current @ Max Input Voltage	V _{CC} = Max, V _I = 5.5V			1	mA
I _{IH}	High Level Input Current	V _{CC} = Max V _I = 2.7V	D		50	μA
			Clear		150	
			Preset		100	
			Clock		100	

Electrical Characteristics (Continued)

over recommended operating free air temperature range (unless otherwise noted)

Symbol	Parameter	Conditions	Min	Typ	Max	Units
				(Note 5)		
I _{IL}	Low Level Input Current	V _{CC} = Max V _I = 0.5V (Note 8)	D		-2	mA
				Clear	-6	
				Preset	-4	
				Clock	-4	
I _{OS}	Short Circuit Output Current	V _{CC} = Max (Note 6)	DM54	-40	-100	mA
			DM74	-40	-100	
I _{CC}	Supply Current	V _{CC} = Max, (Note 7)		30	50	mA

Note 5: All typicals are at V_{CC} = 5V, T_A = 25°C.

Note 6: Not more than one output should be shorted at a time, and the duration should not exceed one second.

Note 7: With all outputs open, I_{CC} is measured with the Q and \bar{Q} outputs high in turn. At the time of measurement, the clock is grounded.

Note 8: Clear is tested with preset high and preset is tested with clear high.

Switching Characteristics

at V_{CC} = 5V and T_A = 25°C

Symbol	Parameter	From (Input) To (Output)	R _L = 280Ω				Units
			C _L = 15 pF		C _L = 50 pF		
			Min	Max	Min	Max	
f _{MAX}	Maximum Clock Frequency		75		65		MHz
t _{PLH}	Propagation Delay Time Low to High Level Output	Preset to Q		6		9	ns
t _{PLH}	Propagation Delay Time Low to High Level Output	Clear to \bar{Q}		6		9	ns
t _{PHL}	Propagation Delay Time High to Low Level Output (Clock High)	Preset to \bar{Q}		13.5		17	ns
t _{PHL}	Propagation Delay Time High to Low Level Output (Clock Low)	Preset to \bar{Q}		8		14	ns
t _{PHL}	Propagation Delay Time High to Low Level Output (Clock High)	Clear to Q		13.5		16	ns
t _{PHL}	Propagation Delay Time High to Low Level Output (Clock Low)	Clear to Q		8		13	ns
t _{PLH}	Propagation Delay Time Low to High Level Output	Clock to Q or \bar{Q}		9		12	ns
t _{PHL}	Propagation Delay Time High to Low Level Output	Clock to Q or \bar{Q}		9		14	ns



Physical Dimensions inches (millimeters) unless otherwise noted

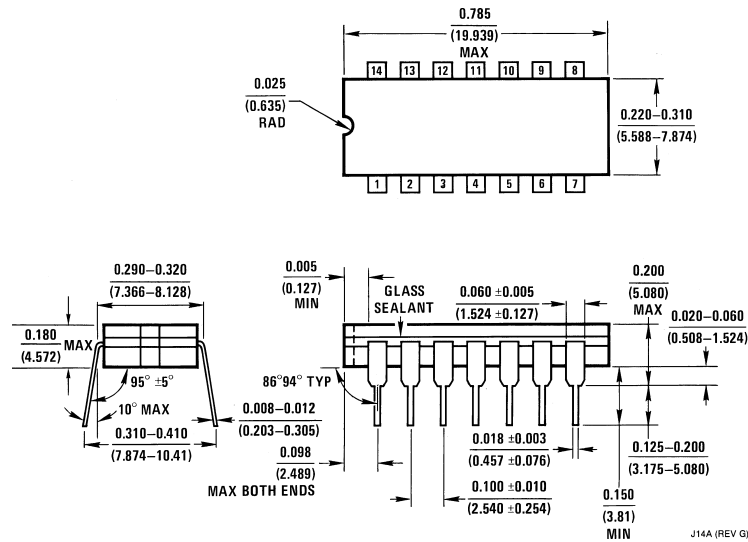

14-Lead Ceramic Dual-In-Line Package (J)
Order Number DM54S74J
Package Number J14A

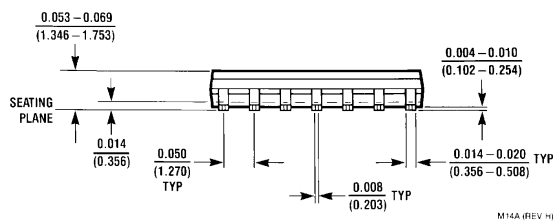
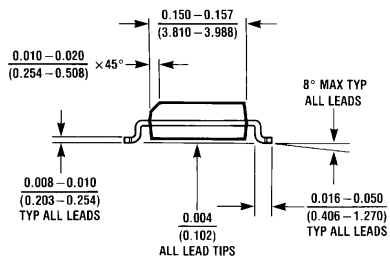
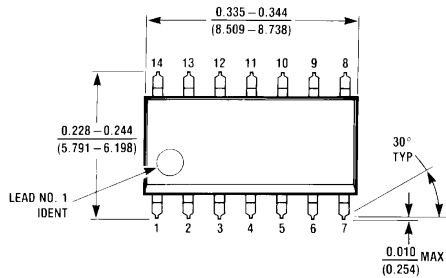

14-Lead Small Outline Molded Package (M)
Order Number DM74S74M
Package Number M14A

DM74S74 Dual Positive-Edge-Triggered D Flip-Flops with Preset, Clear, and Complementary Outputs

Physical Dimensions inches (millimeters) unless otherwise noted (Continued)

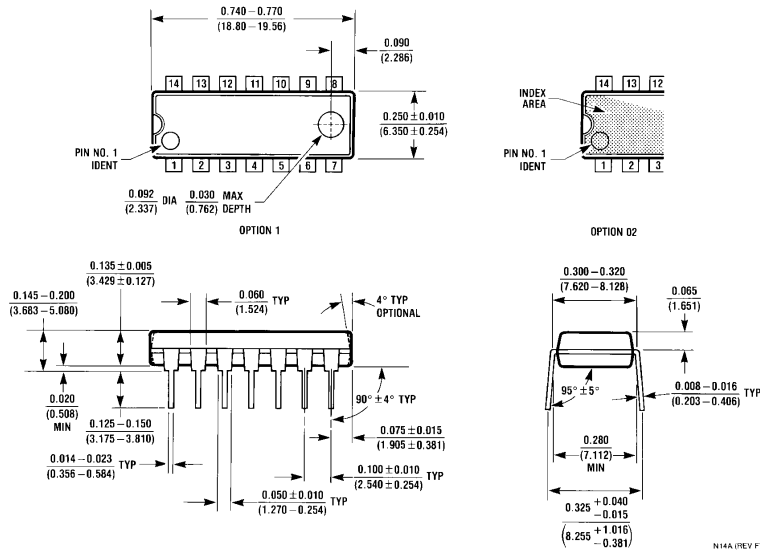

14-Lead Molded Dual-In-Line Package (N)
Order Number DM74S74N
Package Number N14A

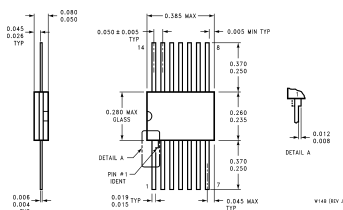

14-Lead Ceramic Flat Package (W)
Order Number DM54S74W
Package Number W14B

LIFE SUPPORT POLICY

FAIRCHILD'S PRODUCTS ARE NOT AUTHORIZED FOR USE AS CRITICAL COMPONENTS IN LIFE SUPPORT DEVICES OR SYSTEMS WITHOUT THE EXPRESS WRITTEN APPROVAL OF THE PRESIDENT OF FAIRCHILD SEMICONDUCTOR CORPORATION. As used herein:

1. Life support devices or systems are devices or systems which, (a) are intended for surgical implant into the body, or (b) support or sustain life, and (c) whose failure to perform when properly used in accordance with instructions for use provided in the labeling, can be reasonably expected to result in a significant injury to the user.
2. A critical component in any component of a life support device or system whose failure to perform can be reasonably expected to cause the failure of the life support device or system, or to affect its safety or effectiveness.

Fairchild Semiconductor Corporation Americas
 Customer Response Center
 Tel: 1-888-522-5372

Fairchild Semiconductor Europe
 Fax: +49 (0) 1 80-530 85 86
 Email: europe.support@nsc.com
 Deutsch Tel: +49 (0) 8 141-35-0
 English Tel: +44 (0) 1 793-85-68-56
 Italy Tel: +39 (0) 2 57 5631

Fairchild Semiconductor Hong Kong Ltd.
 13th Floor, Straight Block,
 Ocean Centre, 5 Canton Rd.
 Tsimshatsui, Kowloon
 Hong Kong
 Tel: +852 2737-7200
 Fax: +852 2314-0061

National Semiconductor Japan Ltd.
 Tel: 81-3-5620-6175
 Fax: 81-3-5620-6179

www.fairchildsemi.com