

DM9370

7-Segment Decoder/Driver/Latch with Open-Collector Outputs

General Description

The DM9370 is a 7-segment decoder driver incorporating input latches and output circuits to directly drive incandescent

displays. It can also be used to drive common anode LED displays in either a multiplexed mode or directly with the aid of external current limiting resistors.

Connection Diagram

Dual-In-Line Package

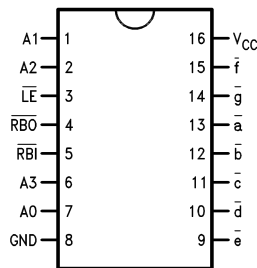

DS009797-1

Order Number **DM9370N**
See Package Number **N16E**

Pin Names	Description
A0–A3	Address Inputs
\overline{LE}	Latch Enable Input (Active LOW)
\overline{RBI}	Ripple Blanking Input (Active LOW)
\overline{RBO}	Ripple Blanking as Output (Active LOW) as Input (Active LOW)
$\overline{a-g}$	Segment Outputs (Active LOW)

DM9370 7-Segment Decoder/Driver/Latch with Open-Collector Outputs

Absolute Maximum Ratings (Note 1)

Supply Voltage 7V
Input Voltage 5.5V

Operating Free Air Temperature Range

Commercial 0°C to +70°C
Storage Temperature Range -65°C to +150°C

Recommended Operating Conditions

Symbol	Parameter	DM9370			Units
		Min	Nom	Max	
V _{CC}	Supply Voltage	4.75	5	5.25	V
V _{IH}	High Level Input Voltage	2			V
V _{IL}	Low Level Input Voltage			0.8	V
I _{OH}	High Level Output Current			-80	μA
I _{OL}	Low Level Output Current			3.2	mA
T _A	Free Air Operating Temperature	0		70	°C
t _s (H)	Setup Time HIGH or LOW			30	ns
t _s (L)	A _n to \overline{LE}			20	ns
t _h (H)	Hold Time HIGH or LOW			0	ns
t _h (L)	A _n to \overline{LE}			0	ns
t _w (L)	\overline{LE} Pulse Width LOW			45	ns

Note 1: The "Absolute Maximum Ratings" are those values beyond which the safety of the device cannot be guaranteed. The device should not be operated at these limits. The parametric values defined in the "Electrical Characteristics" table are not guaranteed at the absolute maximum ratings. The "Recommended Operating Conditions" table will define the conditions for actual device operation.

Electrical Characteristics

Over recommended operating free air temperature range (unless otherwise noted)

Symbol	Parameter	Conditions	Min	Typ (Note *NO TARGET FOR FNXref NS998*)	Max	Units	
V _I	Input Clamp Voltage	V _{CC} = Min, I _I = -12 mA			-1.5	V	
V _{OH}	High Level Output Voltage	V _{CC} = Min, I _{OH} = Max V _{IL} = Max	2.4	3.4		V	
V _{OL}	Low Level Output Voltage	V _{CC} = Min, I _{OL} = Max V _{IH} = Min		0.2	0.4	V	
I _I	Input Current @ Max Input Voltage	V _{CC} = Max, V _I = 5.5V			1	mA	
I _{IH}	High Level Input Current	V _{CC} = Max, V _I = 2.4V			40	μA	
I _{IL}	Low Level Input Current	V _{CC} = Max, V _I = 0.4V			-1.6	mA	
I _{OS}	Short Circuit Output Current	V _{CC} = Max (Note *NO TARGET FOR FNXref NS999*)	DM74		-20	-70	mA
V _{OH}	Output HIGH Voltage	RBO V _{CC} = Min, I _{OH} = -80 μA	2.4			V	
V _{OL}	Output LOW Voltage	RBO I _{OL} = 3.2 mA	V _{CC} = Min		0.4	V	
		$\overline{a-g}$ I _{OL} = 25 mA			0.4		
I _{OH}	Output HIGH Current, $\overline{a-g}$				250	μA	

Electrical Characteristics (Continued)

Over recommended operating free air temperature range (unless otherwise noted)

Symbol	Parameter	Conditions	Min	Typ (Note *NO TARGET FOR FNXref NS998*)	Max	Units
I _{CC}	Power Supply Current	V _{CC} = Max			105	μA
		A ₁ , A ₂ , A ₃ , $\overline{\text{LE}}$ = GND			105	mA
		V _{CC} = Max, Outputs Open				
		A ₀ , A ₁ , A ₂ , $\overline{\text{LE}}$ = GND			94	
		V _{CC} = Max, Outputs Open				

Switching Characteristics

V_{CC} = +5.0V, T_A = +25°C (See Section 1 for waveforms and load configurations)

Symbol	Parameter	C _L = 15 PF R _L = 500Ω		Units
		Min	Max	
t _{PLH}	Propagation Delay		75	ns
t _{PHL}	A _n to $\overline{\text{a-g}}$		50	
t _{PLH}	Propagation Delay		90	ns
t _{PHL}	$\overline{\text{LE}}$ to $\overline{\text{a-g}}$		70	

Functional Description

The '70 has active LOW outputs capable of sinking in excess of 25 mA which allows it to drive a wide variety of 7-segment incandescent displays directly. It may also be used to drive common anode LED displays, multiplexed or directly with the aid of suitable current limiting resistors. This device accepts a 4-bit binary code and produces output drive to the appropriate segments of the 7-segment display. It has a hexadecimal decode format which produces numeric codes "0" through "9" and alpha codes "A" through "F" using upper and lower case fonts.

Latches on the four data inputs are controlled by an active LOW latch enable $\overline{\text{LE}}$. When the $\overline{\text{LE}}$ is LOW, the state of the outputs is determined by the input data. When the $\overline{\text{LE}}$ goes HIGH, the last data present at the inputs is stored in the latches and the outputs remain stable. The $\overline{\text{LE}}$ pulse width necessary to accept and store data is typically 30 ns which allows data to be strobed into the '70 at normal TTL speeds. This feature means that data can be routed directly from high speed counters and frequency dividers into the display without slowing down the system clock or providing intermediate data storage.

The latch/decoder combination is a simple system which drives incandescent displays with multiplexed data inputs from MOS time clocks, DVMs, calculator chips, etc. Data inputs are multiplexed while the displays are in static mode. This lowers component and insertion costs since several circuits—seven diodes per display, strobe drivers, a separate display voltage source, and clock failure detect

circuits—traditionally found in incandescent multiplexed display systems are eliminated. It also allows low strobing rates to be used without display flicker.

Another '70 feature is the reduced loading on the data inputs when the Latch Enable is HIGH (only 10 μA typ). This allows many '70s to be driven from a MOS device in multiplex mode without the need for drivers on the data lines. The '70 also provides automatic blanking of the leading and/or trailing-edge zeroes in a multidigit decimal number, resulting in an easily readable decimal display conforming to normal writing practice. In an 8-digit mixed integer fraction decimal representation, using the automatic blanking capability, 0060.0300 would be displayed as 60.03. Leading-edge zero suppression is obtained by connecting the Ripple Blanking Output (RBO) of a decoder to the Ripple Blanking Input (RBI) of the next lower stage device. The most significant decoder stage should have the RBI input grounded; and since suppression of the least significant integer zero in a number is not usually desired, the RBI input of this decoder stage should be left open. A similar procedure for the fractional part of a display will provide automatic suppression of trailing-edge zeroes. The RBO terminal of the decoder can be OR-tied with a modulating signal via an isolating buffer to achieve pulse duration intensity modulation. A suitable signal can be generated for this purpose by forming a variable frequency multivibrator with a cross coupled pair of TTL or DTL gates.

Logic Symbol

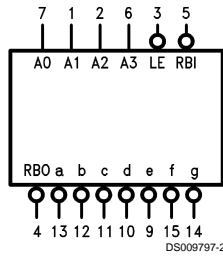

V_{CC} = Pin 16
GND = Pin 8

Truth Table

BINARY STATE	INPUTS						OUTPUTS							DISPLAY	
	\overline{LE}	\overline{RBI}	A3	A2	A1	A0	\overline{a}	\overline{b}	\overline{c}	\overline{d}	\overline{e}	\overline{f}	\overline{g}		RBO
--	H	*	X	X	X	X	← STABLE →							H	STABLE BLANK
0	L	L	L	L	L	L	H	H	H	H	H	H	H	L	0
1	L	X	L	L	L	H	H	L	L	H	H	H	H	H	1
2	L	X	L	L	H	L	L	L	H	L	H	L	L	H	2
3	L	X	L	L	H	H	L	L	L	L	H	H	L	H	3
4	L	X	L	H	L	L	H	L	L	H	H	L	L	H	4
5	L	X	L	H	L	H	L	H	L	L	H	L	L	H	5
6	L	X	L	H	H	L	L	H	L	L	L	L	L	H	6
7	L	X	L	H	H	H	L	L	L	H	H	H	H	H	7
8	L	X	H	L	L	L	L	L	L	L	L	L	L	H	8
9	L	X	H	L	L	H	L	L	L	H	H	L	L	H	9
10	L	X	H	L	H	L	L	L	L	H	L	L	L	H	A
11	L	X	H	L	H	H	H	H	L	L	L	L	L	H	B
12	L	X	H	H	L	L	L	H	H	L	L	L	H	H	C
13	L	X	H	H	L	H	H	L	L	L	L	L	H	H	D
14	L	X	H	H	H	L	L	H	H	L	L	L	L	H	E
15	L	X	H	H	H	H	L	H	H	H	L	L	L	H	F
X	X	X	X	X	X	X	H	H	H	H	H	H	H	L**	BLANK

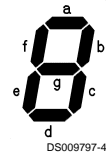

*The \overline{RBI} will blank the display only if binary zero is stored in the latches.

** \overline{RBO} used as an input overdrives all other input conditions.

H = HIGH Voltage Level

L = LOW Voltage Level

X = Immaterial

Numerical Designation

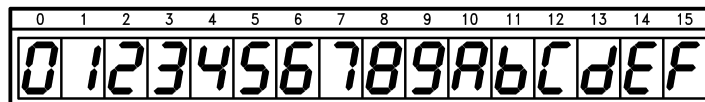

DS009797-5

Logic Diagram

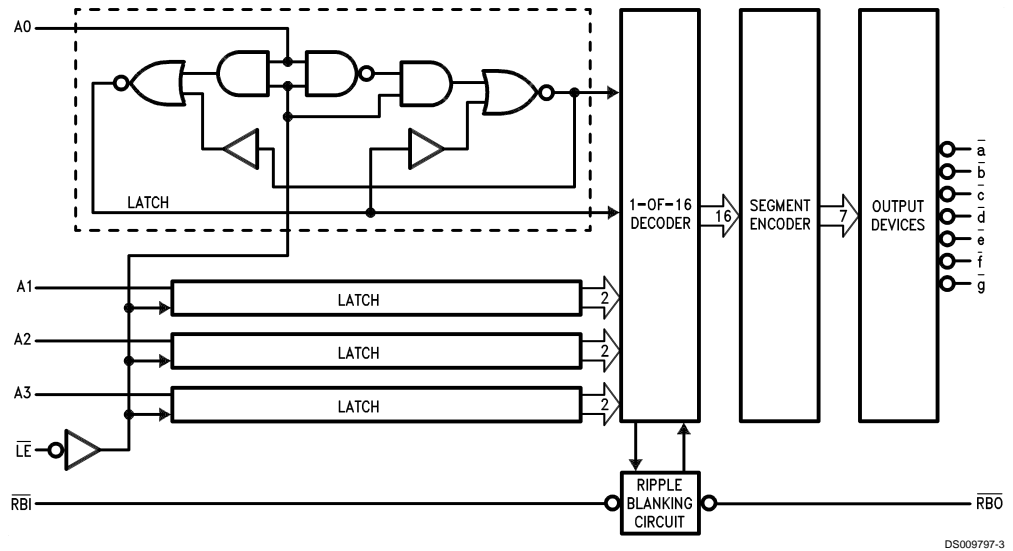

DS009797-3

Physical Dimensions inches (millimeters) unless otherwise noted

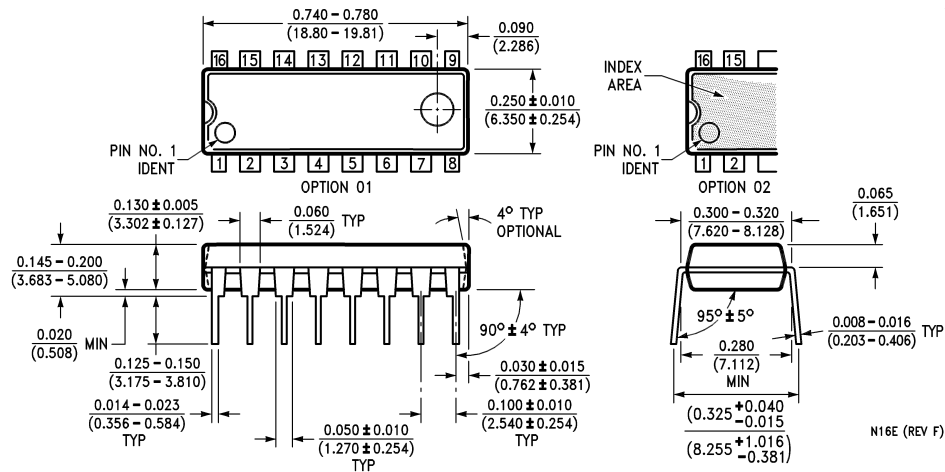

16-Lead Molded Dual-In-Line Package (N)
Order Number DM9370N
Package Number N16E

LIFE SUPPORT POLICY

FAIRCHILD'S PRODUCTS ARE NOT AUTHORIZED FOR USE AS CRITICAL COMPONENTS IN LIFE SUPPORT DEVICES OR SYSTEMS WITHOUT THE EXPRESS WRITTEN APPROVAL OF THE PRESIDENT OF FAIRCHILD SEMICONDUCTOR CORPORATION. As used herein:

1. Life support devices or systems are devices or systems which, (a) are intended for surgical implant into the body, or (b) support or sustain life, and (c) whose failure to perform when properly used in accordance with instructions for use provided in the labeling, can be reasonably expected to result in a significant injury to the user.
2. A critical component in any component of a life support device or system whose failure to perform can be reasonably expected to cause the failure of the life support device or system, or to affect its safety or effectiveness.

Fairchild Semiconductor Corporation Americas
 Customer Response Center
 Tel: 1-888-522-5372

Fairchild Semiconductor Europe
 Fax: +49 (0) 1 80-530 85 86
 Email: europe.support@nsc.com
 Deutsch Tel: +49 (0) 8 141-35-0
 English Tel: +44 (0) 1 793-85-68-56
 Italy Tel: +39 (0) 2 57 5631

Fairchild Semiconductor Hong Kong Ltd.
 13th Floor, Straight Block,
 Ocean Centre, 5 Canton Rd.
 Tsimshatsui, Kowloon
 Hong Kong
 Tel: +862 2737-7200
 Fax: +852 2314-0061

National Semiconductor Japan Ltd.
 Tel: 81-3-5620-6175
 Fax: 81-3-5620-6179

www.fairchildsemi.com