

96LS02/DM96LS02 Dual Retriggerable Resettable Monostable Multivibrator

General Description

The 96LS02 is a dual retriggerable and resettable monostable multivibrator. The one-shot provides exceptionally wide delay range, pulse width stability, predictable accuracy and immunity to noise. The pulse width is set by an external resistor and capacitor. Resistor values up to 1.0 MΩ reduce required capacitor values. Hysteresis is provided on both trigger inputs of the 96LS02 for increased noise immunity.

- Broad timing resistor range—1.0 kΩ to 2.0 MΩ
- Output Pulse Width is variable over a 2000:1 range by resistor control
- Propagation delay of 35 ns
- 0.3V hysteresis on trigger inputs
- Output pulse width independent of duty cycle
- 35 ns to ∞ output pulse width range

Features

- Required timing capacitance reduced by factors of 10 to 100 over conventional designs

Connection Diagram

Dual-In-Line Package

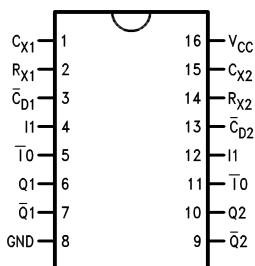

DS009816-1

Order Number 96LS02DMQB, 96LS02FMQB, DM96LS02M or DM96LS02N
See Package Number J16A, M16A, N16E or W16A

Pin Names	Description
$\bar{I}0$	Trigger Input (Active Falling Edge)
$\bar{I}0$	Schmitt Trigger Input (Active Falling Edge)
I1	Schmitt Trigger Input (Active Rising Edge)
$\bar{C}D$	Direct Clear Input (Active LOW)
Q	True Pulse Output
\bar{Q}	Complementary Pulse Output

Absolute Maximum Ratings (Note 1)

Supply Voltage	7V	96LS Military	-55°C to +125°C
Input Voltage	7V	DM96LS Commercial	0°C to +70°C
Operating Free Air Temperature Range		Storage Temperature Range	-65°C to +150°C

Recommended Operating Conditions

Symbol	Parameter	96LS02 (MIL)			DM96LS02 (COM)			Units
		Min	Nom	Max	Min	Nom	Max	
V _{CC}	Supply Voltage	4.5	5	5.5	4.75	5	5.25	V
V _{IH}	High Level Input Voltage	2			2			V
V _{IL}	Low Level Input Voltage			0.7			0.8	V
I _{OH}	High Level Output Current			-0.4			-0.4	mA
I _{OL}	Low Level Output Current			4			8	mA
T _A	Free Air Operating Temperature	-55		125	0		70	°C

Note 1: The "Absolute Maximum Ratings" are those values beyond which the safety of the device cannot be guaranteed. The device should not be operated at these limits. The parametric values defined in the "Electrical Characteristics" table are not guaranteed at the absolute maximum ratings. The "Recommended Operating Conditions" table will define the conditions for actual device operation.

Electrical Characteristics

Over recommended operating free air temperature range (unless otherwise noted)

Symbol	Parameter	Conditions	Min	Typ (Note 2)	Max	Units	
V _I	Input Clamp Voltage	V _{CC} = Min, I _I = -18 mA			-1.5	V	
V _{OH}	High Level Output Voltage	V _{CC} = Min, I _{OH} = Max,	MIL	2.5		V	
		V _{IL} = Max	COM	2.7	3.4		
V _{OL}	Low Level Output Voltage	V _{CC} = Min, I _{OL} = Max,	MIL		0.4	V	
		V _{IH} = Min	COM		0.35		
		I _{OL} = 4 mA, V _{CC} = Min	COM		0.25		
I _I	Input Current @ Max Input Voltage	V _{CC} = Max, V _I = 7V	COM		0.1	mA	
		V _I = 10V	MIL				
I _{IH}	High Level Input Current	V _{CC} = Max, V _I = 2.7V			20	µA	
I _{IL}	Low Level Input Current	V _{CC} = Max, V _I = 0.4V			-0.4	mA	
I _{OS}	Short Circuit Output Current	V _{CC} = Max	MIL	-20		-100	mA
		(Note 3)	COM	-20		-100	
I _{CC}	Supply Current	V _{CC} = Max			36	mA	
V _{T+}	Positive-Going Threshold Voltage, I ₀ , I ₁				2.0	V	
V _{T-}	Negative-Going Threshold Voltage, I ₀ , I ₁		MIL	0.7		V	
			COM	0.8			

Note 2: All typicals are at V_{CC} = 5V, T_A = 25°C.

Note 3: Not more than one output should be shorted at a time, and the duration should not exceed one second.

Switching Characteristics

V_{CC} = +5.0V, T_A = +25°C

Symbol	Parameter	96LS (MIL)		DM96LS (COM)		Units
		C _L = 15 pF		C _L = 15 pF		
		Min	Max	Min	Max	
t _{PLH}	Propagation Delay I ₀ to Q		45		55	ns

Switching Characteristics (Continued)

$V_{CC} = +5.0V$, $T_A = +25^\circ C$

Symbol	Parameter	96LS (MIL)		DM96LS (COM)		Units
		$C_L = 15 \text{ pF}$		$C_L = 15 \text{ pF}$		
		Min	Max	Min	Max	
t_{PHL}	Propagation Delay $\bar{I}0$ to \bar{Q}		33		50	ns
t_{PLH}	Propagation Delay I1 to Q		45		60	ns
t_{PHL}	Propagation Delay I1 to \bar{Q}		33		55	ns
t_{PHL}	Propagation Delay \bar{C}_D to Q		25		30	ns
t_{PLH}	Propagation Delay \bar{C}_D to \bar{Q}		30		35	ns
$t_w(L)$	$\bar{I}0$ Pulse Width LOW	15		15		ns
$t_w(H)$	I1 Pulse Width HIGH	30		30		ns
$t_w(L)$	\bar{C}_D Pulse Width LOW	22		22		ns
$t_w(H)$	Minimum Q Pulse Width HIGH	20	70	25	55	ns
t_w	Q Pulse Width	4.25	5.0	4.1	4.5	μs
R_X	Timing Resistor Range (Note 4)			1	1000	k Ω
t	Change in Q Pulse Width over Temperature				1.0	%
t	Change in Q Pulse Width over V_{CC} Range				0.8 1.5	%

Note 4: Applies only over commercial V_{CC} and T_A range for 96S02.

Functional Description

The 96LS02 dual retriggerable resettable monostable multivibrator has two DC coupled trigger inputs per function, one active LOW ($\bar{I}0$) and one active HIGH (I1). The I1 input and $\bar{I}0$ input of the 96LS02 utilize an internal Schmitt trigger with hysteresis of 0.3V to provide increased noise immunity. The use of active HIGH and LOW inputs allows either rising or falling edge triggering and optional non-retriggerable operation. The inputs are DC coupled making triggering independent of input transition times. When input conditions for triggering are met, the Q output goes HIGH and the external capacitor is rapidly discharged and then allowed to recharge. An input trigger which occurs during the timing cycle will retrigger the circuit and result in Q remaining HIGH. The output pulse may be terminated (Q to the LOW state) at any time by setting the Direct Clear input LOW. Retriggling may be inhibited by tying the \bar{Q} output to $\bar{I}0$ or the Q output to I1. Differential sensing techniques are used to obtain excellent stability over temperature and power supply variations and a feedback Darlington capacitor discharge circuit minimizes pulse width variation from unit to unit. Schottky TTL output stages provide high switching speeds and output compatibility with all TTL logic families.

Operation Notes

TIMING

1. An external resistor (R_X) and an external capacitor (C_X) are required as shown in the Logic Diagram. The value of R_X may vary from 1.0 k Ω to 1.0 M Ω (96LS02).

2. The value of C_X may vary from 0 to any necessary value available. If, however, the capacitor has significant leakage relative to V_{CC}/R_X the timing equations may not represent the pulse width obtained.

3. The output pulse width t_w for $R_X \geq 10 \text{ k}\Omega$ and $C_X \geq 1000 \text{ pF}$ is determined as follows:

$$t_w = 0.43 R_X C_X$$

Where R_X is in k Ω , C_X is in pF, t is in ns or R_X is in k Ω , C_X is in μF , t is in ms.

4. The output pulse width for $R_X < 10 \text{ k}\Omega$ or $C_X < 1000 \text{ pF}$ should be determined from pulse width versus C_X or R_X graphs.

5. To obtain variable pulse width by remote trimming, the following circuit is recommended:

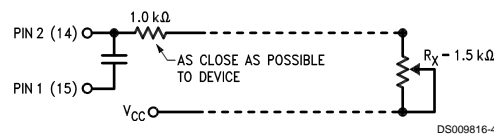

6. Under any operating condition, C_X and R_X (Min) must be kept as close to the circuit as possible to minimize stray capacitance and reduce noise pickup.

7. V_{CC} and ground wiring should conform to good high frequency standards so that switching transients on V_{CC} and ground leads do not cause interaction between one shots. Use of a 0.01 μF to 0.1 μF bypass capacitor between V_{CC} and ground located near the circuit is recommended.

Operation Notes (Continued)

TRIGGERING

1. The minimum negative pulse width into $\bar{I}0$ is 8.0 ns; the minimum positive pulse width into I1 is 12 ns.
2. Input signals to the 96LS02 exhibiting slow or noisy transitions can use either trigger as both are Schmitt triggers.
3. When non-retriggerable operation is required, i.e., when input triggers are to be ignored during quasi-stable state, input latching is used to inhibit retriggering.
4. An overriding active LOW level direct clear is provided on each multivibrator. By applying a LOW to the clear, any timing cycle can be terminated or any new cycle inhibited until the LOW reset input is removed. Trigger inputs will not produce spikes in the output when the reset is held LOW. A LOW-to-HIGH transition on \bar{C}_D will not trigger the 96LS02. If the \bar{C}_D input goes HIGH coincident with a trigger transition, the circuit will respond to the trigger.

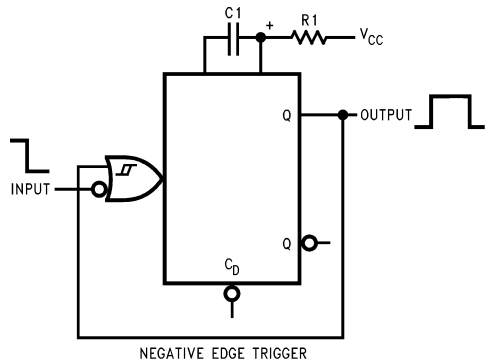

DS009816-5

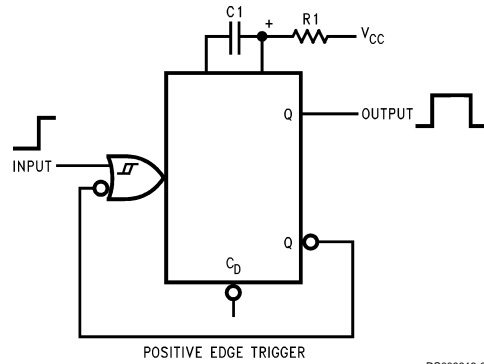

DS009816-6

Triggering Truth Table

Pin No.'s.			Operation
5(11)	4(12)	3(13)	
H→L	L	H	Trigger
H	L→H	H	Trigger
X	X	L	Reset

H = HIGH Voltage Level $\geq V_{IH}$
 L = LOW Voltage Level $\leq V_{IL}$
 X = Immaterial (either H or L)
 H→L = HIGH to LOW Voltage Level Transition
 L→H = LOW to HIGH Voltage Level Transition

Logic Symbol

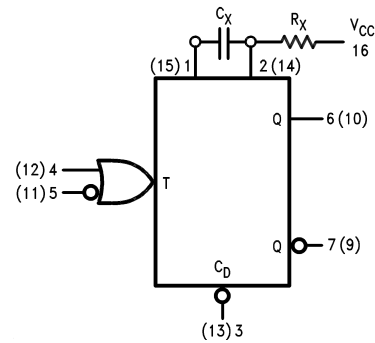

DS009816-2

V_{CC} = Pin 16
 GND = Pin 8

Logic Diagram

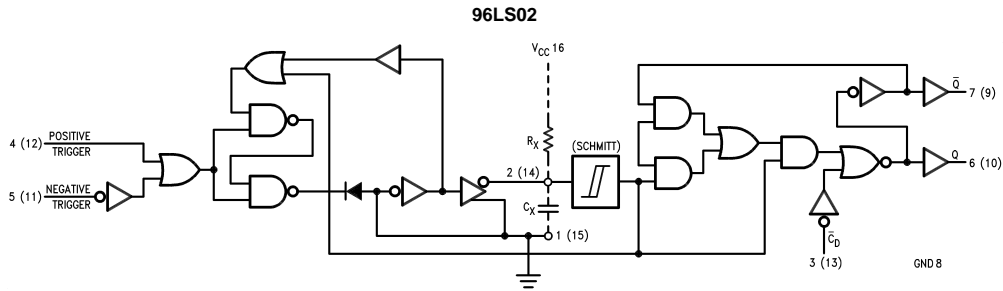

DS009816-3

Typical Performance Characteristics

Output t_w vs R_X and C_X

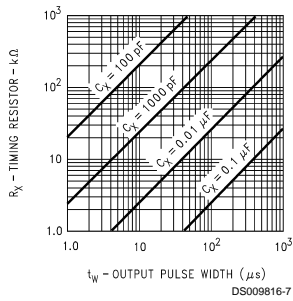

I1 Delay Time vs T_A

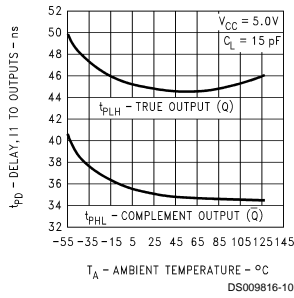

I0 Delay Time vs T_A

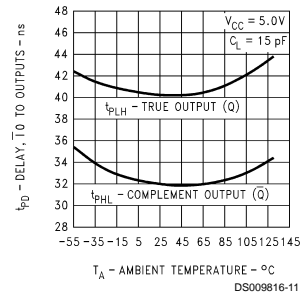

Output t_w vs T_A

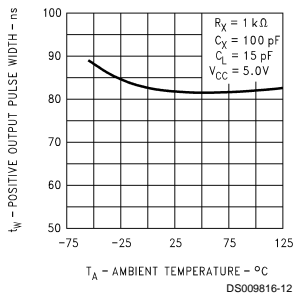

Normalized Δt_w vs T_A

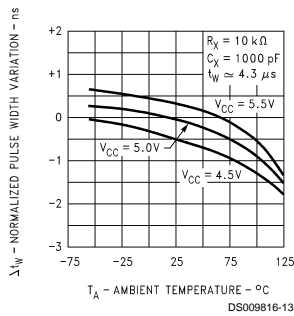

Pulse Width vs $R_X C_X$

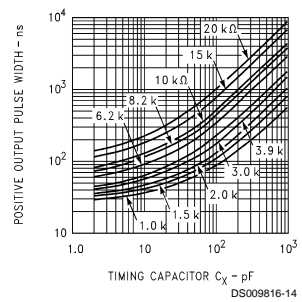

Typical Performance Characteristics (Continued)

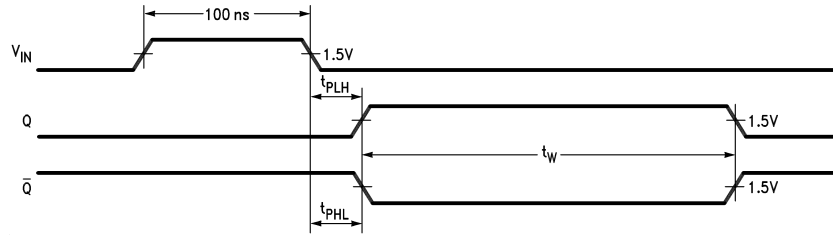

DS009816-8

Input Pulse
 $f \cong 100$ kHz
Amp $\cong 3.0$ V
Width $\cong 100$ ns
 $t_r = t_f \leq 5$ ns

FIGURE 1.



Physical Dimensions inches (millimeters) unless otherwise noted

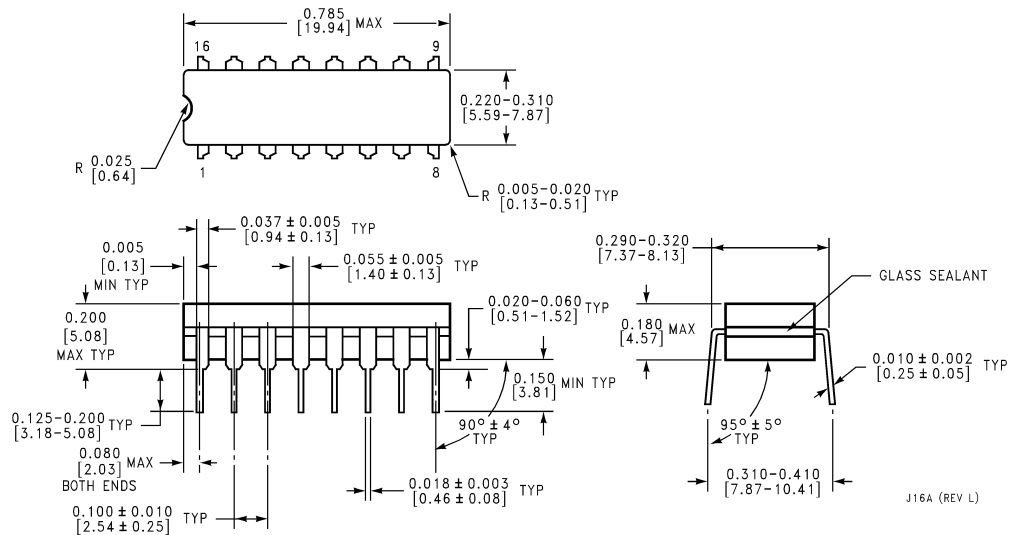

16-Lead Ceramic Dual-In-Line Package (J)
Order Number 96LS02DMQB
Package Number J16A

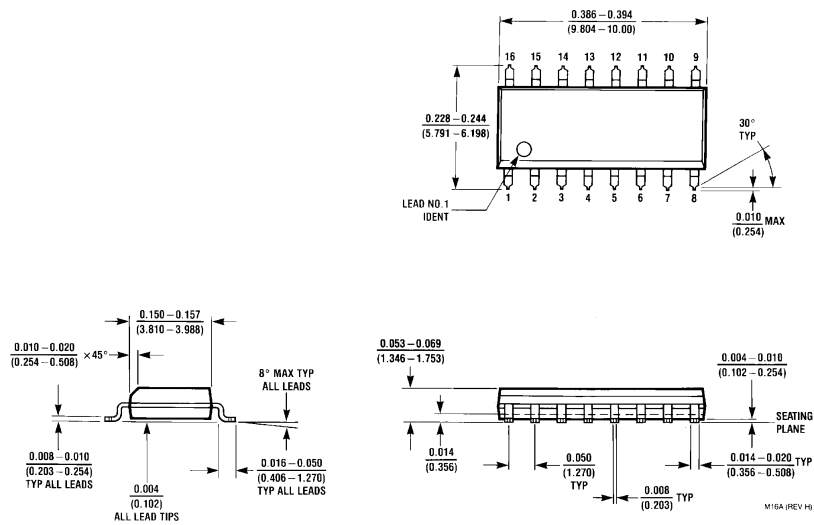

16-Lead Small Outline Molded Package (M)
Order Number DM96LS02M
Package Number M16A

Physical Dimensions inches (millimeters) unless otherwise noted (Continued)

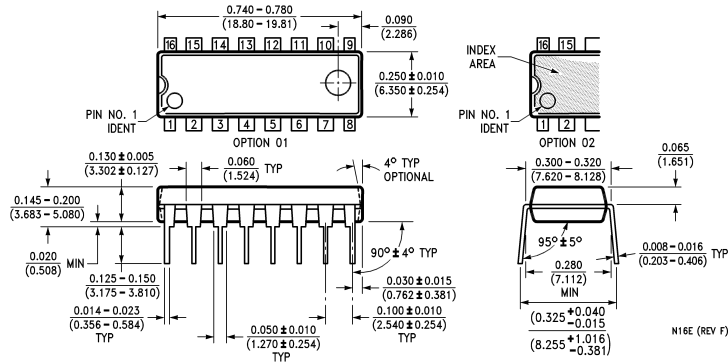

16-Lead Molded Dual-In-Line Package (N)
Order Number DM96LS02N
Package Number N16E

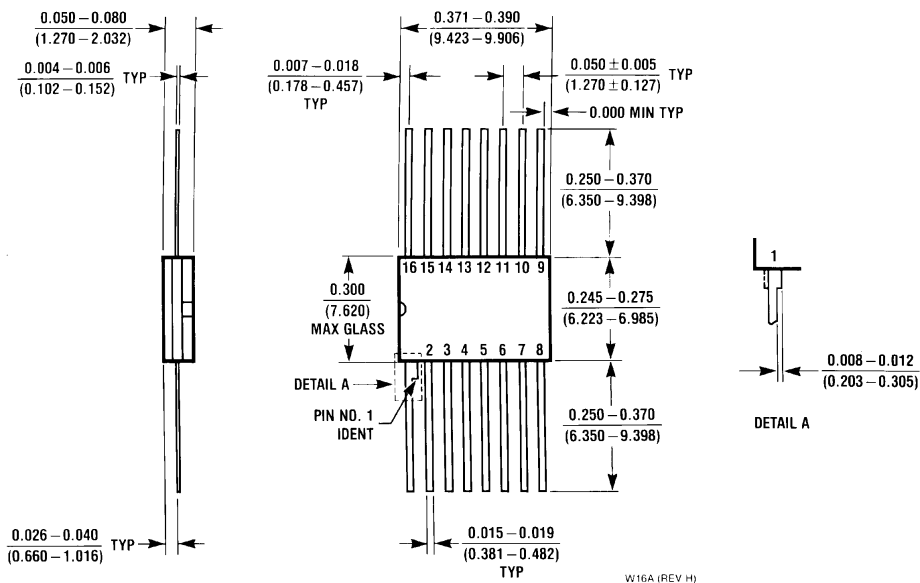

16-Lead Ceramic Flat Package (W)
Order Number 96LS02FMQB
Package Number W16A

LIFE SUPPORT POLICY

FAIRCHILD'S PRODUCTS ARE NOT AUTHORIZED FOR USE AS CRITICAL COMPONENTS IN LIFE SUPPORT DEVICES OR SYSTEMS WITHOUT THE EXPRESS WRITTEN APPROVAL OF THE PRESIDENT OF FAIRCHILD SEMICONDUCTOR CORPORATION. As used herein:

1. Life support devices or systems are devices or systems which, (a) are intended for surgical implant into the body, or (b) support or sustain life, and (c) whose failure to perform when properly used in accordance with instructions for use provided in the labeling, can be reasonably expected to result in a significant injury to the user.
2. A critical component in any component of a life support device or system whose failure to perform can be reasonably expected to cause the failure of the life support device or system, or to affect its safety or effectiveness.

Fairchild Semiconductor Corporation Americas
Customer Response Center
Tel: 1-888-522-5372

Fairchild Semiconductor Europe
Fax: +49 (0) 1 80-530 85 86
Email: europe.support@nsc.com
Deutsch Tel: +49 (0) 8 141-35-0
English Tel: +44 (0) 1 793-85-68-56
Italy Tel: +39 (0) 2 57 5631

Fairchild Semiconductor Hong Kong Ltd.
13th Floor, Straight Block,
Ocean Centre, 5 Canton Rd.
Tsimshatsui, Kowloon
Hong Kong
Tel: +852 2737-7200
Fax: +852 2314-0061

National Semiconductor Japan Ltd.
Tel: 81-3-5620-6175
Fax: 81-3-5620-6179

www.fairchildsemi.com