

DS75123 Dual Line Driver

General Description

The DS75123 is a monolithic dual line driver designed specifically to meet the I/O interface specifications for IBM System 360. It is compatible with standard TTL logic and supply voltage levels.

The low-impedance emitter-follower outputs of the DS75123 enable driving terminated low impedance lines. In addition the outputs are uncommitted allowing two or more drivers to drive the same line.

Output short-circuit protection is incorporated to turn off the output when the output voltage drops below approximately 1.5V.

Features

- Meet IBM System 360 I/O interface specifications for digital data transmission over 50Ω to 500Ω coaxial cable, strip line, or terminated pair transmission lines
- TTL compatible with single 5.0V supply
- 3.11V output at $I_{OH} = -59.3 \text{ mA}$
- Open emitter-follower output structure for party-line operation
- Short circuit protection
- AND-OR logic configuration
- Plug-in replacement for the SN75123 and the 8T23

Connection Diagram

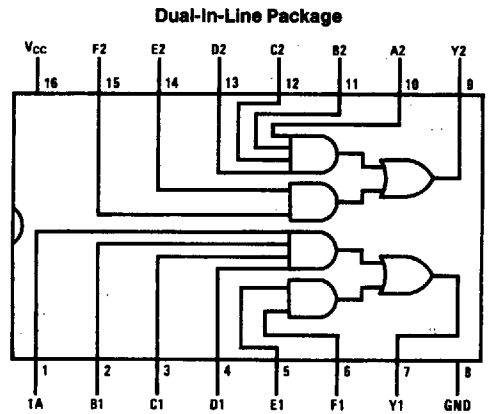

Top View

TL/F/5790-1

Order Number DS75123N
See NS Package Number N16A

AC Test Circuit and Switching Time Waveforms

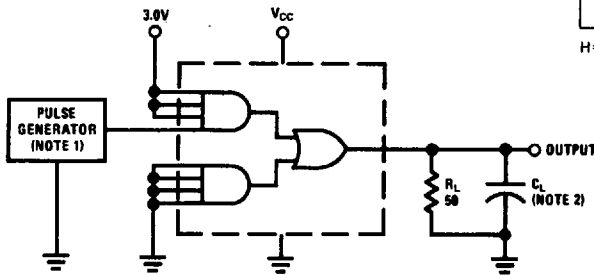

TL/F/5790-2

Note 1: The pulse generators have the following characteristics: $Z_{OUT} \approx 50\Omega$, $t_w = 200 \text{ ns}$, duty cycle = 50%.

Note 2: C_L includes probe and jig capacitance.

Typical Performance Characteristics

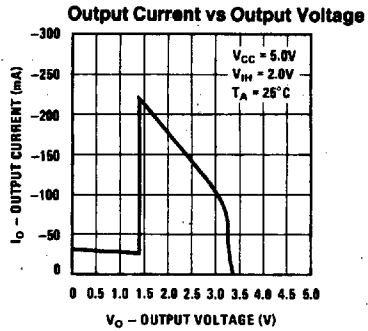

TL/F/5790-3

Truth Table

INPUTS						OUTPUT
A	B	C	D	E	F	Y
H	H	H	H	X	X	H
X	X	X	X	H	H	H
All Other Input Combinations						L

H=High level, L=Low level, X=Irrelevant

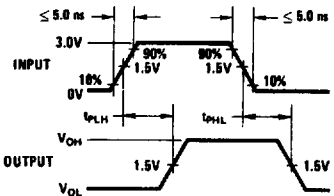

TL/F/5790-4

Absolute Maximum Ratings (Note 1)

If Military/Aerospace specified devices are required, please contact the National Semiconductor Sales Office/Distributors for availability and specifications.

Supply Voltage, V_{CC}	7.0V
Input Voltage	5.5V
Output Voltage	7.0V
Maximum Power Dissipation* at 25°C	
Molded Package	1280 mW
Operating Free-Air Temperature Range	0°C to +75°C
Storage Temperature Range	-65°C to +150°C
Lead Temperature (Soldering, 4 seconds)	260°C

*Derate molded package 10.2 mW/°C above 25°C.

Operating Conditions

	Min	Max	Units
Supply Voltage, V_{CC}	4.75	5.25	V
High Level Output Current, I_{OH}		-100	mA
Temperature, T_A	0	+75	°C

Electrical Characteristics (Notes 2 and 3)

Symbol	Parameter	Conditions	Min	Typ	Max	Units
V_{IH}	High Level Input Voltage		2.0			V
V_{IL}	Low Level Input Voltage				0.8	V
V_I	Input Clamp Voltage	$V_{CC} = 5.0V, I_I = -12\text{ mA}$			-1.5	V
I_I	Input Current at Max Input Voltage	$V_{CC} = 5.25V, V_{IN} = 5.5V$			1	mA
V_{OH}	High Level Output Voltage	$V_{CC} = 5.0V, V_{IH} = 2.0V, I_{OH} = -59.3\text{ mA}$, (Note 4)	$T_A = 25^\circ\text{C}$ 3.11			V
			$T_A = 0^\circ\text{C to } +75^\circ\text{C}$ 2.9			V
I_{OH}	High Level Output Current	$V_{CC} = 5.0V, V_{IH} = 4.5V, T_A = 25^\circ\text{C}, V_{OH} = 2.0V$, (Note 4)	-100		-250	mA
V_{OL}	Low Level Output Voltage	$V_{IL} = 0.8V, I_{OL} = -240\text{ }\mu\text{A}$, (Note 4)			0.15	V
$I_{O(OFF)}$	Off State Output Current	$V_{CC} = 0, V_O = 3.0V$			40	μA
I_{IH}	High Level Input Current	$V_I = 4.5V$			40	μA
I_{IL}	Low Level Input Current	$V_I = 0.4V$	-0.1		-1.6	mA
I_{OS}	Short Circuit Output Current	$V_{CC} = 5.0V, T_A = 25^\circ\text{C}$			-30	mA
I_{CCH}	Supply Current, Outputs High	$V_{CC} = 5.25V$, All Inputs at 2.0V, Outputs Open			28	mA
I_{CCL}	Supply Current, Outputs Low	$V_{CC} = 5.25V$, All Inputs at 0.8V, Outputs Open			60	mA

Switching Characteristics $V_{CC} = 5.0V, T_A = 25^\circ\text{C}$

Symbol	Parameter	Conditions	Min	Typ	Max	Units	
t_{PLH}	Propagation Delay Time, Low-to-High Level Output	$R_L = 50\Omega$, (See AC Test Circuit and Switching Time Waveforms)	$C_L = 15\text{ pF}$		12	20	ns
			$C_L = 100\text{ pF}$		20	35	ns
t_{PHL}	Propagation Delay Time, High-to-Low Level Output	$R_L = 50\Omega$, (See AC Test Circuit and Switching Time Waveforms)	$C_L = 15\text{ pF}$		12	20	ns
			$C_L = 100\text{ pF}$		15	25	ns

Note 1: "Absolute Maximum Ratings" are those values beyond which the safety of the device cannot be guaranteed. Except for "Operating Temperature Range" they are not meant to imply that the devices should be operated at these limits. The table of "Electrical Characteristics" provides conditions for actual device operation.

Note 2: All currents into device pins are shown as positive, currents out of device pins shown as negative, all voltage values are referenced with respect to network ground terminal, unless otherwise noted. All values shown as max or min on absolute value basis.

Note 3: Min/max limits apply across the guaranteed operating temperature range of 0°C to +75°C for DS75123, unless otherwise specified. Typicals are for $V_{CC} = 5.0V, T_A = 25^\circ\text{C}$. Positive current is defined as current into the referenced pin.

Note 4: The output voltage and current limits are guaranteed for any appropriate combination of high and low inputs specified by the truth table for the desired output.