

DS90LV004

4-Channel LVDS Buffer/Repeater with Pre-Emphasis

General Description

The DS90LV004 is a four channel 1.5 Gbps LVDS buffer/repeater. High speed data paths and flow-through pinout minimize internal device jitter and simplify board layout, while configurable pre-emphasis overcomes ISI jitter effects from lossy backplanes and cables. The differential inputs interface to LVDS, and Bus LVDS signals such as those on National's 10-, 16-, and 18-bit Bus LVDS SerDes, as well as CML and LVPECL. The differential inputs are internally terminated with a 100Ω resistor to improve performance and minimize board space. The repeater function is especially useful for boosting signals for longer distance transmission over lossy cables and backplanes.

Features

- 1.5 Gbps data rate per channel
- Configurable pre-emphasis drives lossy backplanes and cables
- Low output skew and jitter
- Hot plug protection
- LVDS/CML/LVPECL compatible input, LVDS output
- On-chip 100Ω input termination
- 15 kV ESD protection
- Single 3.3V supply
- Very low power consumption
- Industrial -40 to +85°C temperature range
- Small TQFP Package Footprint
- Evaluation Kit Available
- See SCAN90004 for JTAG-enabled version

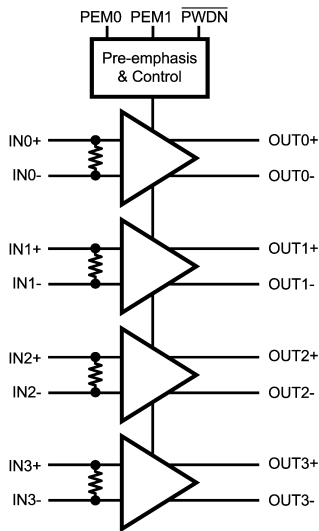

DS90LV004 Block Diagram 20146601

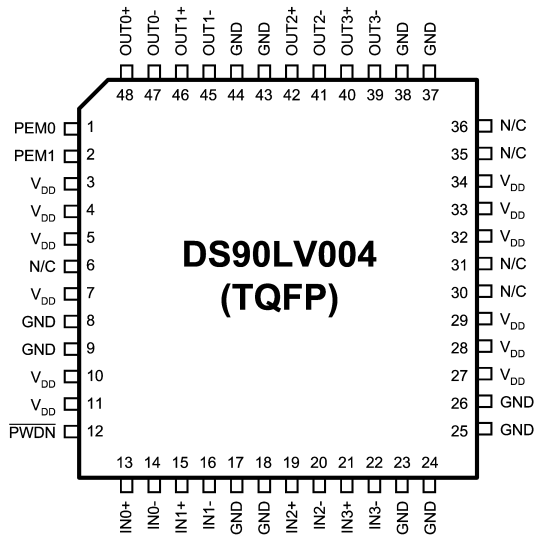

Pinout - Top View 20146602

DS90LV004 4-Channel LVDS Buffer/Repeater with Pre-Emphasis

Pin Descriptions

Pin Name	TQFP Pin Number	I/O, Type	Description
DIFFERENTIAL INPUTS			
IN0+	13	I, LVDS	Channel 0 inverting and non-inverting differential inputs.
IN0-	14		
IN1+	15	I, LVDS	Channel 1 inverting and non-inverting differential inputs.
IN1-	16		
IN2+	19	I, LVDS	Channel 2 inverting and non-inverting differential inputs.
IN2-	20		
IN3+	21	I, LVDS	Channel 3 inverting and non-inverting differential inputs.
IN3-	22		
DIFFERENTIAL OUTPUTS			
OUT0+	48	O, LVDS	Channel 0 inverting and non-inverting differential outputs. (Note 1)
OUT0-	47		
OUT1+	46	O, LVDS	Channel 1 inverting and non-inverting differential outputs. (Note 1)
OUT1-	45		
OUT2+	42	O, LVDS	Channel 2 inverting and non-inverting differential outputs. (Note 1)
OUT2-	41		
OUT3+	40	O, LVDS	Channel 3 inverting and non-inverting differential outputs. (Note 1)
OUT3-	39		
DIGITAL CONTROL INTERFACE			
PWDN	12	I, LVTTTL	A logic low at $\overline{\text{PWDN}}$ activates the hardware power down mode.
PEM0	1	I, LVTTTL	Pre-emphasis Control Inputs (affects all Channels)
PEM1	2		
POWER			
V _{DD}	3, 4, 5, 7, 10, 11, 27, 28, 29, 32, 33, 34	I, Power	V _{DD} = 3.3V, ±5%
GND	8, 9, 17, 18, 23, 24, 25, 26, 37, 38, 43, 44	I, Power	Ground
N/C	6, 30, 31, 35, 36		No Connect

Note 1: The LVDS outputs do not support a multidrop (BLVDS) environment. The LVDS output characteristics of the DS90LV004 device have been optimized for point-to-point backplane and cable applications.

Absolute Maximum Ratings (Note 2)

EIAJ, 0Ω, 200pF

250V

Supply Voltage (V_{DD})	-0.3V to +4.0V
CMOS Input Voltage	-0.3V to ($V_{DD}+0.3V$)
LVDS Receiver Input Voltage	-0.3V to ($V_{DD}+0.3V$)
LVDS Driver Output Voltage	-0.3V to ($V_{DD}+0.3V$)
LVDS Output Short Circuit Current	+40 mA
Junction Temperature	+150°C
Storage Temperature	-65°C to +150°C
Lead Temperature (Solder, 4sec)	260°C
Max Pkg Power Capacity @ 25°C	1.64W
Thermal Resistance (θ_{JA})	76°C/W
Package Derating above +25°C	13.2mW/°C
ESD Last Passing Voltage	
HBM, 1.5kΩ, 100pF	15 kV

Recommended Operating Conditions

Supply Voltage (V_{CC})	3.15V to 3.45V
Input Voltage (V_I) (Note 3)	0V to V_{CC}
Output Voltage (V_O)	0V to V_{CC}
Operating Temperature (T_A)	
Industrial	-40°C to +85°C

Note 2: Absolute maximum ratings are those values beyond which damage to the device may occur. The databook specifications should be met, without exception, to ensure that the system design is reliable over its power supply, temperature, and output/input loading variables. National does not recommend operation of products outside of recommended operation conditions.

Note 3: V_{ID} max < 2.4V

Electrical Characteristics

Over recommended operating supply and temperature ranges unless other specified.

Symbol	Parameter	Conditions	Min	Typ (Note 4)	Max	Units
LVTTL DC SPECIFICATIONS ($\overline{P}WDN$, $PEM0$, $PEM1$)						
V_{IH}	High Level Input Voltage		2.0		V_{DD}	V
V_{IL}	Low Level Input Voltage		GND		0.8	V
I_{IH}	High Level Input Current	$V_{IN} = V_{DD} = V_{DDMAX}$	-10		+10	μA
I_{IL}	Low Level Input Current	$V_{IN} = V_{SS}$, $V_{DD} = V_{DDMAX}$	-10		+10	μA
C_{IN1}	Input Capacitance	Any Digital Input Pin to V_{SS}		3.5		pF
V_{CL}	Input Clamp Voltage	$I_{CL} = -18$ mA	-1.5	-0.8		V
LVDS INPUT DC SPECIFICATIONS ($INn\pm$)						
V_{TH}	Differential Input High Threshold (Note 5)	$V_{CM} = 0.8V$ to $3.4V$, $V_{DD} = 3.45V$		0	50	mV
V_{TL}	Differential Input Low Threshold (Note 5)	$V_{CM} = 0.8V$ to $3.4V$, $V_{DD} = 3.45V$	-50	0		mV
V_{ID}	Differential Input Voltage	$V_{CM} = 0.8V$ to $3.4V$, $V_{DD} = 3.45V$	100		2400	mV
V_{CMR}	Common Mode Voltage Range	$V_{ID} = 150$ mV, $V_{DD} = 3.45V$	0.05		3.40	V
C_{IN2}	Input Capacitance	$IN+$ or $IN-$ to V_{SS}		3.5		pF
I_{IN}	Input Current	$V_{IN} = 3.45V$, $V_{DD} = V_{DDMAX}$	-10		+10	μA
		$V_{IN} = 0V$, $V_{DD} = V_{DDMAX}$	-10		+10	μA

Electrical Characteristics (Continued)

Over recommended operating supply and temperature ranges unless other specified.

Symbol	Parameter	Conditions	Min	Typ (Note 4)	Max	Units
LVDS OUTPUT DC SPECIFICATIONS (OUT_{n±})						
V _{OD}	Differential Output Voltage, 0% Pre-emphasis (Note 5)	R _L = 100Ω between OUT+ and OUT-	250	500	600	mV
ΔV _{OD}	Change in V _{OD} between Complementary States		-35		35	mV
V _{OS}	Offset Voltage (Note 6)		1.05	1.18	1.475	V
ΔV _{OS}	Change in V _{OS} between Complementary States		-35		35	mV
I _{OS}	Output Short Circuit Current	OUT+ or OUT- Short to GND		-60	-90	mA
C _{OUT2}	Output Capacitance	OUT+ or OUT- to GND when TRI-STATE		5.5		pF
SUPPLY CURRENT (Static)						
I _{CC}	Supply Current	All inputs and outputs enabled and active, terminated with differential load of 100Ω between OUT+ and OUT-.		117	140	mA
I _{CCZ}	Supply Current - Power Down Mode	PWDN = L		2.7	6	mA
SWITCHING CHARACTERISTICS—LVDS OUTPUTS						
t _{LHT}	Differential Low to High Transition Time	Use an alternating 1 and 0 pattern at 200 Mbps, measure between 20% and 80% of V _{OD} .		210	300	ps
t _{HLT}	Differential High to Low Transition Time			210	300	ps
t _{PLHD}	Differential Low to High Propagation Delay	Use an alternating 1 and 0 pattern at 200 Mbps, measure at 50% V _{OD} between input to output.		2.0	3.2	ns
t _{PHLD}	Differential High to Low Propagation Delay			2.0	3.2	ns
t _{SKD1}	Pulse Skew	t _{PLHD} - t _{PHLD}		25	80	ps
t _{SKCC}	Output Channel to Channel Skew	Difference in propagation delay (t _{PLHD} or t _{PHLD}) among all output channels.		50	125	ps
t _{JIT}	Jitter (0% Pre-emphasis) (Note 7)	RJ - Alternating 1 and 0 at 750 MHz (Note 8)		1.1	1.5	psrms
		DJ - K28.5 Pattern, 1.5 Gbps (Note 9)		43	62	psp-p
		TJ - PRBS 2 ²³ -1 Pattern, 1.5 Gbps (Note 10)		35	85	psp-p
t _{ON}	LVDS Output Enable Time	Time from $\overline{\text{PWDN}}$ to OUT± change from TRI-STATE to active.			300	ns
t _{OFF}	LVDS Output Disable Time	Time from $\overline{\text{PWDN}}$ to OUT± change from active to TRI-STATE.			12	ns

Note 4: Typical parameters are measured at V_{DD} = 3.3V, T_A = 25°C. They are for reference purposes, and are not production-tested.

Note 5: Differential output voltage V_{OD} is defined as ABS(OUT+ - OUT-). Differential input voltage V_{ID} is defined as ABS(IN+ - IN-).

Note 6: Output offset voltage V_{OS} is defined as the average of the LVDS single-ended output voltages at logic high and logic low states.

Note 7: Jitter is not production tested, but guaranteed through characterization on a sample basis.

Note 8: Random Jitter, or RJ, is measured RMS with a histogram including 1500 histogram window hits. The input voltage = V_{ID} = 500mV, 50% duty cycle at 750MHz, t_r = t_f = 50ps (20% to 80%).

Note 9: Deterministic Jitter, or DJ, is measured to a histogram mean with a sample size of 350 hits. The input voltage = V_{ID} = 500mV, K28.5 pattern at 1.5 Gbps, t_r = t_f = 50ps (20% to 80%). The K28.5 pattern is repeating bit streams of (0011111010 1100000101).

Note 10: Total Jitter, or TJ, is measured peak to peak with a histogram including 3500 window hits. Stimulus and fixture Jitter has been subtracted. The input voltage = V_{ID} = 500mV, 2²³-1 PRBS pattern at 1.5 Gbps, t_r = t_f = 50ps (20% to 80%).

Feature Descriptions

OUTPUT CHARACTERISTICS

The output characteristics of the DS90LV004 have been optimized for point-to-point backplane and cable applications, and are not intended for multipoint or multidrop signaling.

POWERDOWN MODE

The $\overline{\text{PWDN}}$ input activates a hardware powerdown mode. When the powerdown mode is active ($\text{PWDN}=\text{L}$), all input and output buffers and internal bias circuitry are powered off and disabled. Outputs are tri-stated in powerdown mode. When exiting powerdown mode, there is a delay associated with turning on bandgap references and input/output buffer circuits as indicated in the LVDS Output Switching Characteristics

PRE-EMPHASIS

Pre-emphasis dramatically reduces ISI jitter from long or lossy transmission media. Two pins are used to select the pre-emphasis level for all outputs: off, low, medium, or high.

Pre-emphasis Control Selection Table

PEM1	PEM0	Pre-Emphasis
0	0	Off
0	1	Low
1	0	Medium
1	1	High

INPUT FAILSAFE BIASING

External pull up and pull down resistors may be used to provide enough of an offset to enable an input failsafe under open-circuit conditions. This configuration ties the positive LVDS input pin to V_{DD} thru a pull up resistor and the negative LVDS input pin is tied to GND by a pull down resistor. The pull up and pull down resistors should be in the $5k\Omega$ to $15k\Omega$ range to minimize loading and waveform distortion to the driver. The common-mode bias point ideally should be set to approximately 1.2V (less than 1.75V) to be compatible with the internal circuitry. Please refer to application note AN-1194 "Failsafe Biasing of LVDS Interfaces" for more information.

Typical Performance Characteristics

Power Supply Current vs. Bit Data Rate

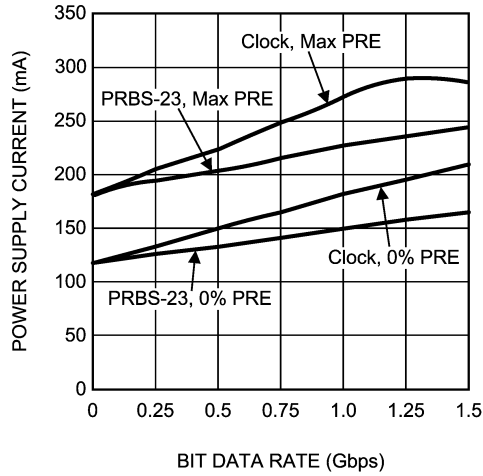

20146641
 Dynamic power supply current was measured while running a clock or PRBS $2^{23}-1$ pattern with all 4 channels active. $V_{CC} = 3.3V$, $T_A = +25^\circ C$, $V_{ID} = 0.5V$, $V_{CM} = 1.2V$

Total Jitter (T_J) vs. Bit Data Rate

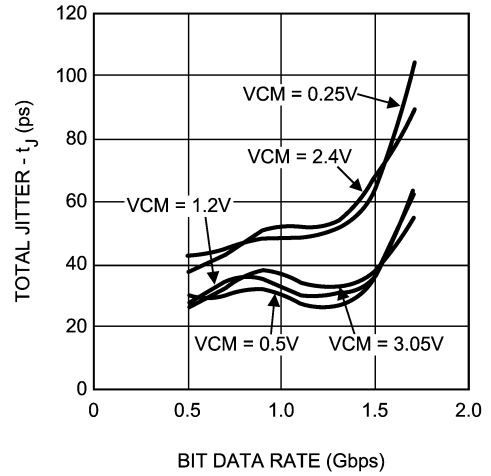

20146642
 Total Jitter measured at 0V differential while running a PRBS $2^{23}-1$ pattern with a single channel active. $V_{CC} = 3.3V$, $T_A = +25^\circ C$, $V_{ID} = 0.5V$, 0% Pre-emphasis

Total Jitter (T_J) vs. Temperature

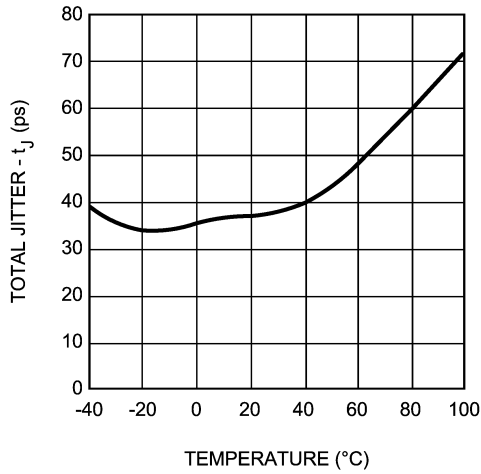

20146643
 Total Jitter measured at 0V differential while running a PRBS $2^{23}-1$ pattern with a single channel active. $V_{CC} = 3.3V$, $V_{ID} = 0.5V$, $V_{CM} = 1.2V$, 1.5 Gbps data rate, 0% Pre-emphasis

Positive Edge Transition vs. Pre-emphasis Level

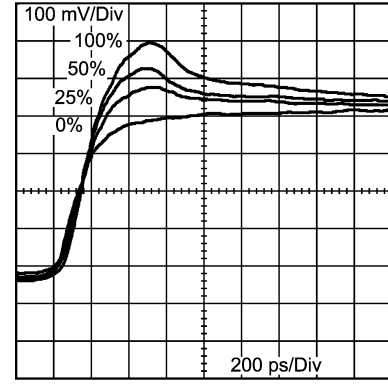

20146644

FIGURE 1. Typical Performance Characteristics of the DS90LV004

Physical Dimensions inches (millimeters) unless otherwise noted

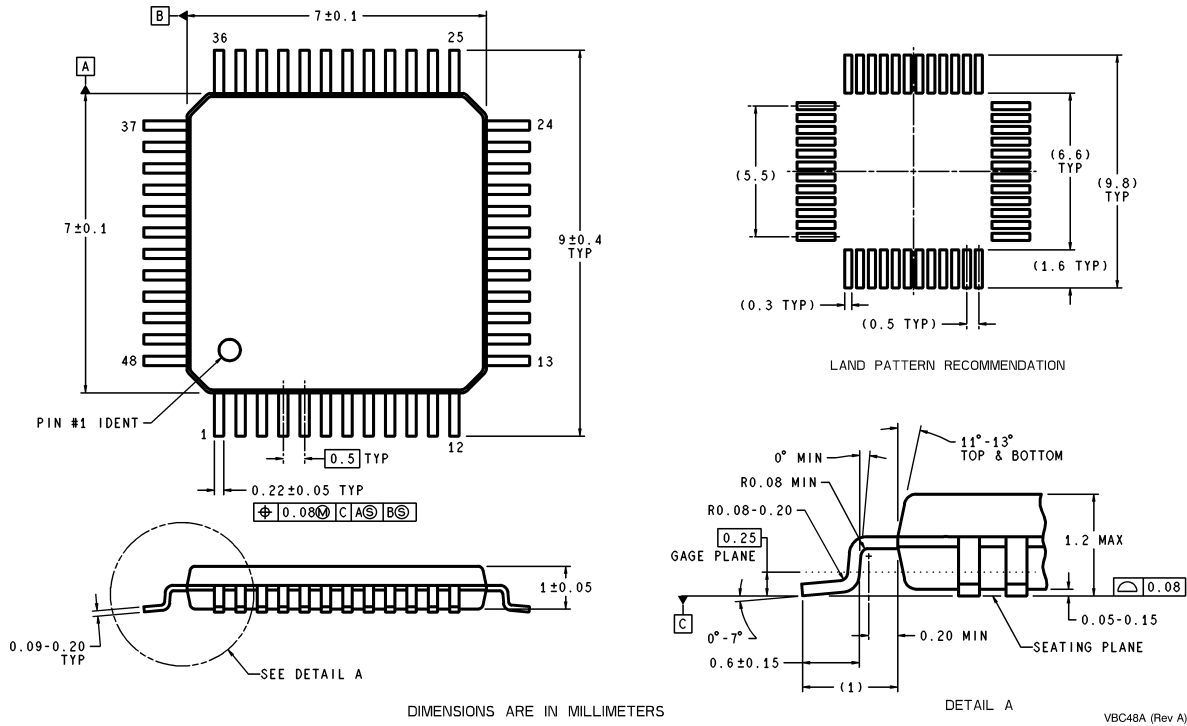

48-TQFP
NS Package Number VBC48a
Order Number DS90LV004TVS (250 piece Tray)

National does not assume any responsibility for use of any circuitry described, no circuit patent licenses are implied and National reserves the right at any time without notice to change said circuitry and specifications.
 For the most current product information visit us at www.national.com.

LIFE SUPPORT POLICY

NATIONAL'S PRODUCTS ARE NOT AUTHORIZED FOR USE AS CRITICAL COMPONENTS IN LIFE SUPPORT DEVICES OR SYSTEMS WITHOUT THE EXPRESS WRITTEN APPROVAL OF THE PRESIDENT AND GENERAL COUNSEL OF NATIONAL SEMICONDUCTOR CORPORATION. As used herein:

1. Life support devices or systems are devices or systems which, (a) are intended for surgical implant into the body, or (b) support or sustain life, and whose failure to perform when properly used in accordance with instructions for use provided in the labeling, can be reasonably expected to result in a significant injury to the user.
2. A critical component is any component of a life support device or system whose failure to perform can be reasonably expected to cause the failure of the life support device or system, or to affect its safety or effectiveness.

BANNED SUBSTANCE COMPLIANCE

National Semiconductor manufactures products and uses packing materials that meet the provisions of the Customer Products Stewardship Specification (CSP-9-111C2) and the Banned Substances and Materials of Interest Specification (CSP-9-111S2) and contain no "Banned Substances" as defined in CSP-9-111S2.
 Leadfree products are RoHS compliant.



National Semiconductor
Americas Customer
Support Center
 Email: new.feedback@nsc.com
 Tel: 1-800-272-9959

National Semiconductor
Europe Customer Support Center
 Fax: +49 (0) 180-530 85 86
 Email: europe.support@nsc.com
 Deutsch Tel: +49 (0) 69 9508 6208
 English Tel: +44 (0) 870 24 0 2171
 Français Tel: +33 (0) 1 41 91 8790

National Semiconductor
Asia Pacific Customer
Support Center
 Email: ap.support@nsc.com

National Semiconductor
Japan Customer Support Center
 Fax: 81-3-5639-7507
 Email: jpn.feedback@nsc.com
 Tel: 81-3-5639-7560