

# SPECIFICATION

Device Name : Current Mode PWM Controller

Type Name : FA13844P

Spec. No. : \_\_\_\_\_

This material and the information herein is the property of Fuji Electric Co., Ltd. They shall be neither reproduced, copied, lent, or disclosed in any way whatsoever for the use of any third party, nor used for the manufacturing purposes without the express written consent of Fuji Electric Co., Ltd.

Fuji Electric Co., Ltd.  
Matsumoto Factory

	DATE	NAME	APPROVED	Fuji Electric Co., Ltd.		
DRAWN				DWG. NO.		
CHECKED						

1. Type Name            FA13844P
2. Function             Current Mode PWM Controller
3. Process              CMOS IC
4. Outline               DIP-8 (8pin plastic mold dual in-line package)
5. Block Diagram

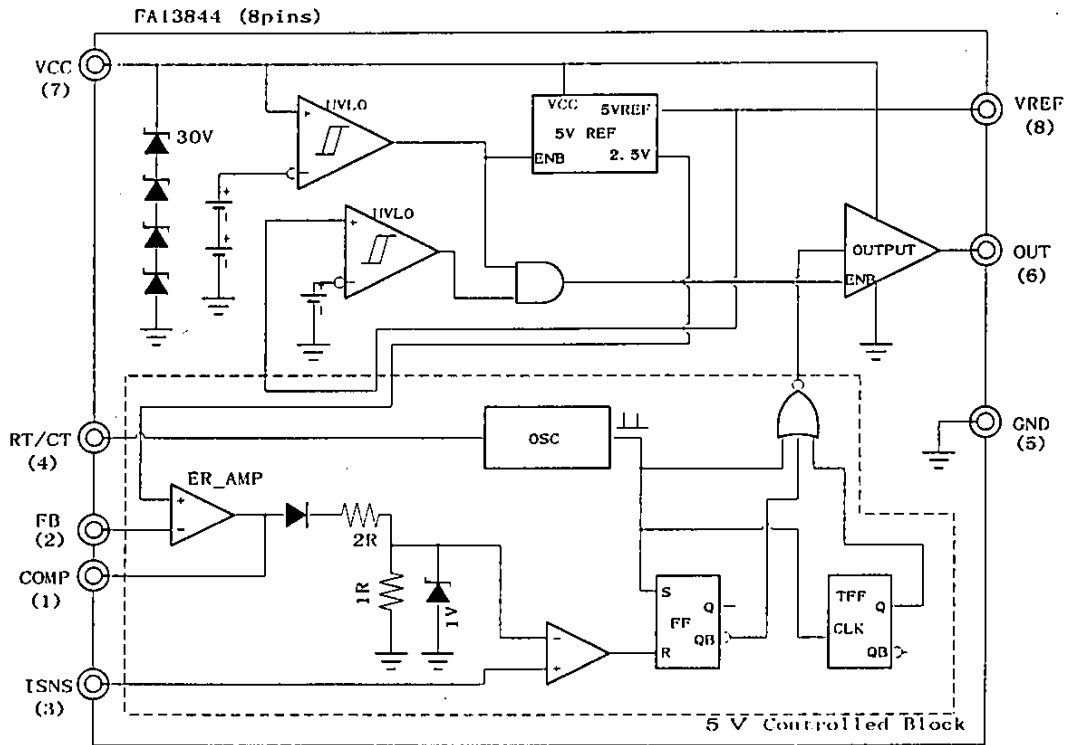

This material and the information herein is the property of Fuji Electric Co., Ltd. They shall be neither reproduced, copied, lent, or disclosed in any way whatsoever for the use of any third party, nor used for the manufacturing purposes without the express written consent of Fuji Electric Co., Ltd.

#### 6. Pin Assignment

Pin No.	Pin Name	Pin Function
1	COMP	Compensation
2	FB	Feedback (Input)
3	ISNS	Current Sense (Input)
4	RT/CT	Oscillator control
5	GND	Ground
6	OUT	Output
7	VCC	Power Supply
8	VREF	5V Reference Output

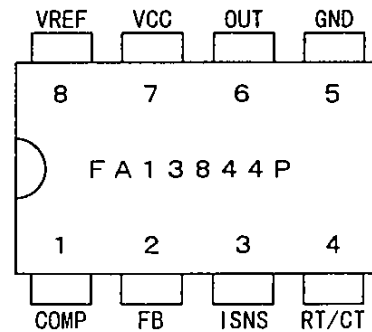

## 7. ABSOLUTE MAXIMUM RATINGS

Parameter	Conditions	Ratings	Units
Supply Voltage	Low Impedance Source	28	V
	Zener Clamp (at $I_{CC} < 10\text{mA}$ )	Self Limiting	V
Zener Current		10	mA
Output Peak Current	Pch Source Current	400	mA
	Nch Sink Current	1	A
Analog Input Voltage	FB,ISNS	-0.3 ~ 5.3	V
Error-amp Sink Current		10	mA
Power Dissipation	at $T_a < 50^\circ\text{C}$ (DIP-8)	800	mW
Package Thermal Resistance $\theta_{j-a}$	between Junction and Ambient	125	$^\circ\text{C}/\text{W}$
Operating Junction Temperature		150	$^\circ\text{C}$
Operating Ambient Temperature		-25 ~ 85	$^\circ\text{C}$
Storage Temperature		-40 ~ 150	$^\circ\text{C}$

## 8. RECOMMENDED OPERATING CONDITIONS

Parameter	MIN.	MAX.	Units
Supply Voltage	10	25	V
RT Resistor	2.0	100	k $\Omega$
CT Capacitor	0.47	10	nF
Operating Frequency	10	500	kHz

This material and the information herein is the property of Fuji Electric Co., Ltd. They shall be neither reproduced, copied, lent, or disclosed in any way whatsoever for the use of any third party, nor used for the manufacturing purposes without the express written consent of Fuji Electric Co., Ltd.

Fuji Electric Co., Ltd.

DWG.NO.

H04-004-03

## 9. ELECTRICAL SPECIFICATIONS

( Unless otherwise standard, these specifications apply for VCC=15V, RT=10k, CT=3.3nF, Ta=25°C )

### Reference Section

Parameter	Conditions	MIN.	TYP.	MAX.	Units
Output Voltage	Tj=25°C, IL=1mA	4.75	5.00	5.25	V
Line Regulation	VCC=10~25V		±3	±20	mV
Load Regulation	IL=0~20mA		±3	±25	mV
Temp. Stability	Ta=-25~85°C		±0.3		mV/°C
Output Short Current	Tj=25°C		60		mA

### Oscillator Section

Parameter	Conditions	MIN.	TYP.	MAX.	Units
Frequency	Tj=25°C	49	52	55	kHz
	Tj=-25~85°C	47		57	kHz
Voltage Stability	VCC=10~25V		±0.25	±1	%
Temp. Stability	Ta=-25~85°C		-0.07		%/°C
Amplitude	Tj=25°C		1.6		V
Discharge Current	Tj=25°C		8.4		mA

### Error Amp Section

Parameter	Conditions	MIN.	TYP.	MAX.	Units
Input Voltage	COMP=2.5V, Tj=25°C	2.4	2.5	2.6	V
Input Leak Current				±2	µA
Open-loop Gain		65	72		dB
Unity Gain Bandwidth		0.7	1		MHz
Output Source Current	FB=2.3V, COMP=0V	-0.8	-1.0		mA
Output Sink Current	FB=2.7V, COMP=1V	2	15		mA
Output Voltage	FB=2.3V RL=15k to GND	4.0	4.5		V
	FB=2.7V RL=15k to VREF		80	500	mV

### Current Sense Section

Parameter	Conditions	MIN.	TYP.	MAX.	Units
Gain	Tj=25°C	2.85	3	3.15	V/V
Maximum Input Signal	FB=0V	0.9	1.0	1.1	V
Input Bias Current			-1	-5	µA
Delay to Output	Tj=25°C, ISNS→OUT		150	300	ns

This material and the information herein is the property of Fuji Electric Co., Ltd. They shall be neither reproduced, copied, lent, or disclosed in any way whatsoever for the use of any third party, nor used for the manufacturing purposes without the express written consent of Fuji Electric Co., Ltd.

Fuji Electric Co., Ltd.

DWG. NO.

H04-004-03

This material and the information herein is the property of Fuji Electric Co., Ltd. They shall be neither reproduced, copied, lent, or disclosed in any way whatsoever for the use of any third party, nor used for the manufacturing purposes without the express written consent of Fuji Electric Co., Ltd.

### Output Section

Parameter	Conditions	MIN.	TYP.	MAX.	Units
Output High Level	I <sub>source</sub> =-20mA	14.5	14.75		V
	I <sub>source</sub> =-100mA	12	13.5		V
Output Low Level	I <sub>sink</sub> =20mA		0.15	0.3	V
	I <sub>sink</sub> =200mA		1.5	3	V
Rise Time	CL=1nF, T <sub>j</sub> =25°C		40	150	ns
Fall Time	CL=1nF, T <sub>j</sub> =25°C		20	150	ns

### Under-Voltage Lockout Section

Parameter	Conditions	MIN.	TYP.	MAX.	Units
Start Threshold		15.5	16.5	17.5	V
Min. Operating Voltage		8	9	10	V
Hysteresis			7.5		V

### PWM Section

Parameter	Conditions	MIN.	TYP.	MAX.	Units
Maximum Duty Cycle		47	48	50	%
Minimum Duty Cycle	FB=5V, COMP=open			0	%

### Overall Section

Parameter	Conditions	MIN.	TYP.	MAX.	Units
Standby Current	VCC=14V			2	uA
Start-up Current	VCC=Start Threshold		12	30	uA
Operating Current			3	5	mA
Zener Voltage ( VCC )	ICC=5mA	28	30	34	V

**Fuji Electric Co., Ltd.**

DWG. NO.

H04-004-03

11. Outline Diagram (DIP-8 pins)

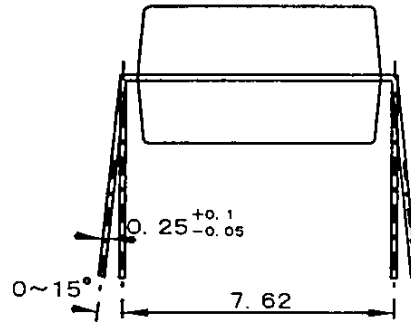
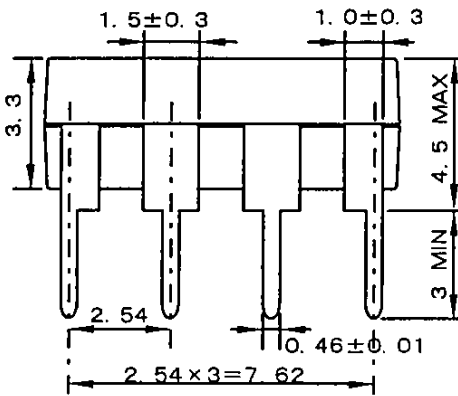
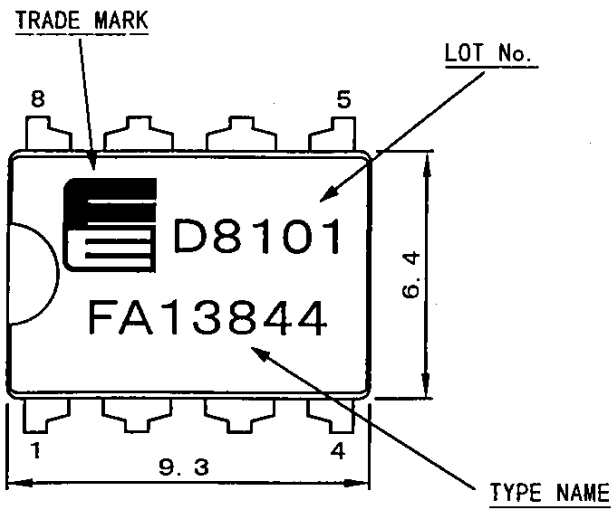

UNIT: mm

This material and the information herein is the property of Fuji Electric Co., Ltd. They shall be neither reproduced, copied, lent, or disclosed in any way whatsoever for the use of any third party, nor used for the manufacturing purposes without the express written consent of Fuji Electric Co., Ltd.

Contents of Lot No.

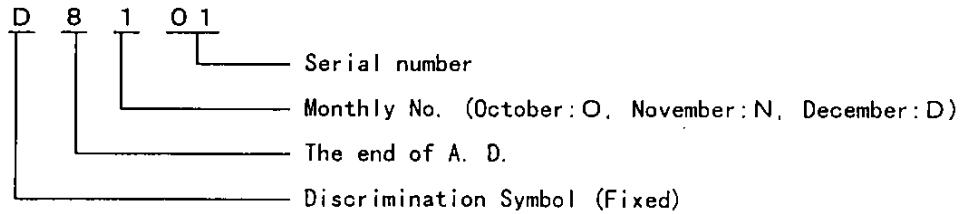

Fuji Electric Co., Ltd.

DWG. NO.
