

DIODE MODULE (F.R.D.)

FRS150BA50

TOP



UL;E76102 (M)

FRS150BA50 is a high speed (fast recovery) isolated diode module designed for high power switching application. FRS150BA50 is suitable for high frequency application requiring low loss and high speed control.

- High Speed $t_{rr} \leq 200\text{ns}$
- $I_F (AV)$ 150A
- Isolated Mounting base.
- High Surge Capability

(Applications)

Inverter Welding Power Supply
 Power Supply for Telecommunication
 Various Switching Power Supply.

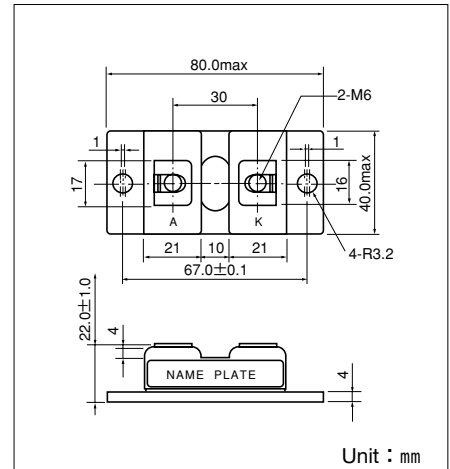
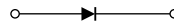

Maximum Ratings

($T_j=25^\circ\text{C}$ unless otherwise specified)

Symbol	Item	Ratings		Unit
		FRS150BA50		
V_{RRM}	Repetitive Peak Reverse Voltage	500		V
$V_{R(DC)}$	D.C. Reverse Voltage	400		V

Symbol	Item	Conditions	Ratings	Unit	
$I_F (AV)$	Forward Current	D.C. $T_c : 85^\circ\text{C}$	150	A	
I_{FMS}	Surge Forward Current	$1/2$ cycle, 60Hz, peak value, non-repetitive	3000	A	
I^2t	I^2t	Value for one cycle of surge current	37500	A^2S	
T_j	Operating Junction Temperature		-40 to +150	$^\circ\text{C}$	
T_{stg}	Storage Temperature		-40 to +125	$^\circ\text{C}$	
V_{ISO}	Isolation Breakdown Voltage (R.M.S.)	A.C. 1 minute	2500	V	
	Mounting Torque	Mounting (M6)	Recommended Value 2.5-3.9 (25-40)	4.7 (48)	N·m (kgf·cm)
		Terminal (M6)	Recommended Value 2.5-3.9 (25-40)	4.7 (48)	
	Mass	Typical Value	170	g	

Electrical Characteristics

Symbol	Item	Conditions	Ratings			Unit
			Min.	Typ.	Max.	
I_{RRM}	Repetitive Peak Reverse Current	$V_{RRM}=500\text{V}$, $T_j=125^\circ\text{C}$			150	mA
V_{FM}	Forward Voltage Drop	$I_F=150\text{A}$, Inst. measurement			1.30	V
t_{rr}	Reverse Recovery Time	$I_F=150\text{A}$, $-di/dt=150\text{A}/\mu\text{s}$			200	ns
$R_{th(j-c)}$	Thermal Impedance	Junction to case			0.33	$^\circ\text{C}/\text{W}$

