

HYBRID GATE DRIVER IC FOR IGBT

GH-038

TOP



SanRex GH-038 is Hybrid Gate Driver IC for IGBT.

- High Voltage isolation by Photo Coupler
- Enable to drive IGBT up to dual 600V, 300A module
- Operate with single power source
- Support to high-density system design
- Built-in photo coupler with resistor (330Ω)

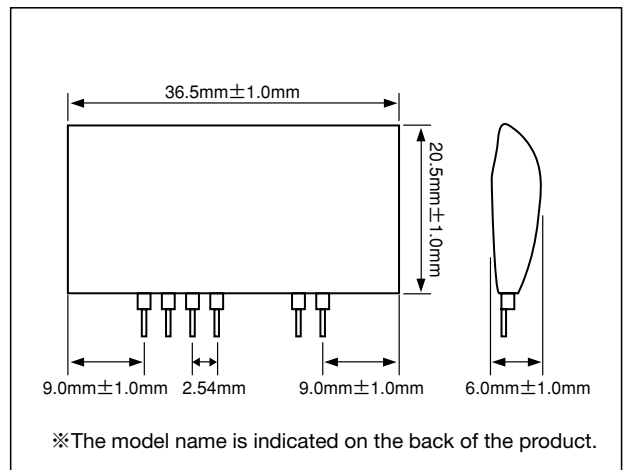

Maximum Ratings

(T_j=25°C unless otherwise specified)

Symbol	Item	Conditions	Ratings			Unit
			Min.	Typ.	Max.	
V _{CC}	Supply Voltage		23.0	26.0	28.0	V
V _{OH}	Forward Bias Output Voltage	V _{CC} =26.0V	16.0	18.0	19.0	V
V _{RB}	Reverse Bias Supply Voltage	V _{CC} =26.0V	7.0	8.0	9.0	V
V _{FIN}	Photo Coupler Input Voltage			5.0	7.0	V
I _F	Photo Coupler Input Current	V _{FIN} =5.0V	9.0	10.6	12.2	mA
I _{g1}	Output Forward Current	PW=2 μs, Duty cycle=less than 0.05		4.0	6.0	A
I _{g2}	Output Reverse Current	PW=2 μs, Duty cycle=less than 0.05		4.0	6.0	A
t _{PLH}	Switching Time-High side	V _{CC} =26.0V, I _F =10mA			1.5	μs
t _{PHL}	Switching Time-Low side	V _{CC} =26.0V, I _F =10mA			1.5	μs
t _r	Rise Time	V _{CC} =26.0V, I _F =10mA			1.0	μs
t _f	Fall Time	V _{CC} =26.0V, I _F =10mA			1.0	μs
dv/dt	Noise immunity		5k	10k		V/μs
Visc	Input/Output Isolation Voltage	AC50/60Hz, 1minute	AC2500			V
Topr	Operational Ambient Temperature		-25 to +80			°C
Tstg	Storage Temperature		-40 to +125			°C

Equivalent Circuit

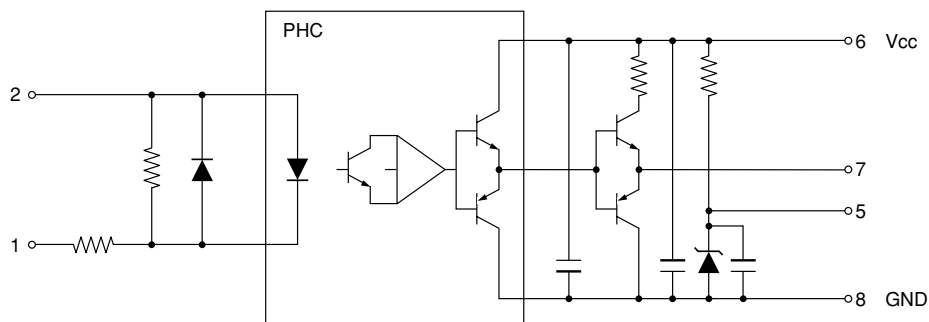

■ Example of Application

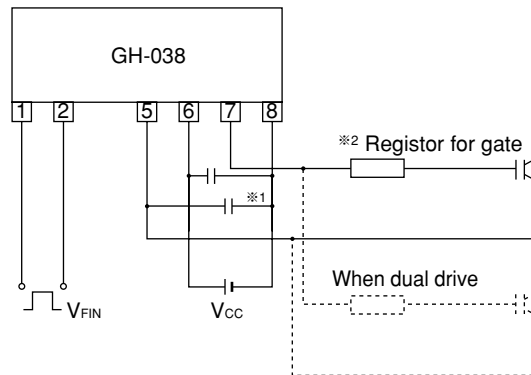

- ※1 Design the capacitor (more than 10 μ F) for stabilized voltage to be connected as close to the Driver IC as possible.
- ※2 For the value of resistor for gate, the resistance value described in IGBT Module specification is recommended. The gate resistance should be determined at less than 6A of peak output current judging from signal delay time and surge voltage.

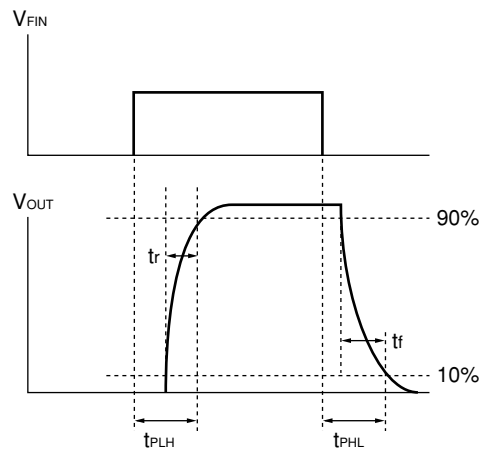

• Switching wave form