

# GL78XX Series

## POSITIVE VOLTAGE REGULATOR

### Description

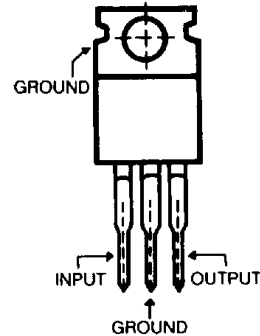
The GL78XX Series are monolithic integrated circuits designed as fixed-voltage regulator. These regulators employ internal current limiting, thermal shutdown, and safe-area compensation. With adequate heatsinking they can deliver over 1.5A output currents. They are intended as fixed voltage regulators in a wide range of applications.

### Features

- No External Components Required
- High Line Regulation
- High Load Regulation
- Good Ripple Rejection (70dB)
- Low Temperature Coefficient of Output (1.0mV/°C)
- Wide Range Input Voltage
- Low Input Bias Current
- Low Output Noise
- Output Current in Excess of 1.5A

### Pin Configuration

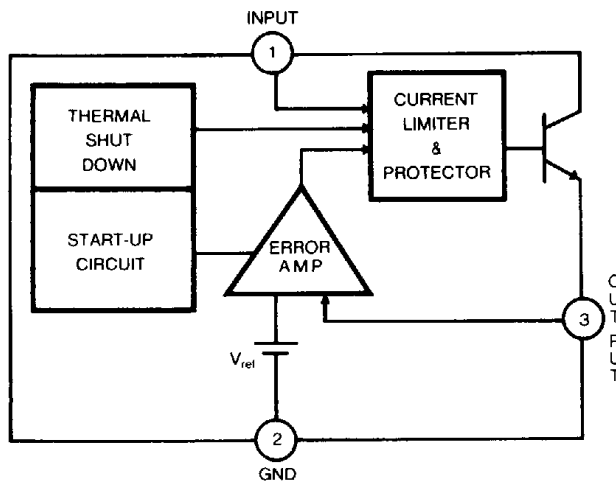
(Top View)



### Type No/Voltage

GL7805	5.0 Volts
GL7806	6.0 Volts
GL7808	8.0 Volts
GL7809	9.0 Volts
GL7812	12.0 Volts
GL7815	15.0 Volts
GL7824	24.0 Volts

### Block Diagram



### Absolute Maximum Ratings ( $T_A = 25^\circ\text{C}$ )

- Input Voltage (5V Through 15V) 35V
- Input Voltage (24V) 40V
- Output Current 3.3A
- Power Dissipation 15W
- Operating Junction Temp.  $0^\circ\text{C}$  to  $+125^\circ\text{C}$
- Storage Temp.  $-65^\circ\text{C}$  to  $+150^\circ\text{C}$
- Lead Temp. (Soldering, 10S)  $230^\circ\text{C}$

# GL78XX Series

## GL7805 Electrical Characteristics ( $T_A = 25^\circ\text{C}$ )

PARAMETER	SYMBOL	TEST CONDITIONS	VALUES		UNIT	
			MIN	MAX		
Output Voltage (1)	$V_{O1}$	$T_J = 25^\circ\text{C}$ , $V_{in} = 10\text{V}$ , $I_o = 500\text{mA}$	4.8	5.2	V	
Output Voltage (2)	$V_{O2}$	$7\text{V} \leq V_{in} \leq 20\text{V}$ , $5.0\text{mA} \leq I_o \leq 1.0\text{A}$	4.75	5.25	V	
Line Regulation	$\Delta V_{O1}$	$T_J = 25^\circ\text{C}$		$7 \leq V_{in} \leq 25\text{V}$ , $I_o = 500\text{mA}$	50	mV
	$\Delta V_{O2}$			$8\text{V} \leq V_{in} \leq 12\text{V}$ , $I_o = 500\text{mA}$	25	mV
Load Regulation	$\Delta V_{O3}$	$T_J = 25^\circ\text{C}$		$5.0\text{mA} \leq I_o \leq 1.5\text{A}$ , $V_{in} = 10\text{V}$	50	mV
	$\Delta V_{O4}$			$250\text{mA} \leq I_o \leq 750\text{mA}$ , $V_{in} = 10\text{V}$	25	mV
Quiescent Current	$I_Q$	$T_J = 25^\circ\text{C}$ , $V_{in} = 10\text{V}$ , $I_o = 500\text{mA}$		8	mA	
Quiescent Current Change	$\Delta I_{Q1}$	$7\text{V} \leq V_{in} \leq 25\text{V}$ , $I_o = 500\text{mA}$		1.3	mA	
	$\Delta I_{Q2}$	$5.0\text{mA} \leq I_o \leq 1.0\text{A}$ , $V_{in} = 10\text{V}$		0.5	mA	
Output Noise Voltage	$N_o$	$V_{in} = 10\text{V}$ , $I_o = 500\text{mA}$ , $10\text{Hz} \leq f \leq 100\text{KHz}$	40(TYP)		$\mu\text{V}$	
Ripple Rejection	$R_R$	$T_J = 25^\circ\text{C}$ , $V_i = 1V_{(rms)}$ 120Hz, $I_o = 20\text{mA}$ , $8\text{V} \leq V_{in} \leq 18\text{V}$	62		dB	
Input-Output Voltage Differential	$V_d$	$T_J = 25^\circ\text{C}$ , $I_o = 1.0\text{A}$	2(TYP)		V	
Short-Circuit Limit	$I_{sc}$	$V_{in} = 35\text{V}$ , Output-GND		1.0	A	
Peak Output Current	$I_{peak}$	$T_J = 25^\circ\text{C}$ , $V_{in} = 12\text{V}$ , $V_O = 4.75\text{V}$	1.5	3.3	A	

## GL7806 Electrical Characteristics ( $T_A = 25^\circ\text{C}$ )

PARAMETER	SYMBOL	TEST CONDITIONS	VALUES		UNIT	
			MIN	MAX		
Output Voltage (1)	$V_{O1}$	$T_J = 25^\circ\text{C}$ , $V_{in} = 11\text{V}$ , $I_o = 500\text{mA}$	5.75	6.25	V	
Output Voltage (2)	$V_{O2}$	$8\text{V} \leq V_{in} \leq 21\text{V}$ , $5.0\text{mA} \leq I_o \leq 1.0\text{A}$	5.7	6.3	V	
Line Regulation	$\Delta V_{O1}$	$T_J = 25^\circ\text{C}$		$8 \leq V_{in} \leq 25\text{V}$ , $I_o = 500\text{mA}$	60	mV
	$\Delta V_{O2}$			$9\text{V} \leq V_{in} \leq 13\text{V}$ , $I_o = 500\text{mA}$	30	mV
Load Regulation	$\Delta V_{O3}$	$T_J = 25^\circ\text{C}$		$5\text{mA} \leq I_o \leq 1.5\text{A}$ , $V_{in} = 11\text{V}$	60	mV
	$\Delta V_{O4}$			$250\text{mA} \leq I_o \leq 750\text{mA}$ , $V_{in} = 11\text{V}$	30	mV
Quiescent Current	$I_Q$	$T_J = 25^\circ\text{C}$ , $V_{in} = 11\text{V}$ , $I_o = 500\text{mA}$		8.0	mA	
Quiescent Current Change	$\Delta I_{Q1}$	$8\text{V} \leq V_{in} \leq 25\text{V}$ , $I_o = 500\text{mA}$		1.3	mA	
	$\Delta I_{Q2}$	$V_{in} = 11\text{V}$ , $5\text{mA} \leq I_o \leq 1.0\text{A}$		0.5	mA	
Output Noise Voltage	$N_o$	$V_{in} = 11\text{V}$ , $I_o = 500\text{mA}$ , $10\text{Hz} \leq f \leq 100\text{KHz}$	45(TYP)		$\mu\text{V}$	
Ripple Rejection	$R_R$	$T_J = 25^\circ\text{C}$ , $V_i = 1V_{(rms)}$ 120Hz, $I_o = 20\text{mA}$ , $9\text{V} \leq V_{in} \leq 19\text{V}$	57		dB	
Input-Output Voltage Differential	$V_d$	$T_J = 25^\circ\text{C}$ , $I_o = 1.0\text{A}$	2(TYP)		V	
Short-Circuit Limit	$I_{sc}$	$V_{in} = 35\text{V}$ , Output-GND		1.0	A	
Peak Output Current	$I_{peak}$	$T_J = 25^\circ\text{C}$ , $V_{in} = 13\text{V}$ , $V_O = 5.7\text{V}$	1.5	3.3	A	

## GL7808 Electrical Characteristics ( $T_A = 25^\circ\text{C}$ )

PARAMETER	SYMBOL	TEST CONDITIONS	VALUES		UNIT	
			MIN.	MAX.		
Output Voltage (1)	$V_{O1}$	$T_J = 25^\circ\text{C}$ , $V_{in} = 14\text{V}$ , $I_o = 500\text{mA}$	7.7	8.3	V	
Output Voltage (2)	$V_{O2}$	$10.5\text{V} \leq V_{in} \leq 23\text{V}$ , $5.0\text{mA} \leq I_o \leq 1.0\text{A}$	7.6	8.4	V	
Line Regulation	$\Delta V_{O1}$	$T_J = 25^\circ\text{C}$	$10.5\text{V} \leq V_{in} \leq 25\text{V}$ , $I_o = 500\text{mA}$		80	mV
	$\Delta V_{O2}$		$11\text{V} \leq V_{in} \leq 17\text{V}$ , $I_o = 500\text{mA}$		40	mV
Load Regulation	$\Delta V_{O3}$	$T_J = 25^\circ\text{C}$	$5.0\text{mA} \leq I_o \leq 1.5\text{A}$ , $V_{in} = 14\text{V}$		80	mV
	$\Delta V_{O4}$		$250\text{mA} \leq I_o \leq 750\text{mA}$ , $V_{in} = 14\text{V}$		40	mV
Quiescent Current	$I_Q$	$T_J = 25^\circ\text{C}$ , $V_{in} = 14\text{V}$ , $I_o = 500\text{mA}$		8.0	mA	
Quiescent Current Change	$\Delta I_{Q1}$	$10.5\text{V} \leq V_{in} \leq 25\text{V}$ , $I_o = 500\text{mA}$		1.0	mA	
	$\Delta I_{Q2}$	$5\text{mA} \leq I_o \leq 1.0\text{A}$ , $V_{in} = 14\text{V}$		0.5	mA	
Output Noise Voltage	$N_o$	$V_{in} = 14\text{V}$ , $I_o = 500\text{mA}$ , $10\text{Hz} \leq f \leq 100\text{KHz}$	52(TYP)		$\mu\text{V}$	
Ripple Rejection	$R_R$	$T_J = 25^\circ\text{C}$ , $V_i = 1\text{V}_{(rms)}$ , $120\text{Hz}$ , $I_o = 20\text{mA}$ , $11.5\text{V} \leq V_{in} \leq 21.5\text{V}$	55		dB	
Input-Output Voltage Differential	$V_d$	$T_J = 25^\circ\text{C}$ , $I_o = 1.0\text{A}$	2(TYP)		V	
Short-Circuit Limit	$I_{sc}$	$V_{in} = 35\text{V}$ , Output-GND		1.0	A	
Peak Output Current	$I_{peak}$	$T_J = 25^\circ\text{C}$ , $V_{in} = 15\text{V}$ , $V_O = 7.6\text{V}$	1.5	3.3	A	

## GL7809 Electrical Characteristics ( $T_A = 25^\circ\text{C}$ )

PARAMETER	SYMBOL	TEST CONDITIONS	VALUES		UNIT	
			MIN.	MAX.		
Output Voltage (1)	$V_{O1}$	$T_J = 25^\circ\text{C}$ , $V_{in} = 15\text{V}$ , $I_o = 500\text{mA}$	8.64	9.36	V	
Output Voltage (2)	$V_{O2}$	$11.5\text{V} \leq V_{in} \leq 24\text{V}$ , $5.0\text{mA} \leq I_o \leq 1.0\text{A}$	8.55	9.45	V	
Line Regulation	$\Delta V_{O1}$	$T_J = 25^\circ\text{C}$	$11.5\text{V} \leq V_{in} \leq 26\text{V}$ , $I_o = 500\text{mA}$		90	mV
	$\Delta V_{O2}$		$12\text{V} \leq V_{in} \leq 18\text{V}$ , $I_o = 500\text{mA}$		45	mV
Load Regulation	$\Delta V_{O3}$	$T_J = 25^\circ\text{C}$	$5.0\text{mA} \leq I_o \leq 1.5\text{A}$ , $V_{in} = 15\text{V}$		90	mV
	$\Delta V_{O4}$		$250\text{mA} \leq I_o \leq 750\text{mA}$ , $V_{in} = 15\text{V}$		45	mV
Quiescent Current	$I_Q$	$T_J = 25^\circ\text{C}$ , $V_{in} = 15\text{V}$ , $I_o = 500\text{mA}$		8	mA	
Quiescent Current Change	$\Delta I_{Q1}$	$11.5\text{V} \leq V_{in} \leq 26\text{V}$ , $I_o = 500\text{mA}$		1.0	mA	
	$\Delta I_{Q2}$	$V_{in} = 15\text{V}$ , $5\text{mA} \leq I_o \leq 1.5\text{A}$		0.5	mA	
Output Noise Voltage	$N_o$	$V_{in} = 15\text{V}$ , $I_o = 500\text{mA}$ , $10\text{Hz} \leq f \leq 100\text{KHz}$	60(TYP)		$\mu\text{V}$	
Ripple Rejection	$R_R$	$T_J = 25^\circ\text{C}$ , $V_i = 1\text{V}_{(rms)}$ , $120\text{Hz}$ , $I_o = 20\text{mA}$ , $12.5\text{V} \leq V_{in} \leq 22.5\text{V}$	55		dB	
Input-Output Voltage Differential	$V_d$	$T_J = 25^\circ\text{C}$ , $I_o = 1.0\text{A}$	2(TYP)		V	
Short-Circuit Limit	$I_{sc}$	$V_{in} = 35\text{V}$ , Output-GND		1.0	A	
Peak Output Current	$I_{peak}$	$T_J = 25^\circ\text{C}$ , $V_{in} = 16\text{V}$ , $V_O = 8.55\text{V}$	1.5	3.3	A	

## GL7812 Electrical Characteristics ( $T_A = 25^\circ\text{C}$ )

PARAMETER	SYMBOL	TEST CONDITIONS	VALUES		UNIT
			MIN.	MAX.	
Output Voltage (1)	$V_{O1}$	$T_J = 25^\circ\text{C}$ , $V_{in} = 19\text{V}$ , $I_o = 500\text{mA}$	11.5	12.5	V
Output Voltage (2)	$V_{O2}$	$14.5\text{V} \leq V_{in} \leq 27.0\text{V}$ , $5.0\text{mA} \leq I_o \leq 1.0\text{A}$	11.4	12.6	V
Line Regulation	$\Delta V_{O1}$	$T_J = 25^\circ\text{C}$	$14.5\text{V} \leq V_{in} \leq 30\text{V}$ , $I_o = 500\text{mA}$	120	mV
	$\Delta V_{O2}$		$16.0\text{V} \leq V_{in} \leq 22\text{V}$ , $I_o = 500\text{mA}$	60	mV
Load Regulation	$\Delta V_{O3}$	$T_J = 25^\circ\text{C}$	$5.0\text{mA} \leq I_o \leq 1.5\text{A}$ , $V_{in} = 19\text{V}$	120	mV
	$\Delta V_{O4}$		$250\text{mA} \leq I_o \leq 750\text{mA}$ , $V_{in} = 19\text{V}$	60	mV
Quiescent Current	$I_Q$	$T_J = 25^\circ\text{C}$ , $V_{in} = 19\text{V}$ , $I_o = 500\text{mA}$		8.0	mA
Quiescent Current Change	$\Delta I_{Q1}$	$14.5\text{V} \leq V_{in} \leq 30\text{V}$ , $I_o = 500\text{mA}$		1.0	mA
	$\Delta I_{Q2}$	$5.0\text{mA} \leq I_o \leq 1.0\text{A}$ , $V_{in} = 19\text{V}$		0.5	mA
Output Noise Voltage	$N_o$	$V_{in} = 19\text{V}$ , $I_o = 500\text{mA}$ , $10\text{Hz} \leq f \leq 100\text{KHz}$	75(TYP)		$\mu\text{V}$
Ripple Rejection	$R_R$	$T_J = 25^\circ\text{C}$ , $V_i = 1V_{(rms)}$ , $120\text{Hz}$ , $I_o = 20\text{mA}$ , $15\text{V} \leq V_{in} \leq 25\text{V}$	55		dB
Input-Output Voltage Differential	$V_d$	$T_J = 25^\circ\text{C}$ , $I_o = 1.0\text{A}$	2(TYP)		V
Short-Circuit Limit	$I_{sc}$	$V_{in} = 35\text{V}$ , Output-GND		1.0	A
Peak Output Current	$I_{peak}$	$T_J = 25^\circ\text{C}$ , $V_{in} = 19\text{V}$ , $V_O = 11.4\text{V}$	1.5	3.3	A

## GL7815 Electrical Characteristics ( $T_A = 25^\circ\text{C}$ )

PARAMETER	SYMBOL	TEST CONDITIONS	VALUES		UNIT
			MIN.	MAX.	
Output Voltage (1)	$V_{O1}$	$T_J = 25^\circ\text{C}$ , $V_{in} = 23\text{V}$ , $I_o = 500\text{mA}$	14.4	15.6	V
Output Voltage (2)	$V_{O2}$	$17.5\text{V} \leq V_{in} \leq 30\text{V}$ , $5.0\text{mA} \leq I_o \leq 1.0\text{A}$	14.25	15.75	V
Line Regulation	$\Delta V_{O1}$	$T_J = 25^\circ\text{C}$	$17.5\text{V} \leq V_{in} \leq 30\text{V}$ , $I_o = 500\text{mA}$	150	mV
	$\Delta V_{O2}$		$20\text{V} \leq V_{in} \leq 26\text{V}$ , $I_o = 500\text{mA}$	75	mV
Load Regulation	$\Delta V_{O3}$	$T_J = 25^\circ\text{C}$	$5\text{mA} \leq I_o \leq 1.5\text{A}$ , $V_{in} = 23\text{V}$	150	mV
	$\Delta V_{O4}$		$250\text{mA} \leq I_o \leq 750\text{mA}$ , $V_{in} = 23\text{V}$	75	mV
Quiescent Current	$I_Q$	$T_J = 25^\circ\text{C}$ , $V_{in} = 23\text{V}$ , $I_o = 500\text{mA}$		8.0	mA
Quiescent Current Change	$\Delta I_{Q1}$	$17.5\text{V} \leq V_{in} \leq 30\text{V}$ , $I_o = 500\text{mA}$		1.0	mA
	$\Delta I_{Q2}$	$5.0\text{mA} \leq I_o \leq 1.0\text{A}$ , $V_{in} = 23\text{V}$		0.5	mA
Output Noise Voltage	$N_o$	$V_{in} = 23\text{V}$ , $I_o = 500\text{mA}$ , $10\text{Hz} \leq f \leq 100\text{KHz}$	90(TYP)		$\mu\text{V}$
Ripple Rejection	$R_R$	$T_J = 25^\circ\text{C}$ , $V_i = 1V_{(rms)}$ , $120\text{Hz}$ , $I_o = 20\text{mA}$ , $18.5\text{V} \leq V_{in} \leq 28.5\text{V}$	54		dB
Input-Output Voltage Differential	$V_d$	$T_J = 25^\circ\text{C}$ , $I_o = 1.0\text{A}$	2(TYP)		V
Short-Circuit Limit	$I_{sc}$	$V_{in} = 35\text{V}$ , Output-GND		1.0	A
Peak Output Current	$I_{peak}$	$T_J = 25^\circ\text{C}$ , $V_{in} = 22\text{V}$ , $V_O = 14.25\text{V}$	1.5	3.3	A

# GL78XX Series

## GL7818 Electrical Characteristics ( $T_A = 25^\circ\text{C}$ )

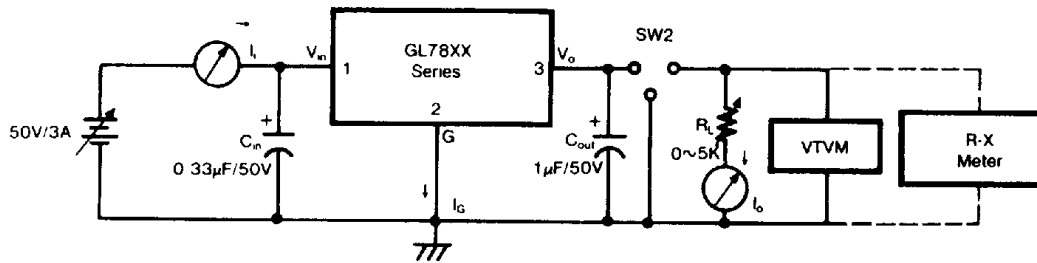
PARAMETER	SYMBOL	TEST CONDITIONS	VALUES		UNIT	
			MIN	MAX		
Output Voltage(1)	$V_{O1}$	$T_J = 25^\circ\text{C}$ , $V_{in} = 25\text{V}$ , $I_o = 500\text{mA}$	17.3	18.7	V	
Output Voltage(2)	$V_{O2}$	$20.5\text{V} \leq V_{in} \leq 33\text{V}$ , $5.0\text{mA} \leq I_o \leq 1.0\text{A}$	17.1	18.9	V	
Line Regulation	$\Delta V_{O1}$	$T_J = 25^\circ\text{C}$		$20.5\text{V} \leq V_{in} \leq 33\text{V}$ , $I_o = 500\text{mA}$	180	mV
	$\Delta V_{O2}$			$24.0\text{V} \leq V_{in} \leq 30\text{V}$ , $I_o = 500\text{mA}$	90	mV
Load Regulation	$\Delta V_{O3}$	$T_J = 25^\circ\text{C}$		$5.0\text{mA} \leq I_o \leq 1.5\text{A}$ , $V_{in} = 21\text{V}$	180	mV
	$\Delta V_{O4}$			$250\text{mA} \leq I_o \leq 750\text{mA}$ , $V_{in} = 25\text{V}$	90	mV
Quiescent Current	$I_Q$	$T_J = 25^\circ\text{C}$ , $V_{in} = 25\text{V}$ , $I_o = 50\text{mA}$		8.0	mA	
Quiescent Current Change	$\Delta I_{Q1}$	$20.5\text{V} \leq V_{in} \leq 33\text{V}$ , $I_o = 500\text{mA}$			1.0	mA
	$\Delta I_{Q2}$			$5.0\text{mA} \leq I_o \leq 1.0\text{A}$ , $V_{in} = 25\text{V}$	0.5	mA
Output Noise Voltage	$N_o$	$V_{in} = 25\text{V}$ , $I_o = 500\text{mA}$ , $10\text{Hz} \leq f \leq 100\text{kHz}$	110(TYP)		$\mu\text{V}$	
Ripple Rejection	$R_R$	$T_J = 25^\circ\text{C}$ , $V_i = 1\text{V}_{(rms)}$ , $120\text{Hz}$ , $I_o = 20\text{mA}$ $21\text{V} \leq V_{in} \leq 33\text{V}$	59		dB	
Input-Output Voltage Differential	$V_d$	$T_J = 25^\circ\text{C}$ , $I_o = 1.0\text{A}$	2(TYP)		V	
Short-Circuit Limit	$I_{sc}$	$V_{in} = 25\text{V}$ , Output-GND		1.0	A	
Peak Output Current	$I_{peak}$	$T_J = 25^\circ\text{C}$ , $V_{in} = 25\text{V}$ , $V_o = 17.1\text{V}$	1.5	3.3	A	

## GL7824 Electrical Characteristics ( $T_A = 25^\circ\text{C}$ )

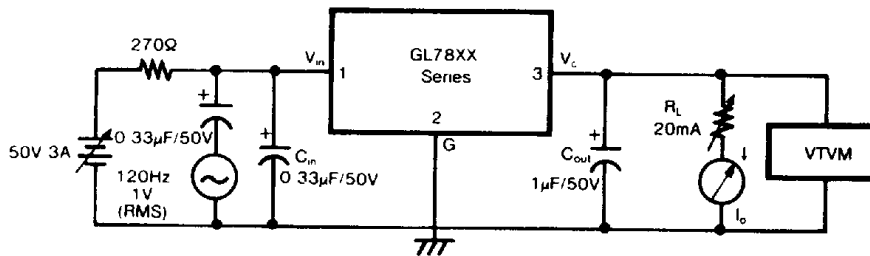
PARAMETER	SYMBOL	TEST CONDITIONS	VALUES		UNIT	
			MIN	MAX		
Output Voltage (1)	$V_{O1}$	$T_J = 25^\circ\text{C}$ , $V_{in} = 33\text{V}$ , $I_o = 500\text{mA}$	23	25	V	
Output Voltage (2)	$V_{O2}$	$27\text{V} \leq V_{in} \leq 38\text{V}$ , $5.0\text{mA} \leq I_o \leq 1.0\text{A}$	22.8	25.2	V	
Line Regulation	$\Delta V_{O1}$	$T_J = 25^\circ\text{C}$		$27\text{V} \leq V_{in} \leq 38\text{V}$ , $I_o = 500\text{mA}$	240	mV
	$\Delta V_{O2}$			$30\text{V} \leq V_{in} \leq 36\text{V}$ , $I_o = 500\text{mA}$	120	mV
Load Regulation	$\Delta V_{O3}$	$T_J = 25^\circ\text{C}$		$5\text{mA} \leq I_o \leq 1.5\text{A}$ , $V_{in} = 33\text{V}$	240	mV
	$\Delta V_{O4}$			$250\text{mA} \leq I_o \leq 750\text{mA}$ , $V_{in} = 33\text{V}$	120	mV
Quiescent Current	$I_Q$	$T_J = 25^\circ\text{C}$ , $V_{in} = 33\text{V}$ , $I_o = 500\text{mA}$		8.0	mA	
Quiescent Current Change	$\Delta I_{Q1}$	$27\text{V} \leq V_{in} \leq 38\text{V}$ , $I_o = 500\text{mA}$			1.0	mA
	$\Delta I_{Q2}$			$5.0\text{mA} \leq I_o \leq 1.0\text{A}$ , $V_{in} = 33\text{V}$	0.5	mA
Output Noise Voltage	$N_o$	$V_{in} = 33\text{V}$ , $I_o = 500\text{mA}$ , $10\text{Hz} \leq f \leq 100\text{kHz}$	170(TYP)		$\mu\text{V}$	
Ripple Rejection	$R_R$	$T_J = 25^\circ\text{C}$ , $V_i = 1\text{V}_{(rms)}$ , $120\text{Hz}$ , $I_o = 20\text{mA}$ , $28\text{V} \leq V_{in} \leq 38\text{V}$	56		dB	
Input-Output Voltage Differential	$V_d$	$T_J = 25^\circ\text{C}$ , $I_o = 1.0\text{A}$	2(TYP)		V	
Short-Circuit Limit	$I_{sc}$	$V_{in} = 35\text{V}$ , Output-GND		1.0	A	
Peak Output Current	$I_{peak}$	$T_J = 25^\circ\text{C}$ , $V_{in} = 31\text{V}$ , $V_o = 22.8\text{V}$	1.5	3.3	A	

## \*GL78XX Series Test Circuit (AC & DC)

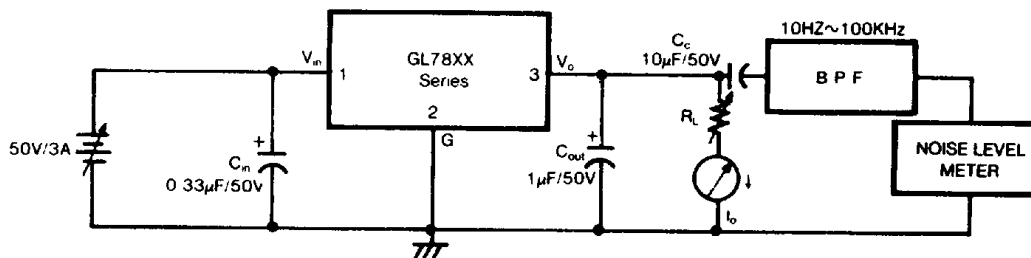
1  $V_{O1}$ ,  $V_{O2}$ ,  $\Delta V_o$ ,  $I_Q$ ,  $\Delta I_Q$ ,  $V_d$ ,  $I_{SC}$ ,  $I_{load}$



2 Ripple Rejection



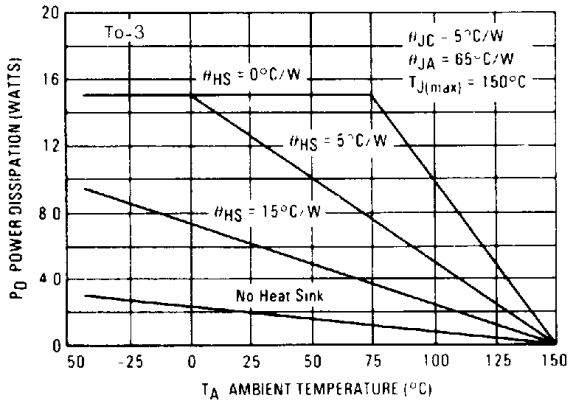
3 Output Noise Voltage



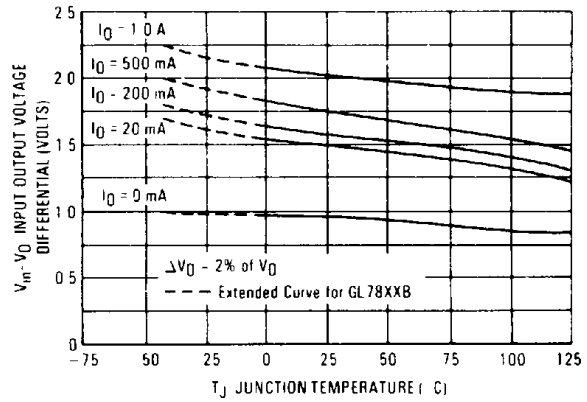
\*  $C_{in}$ ,  $C_{out}$ ,  $C_c$  is Tantalum Capacitor

## TYPICAL CHARACTERISTICS ( $T_A = +25^\circ\text{C}$ unless otherwise noted)

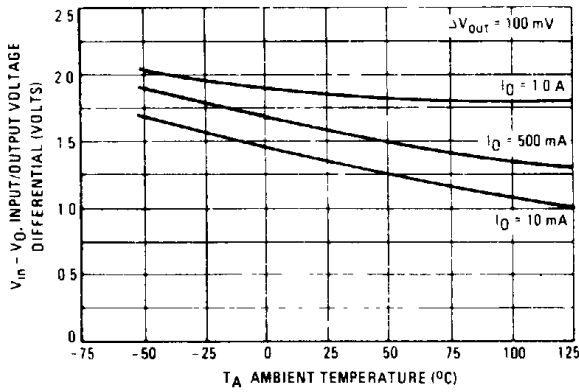
**FIGURE 1 – AVERAGE POWER DISSIPATION versus AMBIENT TEMPERATURE**



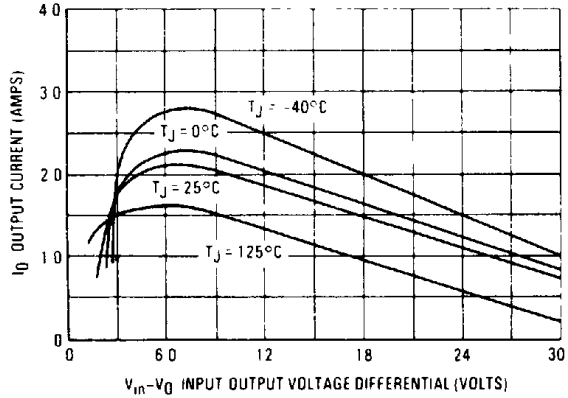
**FIGURE 2 – INPUT OUTPUT DIFFERENTIAL AS A FUNCTION OF JUNCTION TEMPERATURE**



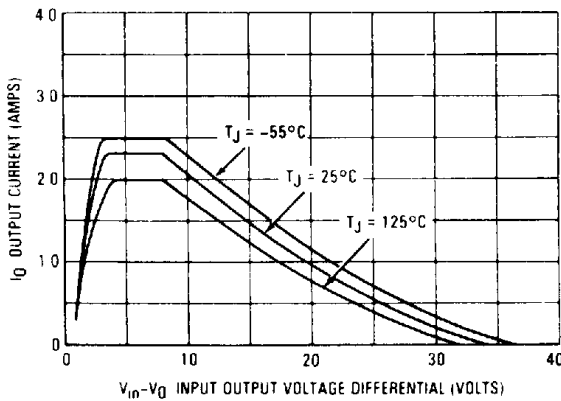
**FIGURE 3 – INPUT OUTPUT DIFFERENTIAL AS A FUNCTION OF JUNCTION TEMPERATURE**



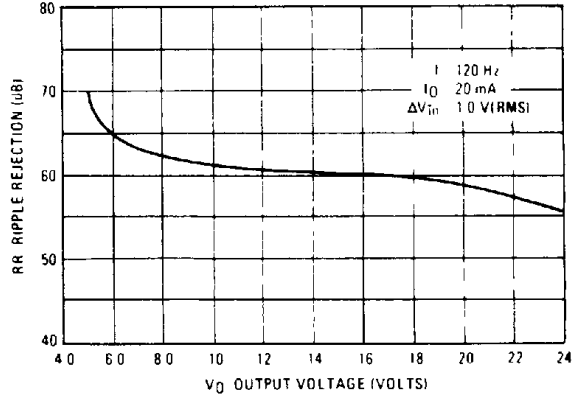
**FIGURE 4 – PEAK OUTPUT CURRENT AS A FUNCTION OF INPUT-OUTPUT DIFFERENTIAL VOLTAGE**



**FIGURE 5 – PEAK OUTPUT CURRENT AS A FUNCTION OF INPUT-OUTPUT DIFFERENTIAL VOLTAGE**

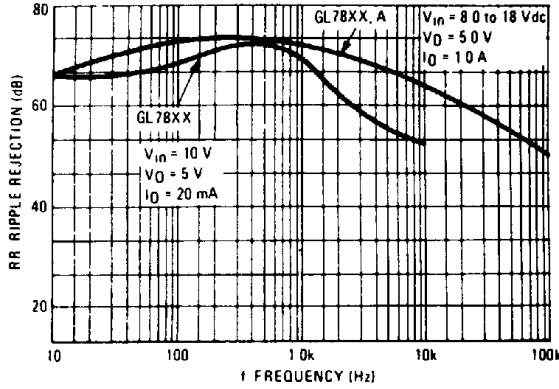


**FIGURE 6 – RIPPLE REJECTION AS A FUNCTION OF OUTPUT VOLTAGES**

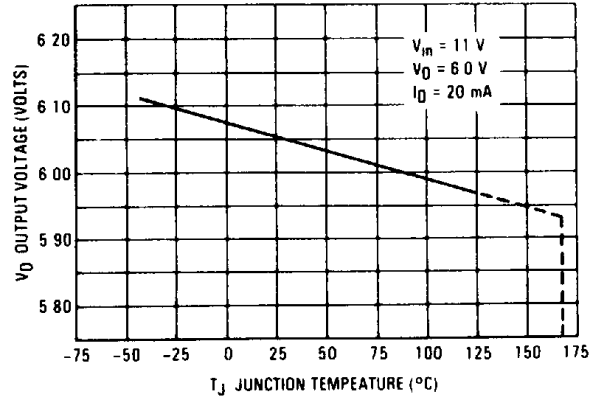


**TYPICAL CHARACTERISTICS (continued)**  
( $T_A = 25^\circ\text{C}$  unless otherwise noted.)

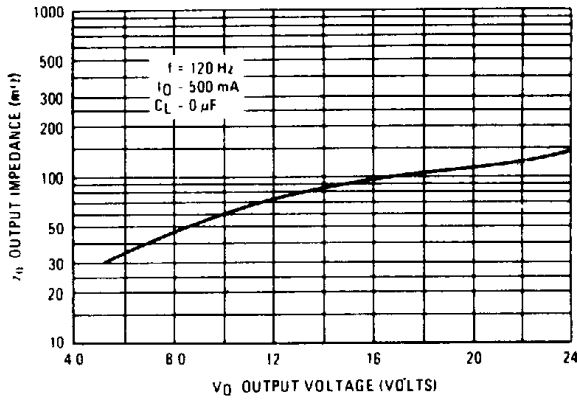
**FIGURE 7 – RIPPLE REJECTION AS A FUNCTION OF FREQUENCY**



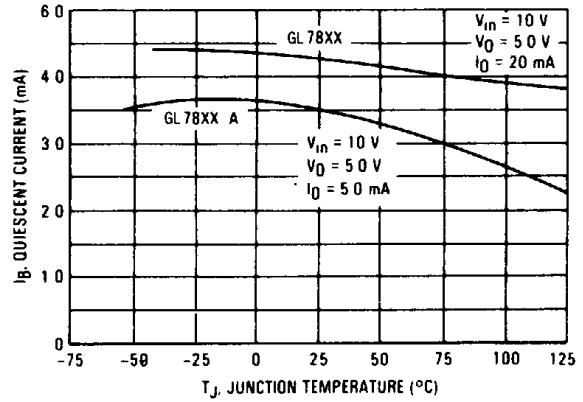
**FIGURE 8 – OUTPUT VOLTAGE AS A FUNCTION OF JUNCTION TEMPERATURE**



**FIGURE 9 – OUTPUT IMPEDANCE AS A FUNCTION OF OUTPUT VOLTAGE**



**FIGURE 10 – QUIESCENT CURRENT AS A FUNCTION OF TEMPERATURE**



**FIGURE 11 – DROPOUT CHARACTERISTICS**

