

HA SERIES AUDIO CONNECTORS—MODELS HA16•HA216•HA316 CONNECTORS

Introduction

The HA16 series are acoustic circular latch-lock connectors designed for use mainly with microphones, microphone mixers, and other broadcasting equipment.

Having a ground function, the HA16 series not only prevent external noise but also give a feeling of integration with your equipment due to their simple, refined design.

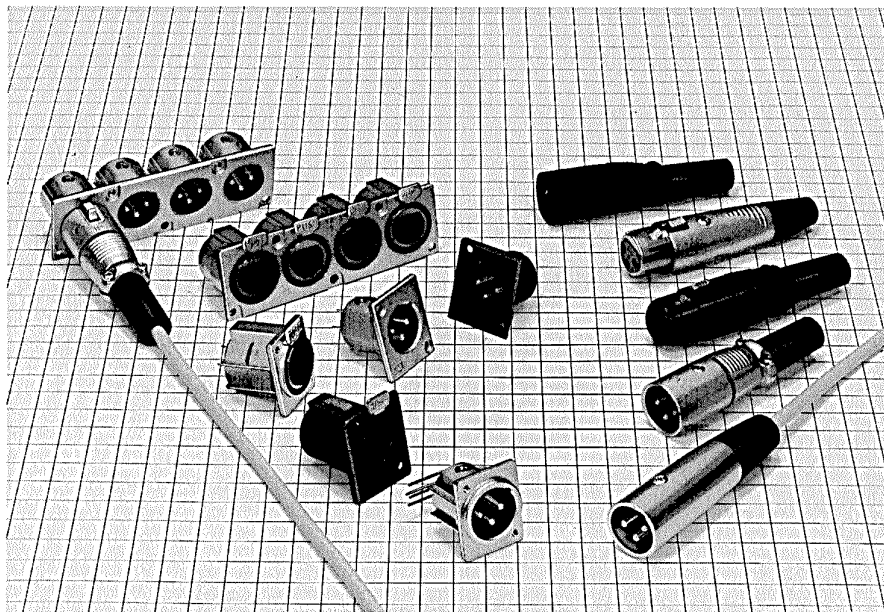

Features

- (1) For your choice according to your equipment, two types of plug-side connectors are available; the HA16 streamlined with a simple, refined design and inside cable-clamping mechanism, and the HA216 and HA316 designed to be two screws with an exposed cable-clamping mechanism.
- (2) To meet the needs of miniature equipment, the receptacle-side connectors are available in four sizes to fit your equipment. Three-pin models are available in four strip terminals to give you a wide choice.
- (3) The lock release levers in the plug receptacle come in two types: the push-pull type and the easier-to-operate lever pushdown type. This allows you to select the type that meets your application needs.
- (4) The receptacle side connectors are available in soldered and board dip types. The board dip type can be mounted from inside, enabling further labor-saving in terminating work.
- (5) An ultra-high-fidelity version is available, using terminals made from 6N high-purity oxygen-free copper.
- (6) The ultra-high-fidelity plugs and jacks are marked in red or white for easy identification of the right and left leads.

Plug

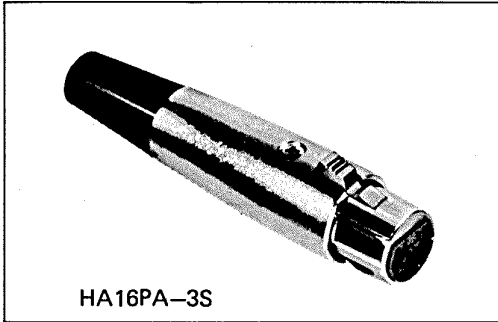

Guide Key

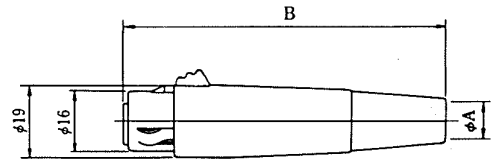
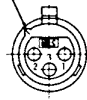

(An example in shape)

HRS No.	Part No.	No. of pins	φA	B	Weight	Remarks
104-0359-0	HA16PA-3S	3	4.5	86	50gr	
104-0363-8	HA16PD-3S	3	6	86	50gr	
104-0388-9	HA16PK-3S	3	6	79	50gr	
104-0426-6	HA16PK-4S	4	6	78	50gr	
104-0351-9	HA16PA-5S	5	4.5	86	50gr	
104-0366-6	HA16PD-5S	5	6	86	50gr	

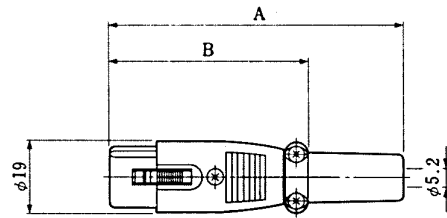
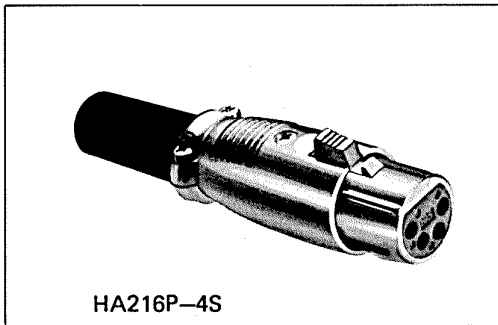

(An example in shape)

HRS No.	Part No.	No. of pins	A	B	Weight	Remarks
104-0701-9	HA216P-3S	3	78.5	53.5	40gr	
104-0702-1	HA216P-4S	4	77.7	52.7	40gr	
104-0703-4	HA216P-5S	5	78.5	53.5	40gr	

(Rubber Insert Type)

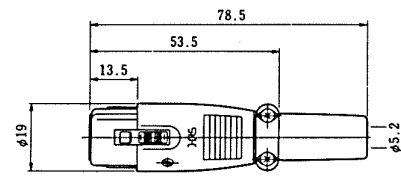
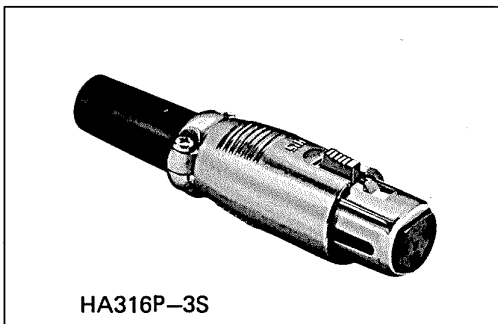

(An example in shape)

HRS No.	Part No.	No. of pins	Weight	Remarks
104-1101-7	HA316P-3S	3	45gr	
104-1113-6	HA316PB-3S	3	45gr	Gold-plated, Black
104-1102-0	HA316P-4S	4	45gr	
104-1103-2	HA316P-5S	5	45gr	
104-1104-5	HA316P-7S	7	45gr	

Jack

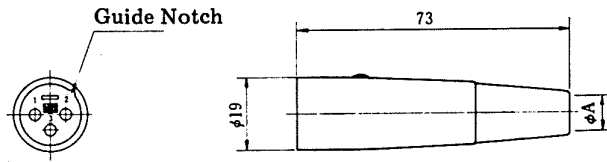
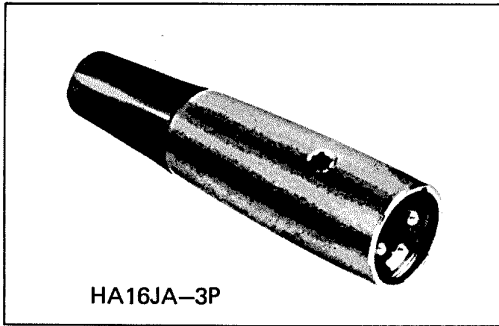

(An example in shape)

HRS No.	Part No.	No. of pin	ϕA	Weight
104-0358-8	HA16JA-3P	3	4.5	40gr
104-0364-0	HA16JD-3P	3	6	40gr
104-0367-9	HA16JA-5P	5	4.5	40gr
104-0368-1	HA16JD-5P	5	6	40gr

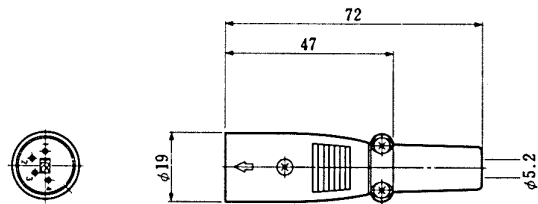
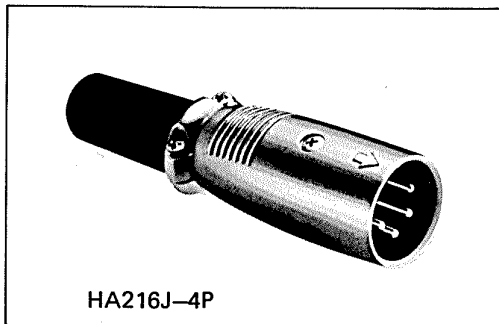

(An example in shape)

HRS No.	Part No.	No. of pins	Weight	Remarks
104-0704-7	HA216J-3P	3	40gr	
104-0708-8	HA216JB-3P	3	40gr	Gold-plated, Black
104-0705-0	HA216J-4P	4	40gr	
104-0706-2	HA216J-5P	5	40gr	
104-0707-5	HA216J-7P	7	40gr	

Receptacle (Solder Type)

(Large Flange Type)

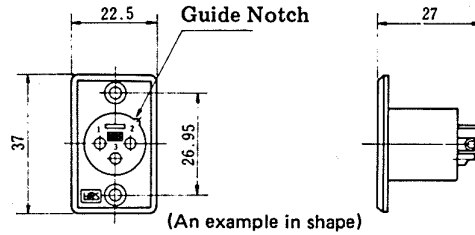
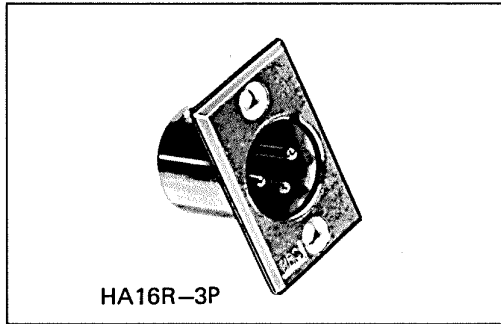

(An example in shape)

HRS No.	Part No.	No. of pin	Weight
104-0349-7	HA16R-3P	3	13gr
104-0434-4	HA16R-4P	4	13gr
104-0369-4	HA16R-5P	5	13gr

(Medium Flange Type)

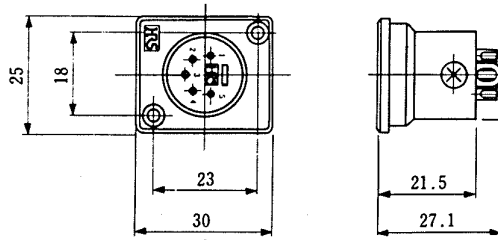
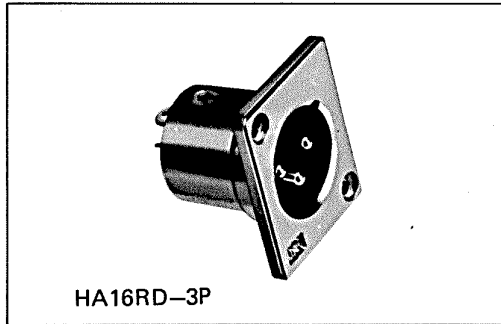

(An example in shape)

HRS No.	Part No.	No. of pins	Weight	Remarks
104-0393-9	HA16RD-3P	3	14gr	
104-0393-9-10	HA16RD-3P(10)	3	14gr	Gold-plated, Black
104-0402-8	HA16RD-4P	4	14gr	
104-0499-0	HA16RD-7P	7	14gr	

(Small Flange Type)

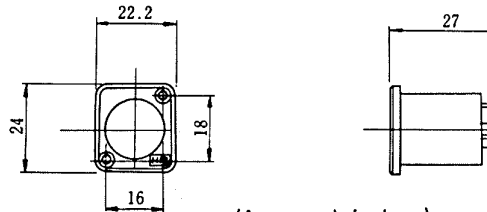
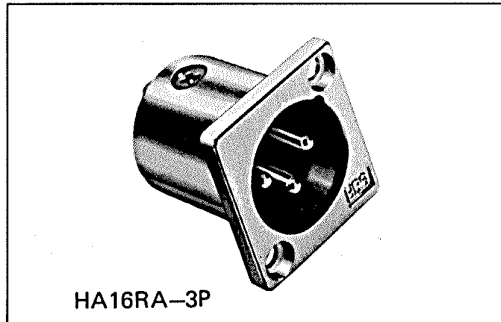

(An example in shape)

HRS No.	Part No.	No. of pins	Weight
104-0382-2	HA16RA-3P	3	11gr
104-0408-4	HA16RA-4P	4	11gr
104-0383-5	HA16RA-5P	5	11gr

(Inside Mount Type)

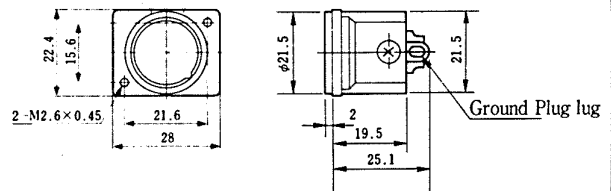
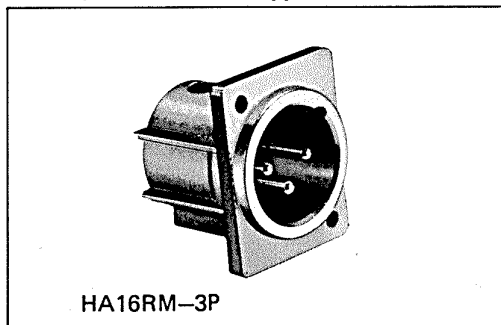

(An example in shape)

HRS No.	Part No.	No. of pin	Weight
104-0431-6	HA16RM-3P	3	14gr

Receptacle (PCB Dip Type)

(Medium Flange Type, Straight Dip)

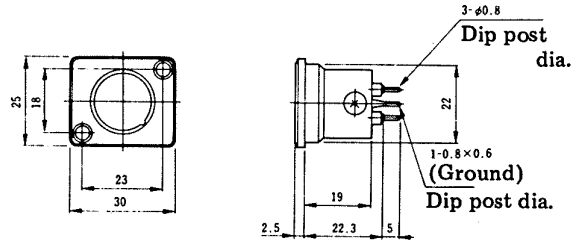
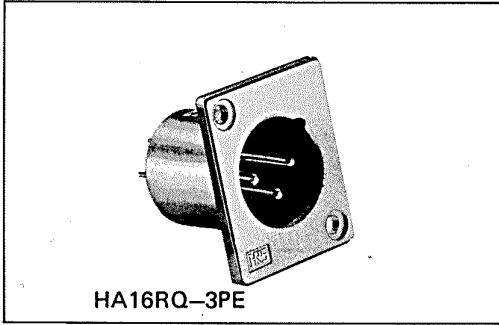

(An example in shape)

HRS No.	Part No.	No. of pin	Weight	Remarks
104-0435-7	HA16RQ-3PE	3	14gr	

(Inside Mount Type, Straight Dip)

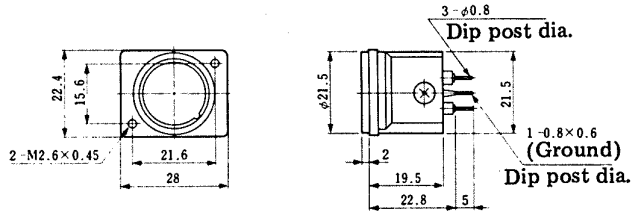
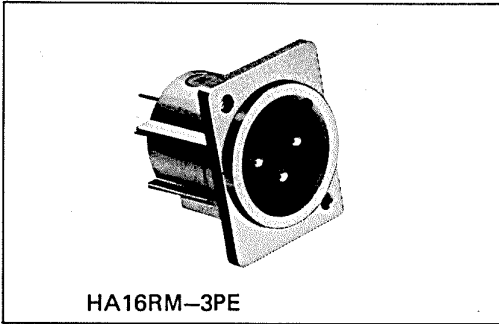

(An example in shape)

HRS No.	Part No.	No. of pin	A	B	C	D	Weight	Remarks
104-0420-0	HA16RM-3PE	3	15.6	M2.6×0.45	19.5	0.8×0.6	14gr	
104-0464-5	HA16RY-3PE	3	17.4	M3×0.5	-	0.7×0.4	30gr	

(Inside Mount Type, Right Angle Dip)

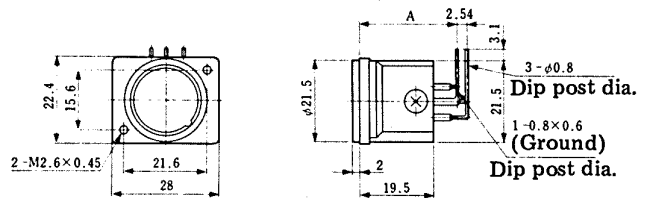
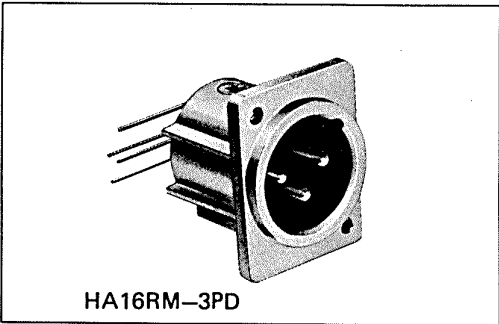

(The above shapes are examples. The left bend type is shown in this figure.)

HRS No.	Part No.	No. of pin	A	Weight	Remarks
104-0414-7	HA16RM-3PA	3	25.8	14gr	Dip post right turn
104-0416-2	HA16RM-3PB	3	23.2	14gr	Dip post down turn
104-0418-8	HA16RM-3PD	3	25.8	14gr	Dip post left turn

Plug-Receptacle (Solder Type)

(Small Flange Type)

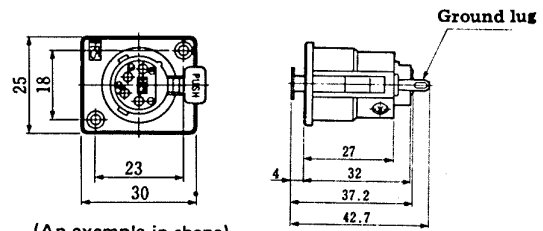
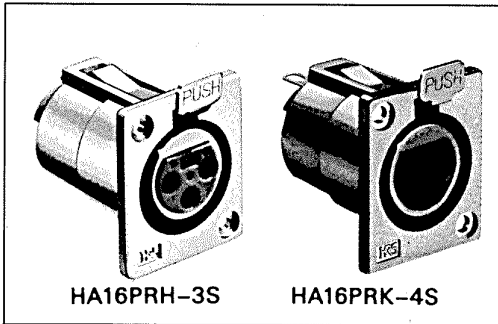

(An example in shape)

HRS No.	Part No.	No. of pin	Weight	Remarks
104-0395-4	HA16PRH-3S	3	26gr	Without ground lug
104-0403-0	HA16PRH-4S	4	26gr	Without ground lug
104-0404-3	HA16PRH-5S	5	26gr	Without ground lug
104-0411-9	HA16PRK-3S	3	26gr	With ground lug
104-0427-9	HA16PRK-4S	4	26gr	With ground lug

(Small Flange Type, Rubber Insert)

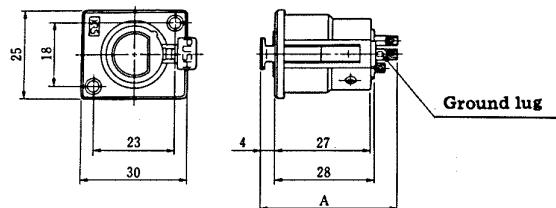
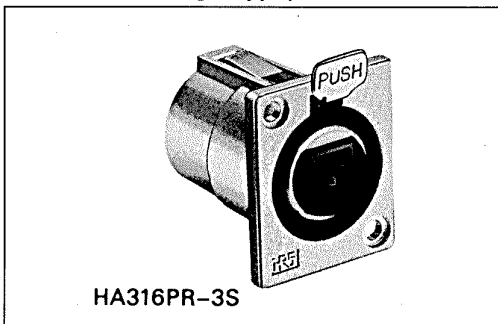

(An example in shape)

HRS No.	Part No.	No. of pins	A	Weight	Remarks
104-1105-8	HA316PR-3S	3	37.5	28gr	
104-1105-8-10	HA316PR-3S(10)	3	37.5	28gr	Gold-plated, Black
104-1106-0	HA316PR-4S	4	37.4	28gr	
104-1107-3	HA316PR-5S	5	37.4	28gr	
104-1108-6	HA316PR-7S	7	36.3	28gr	

(Small Flange Type, Rubber Insert)

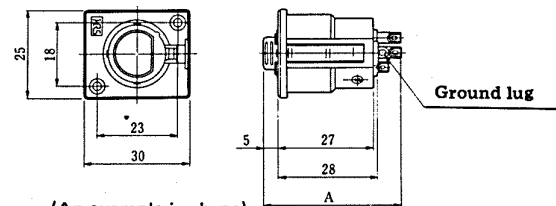
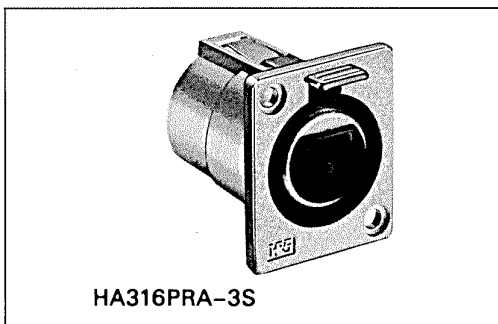

(An example in shape)

HRS No.	Part No.	No. of pins	A	Weight	Remarks
104-1109-9	HA316PRA-3S	3	38.5	28gr	
104-1110-8	HA316PRA-4S	4	38.4	28gr	
104-1111-0	HA316PRA-5S	5	38.4	28gr	
104-1112-3	HA316PRA-7S	7	37.3	28gr	

(Inside Mount Type)

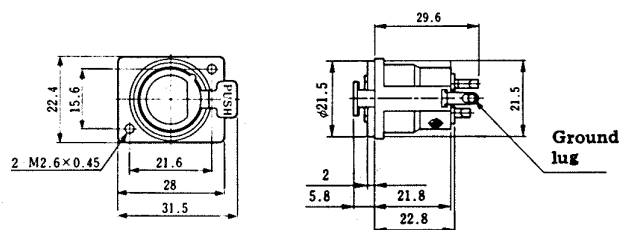
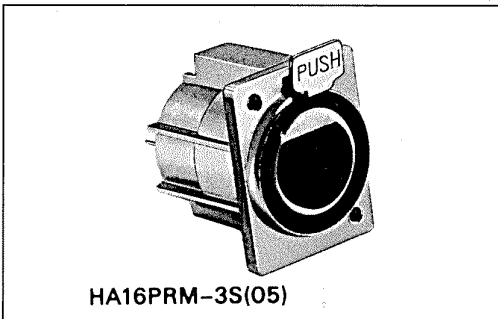

(An example in shape)

HRS No.	Part No.	No. of pin	Weight	Remarks
104-0432-9-05	HA16PRM-3S(05)	3	18gr	

Plug-Receptacle (PCB Dip Type)

(Small Flange Type, Straight Dip)

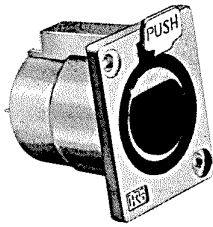

HA16PRQ-3SE(05)

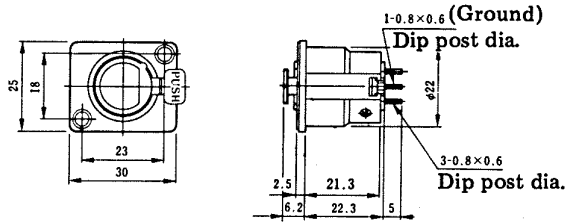

(An example in shape)

HRS No.	Part No.	No. of pin	Weight	Remarks
104-0436-0-05	HA16PRQ-3SE(05)	3	26gr	

(Inside Mount Type, Straight Dip)

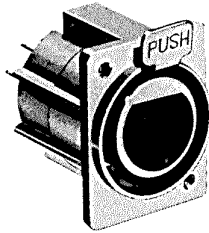

HA16PRM-3SE(05)

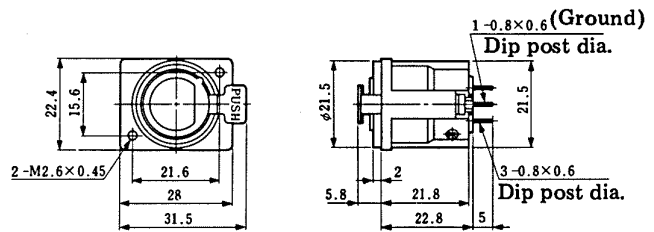

(An example in shape)

HRS No.	Part No.	No. of pin	Weight	Remarks
104-0421-2-05	HA16PRM-3SE(05)	3	18gr	

(Inside Mount Type, Straight Dip)

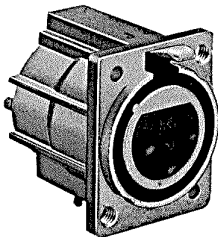

HA16PRY-3SE

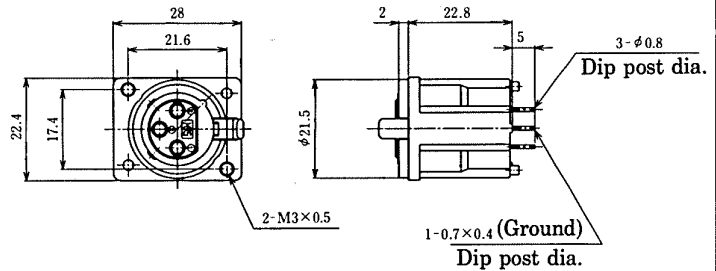

HRS No.	Part No.	No. of pin	Weight	Remarks
104-0465-8	HA16PRY-3SE	3	32gr	

(Inside Mount Type, Right Angle Dip)

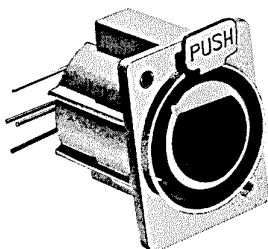

HA16PRM-3SD(05)

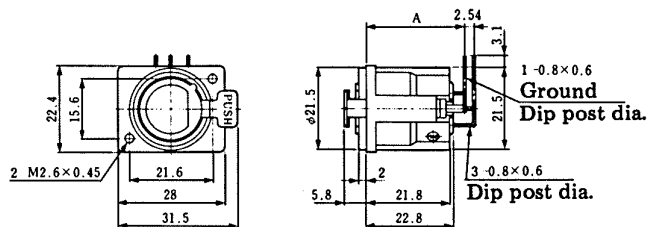

(An example in shape)

HRS No.	Part No.	No. of pin	Weight	A	Remarks
104-0415-0-05	HA16PRM-3SA(05)	3	18gr	25.8	Dip post right turn
104-0417-5-05	HA16PRM-3SB(05)	3	18gr	23.2	Dip post down turn
104-0419-0-05	HA16PRM-3SD(05)	3	18gr	25.8	Dip post left turn

Gang Type

(Receptacle Solder Type)

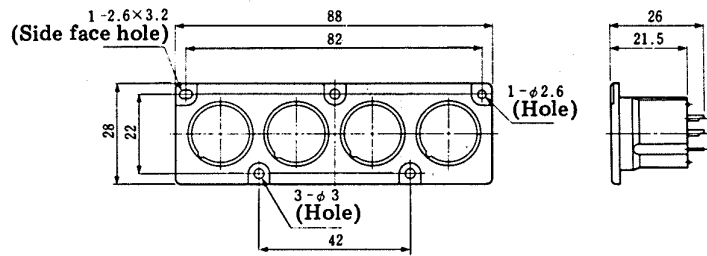
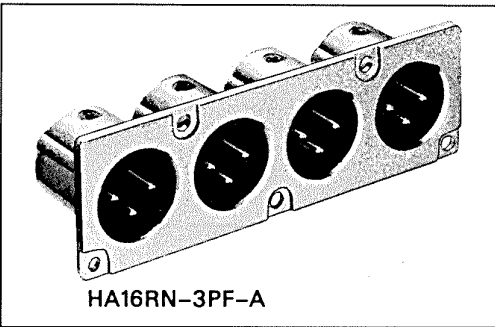

(An example in shape)

HRS No.	Part No.	No. of pin	Weight	Remarks
104-0422-5	HA16RN-3PF-A	3	48gr	4 chain type

(Receptacle PCB Dip Type)

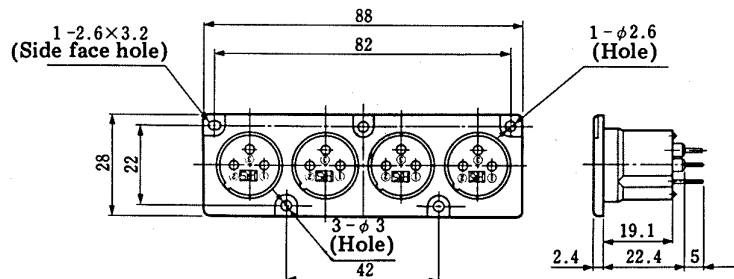
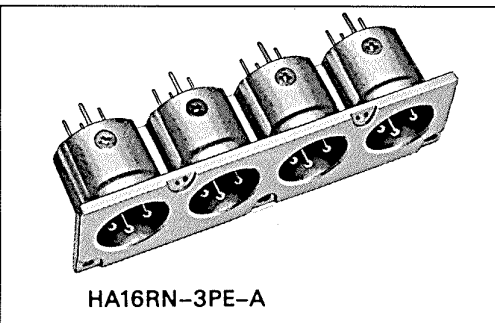

(An example in shape)

HRS No.	Part No.	No. of pin	Weight	Remarks
104-0442-2	HA16RN-3PE-A	3	50gr	4 chain type

(Plug-Receptacle Solder Type)

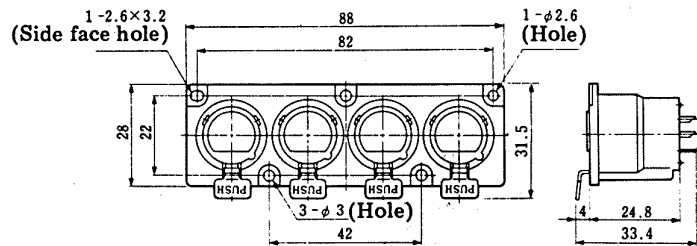
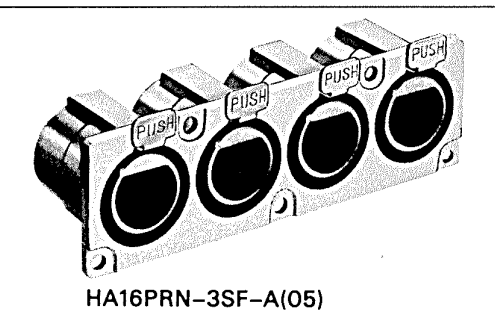

(An example in shape)

HRS No.	Part No.	No. of pin	Weight	Remarks
104-0423-8-05	HA16PRN-3SF-A(05)	3	80gr	4 chain type

(Plug-Receptacle PCB Dip Type)

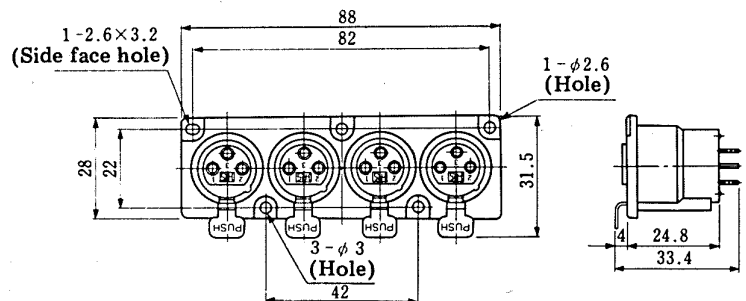
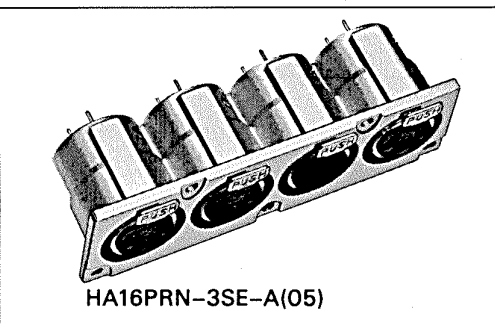

(An example in shape)

HRS No.	Part No.	No. of pin	Weight	Remarks
104-0441-0-05	HA16PRN-3SE-A(05)	3	68gr	4 chain type

Gang Type

(Plug-Receptacle, Receptacle Solder Type)

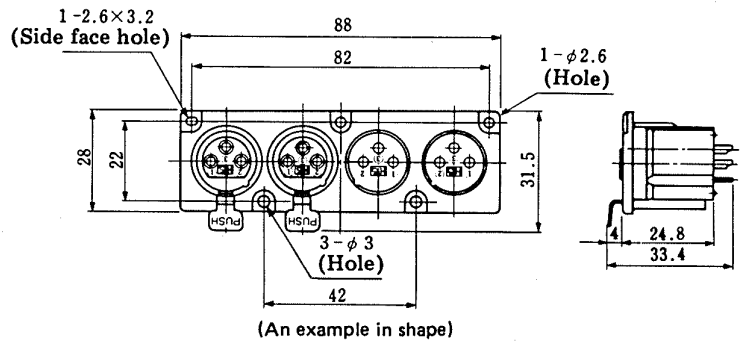
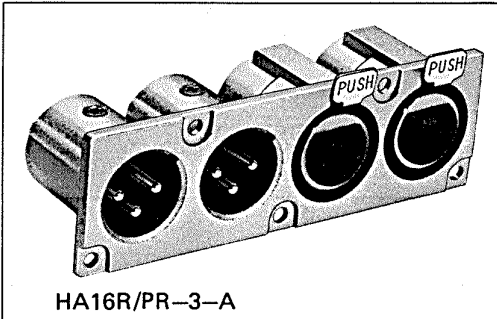

HRS No.	Part No.	No. of pin	Weight	Remarks
104-0446-3	HA16R/PR-3-A	3	66gr	4 chain type

(Plug-Receptacle Solder Type)

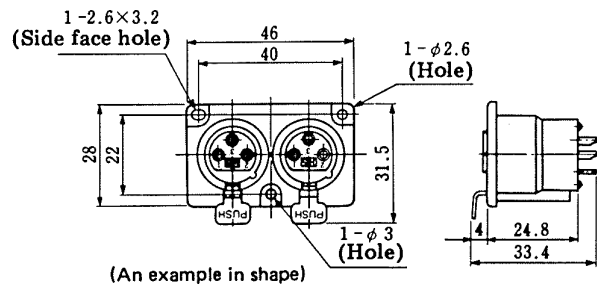
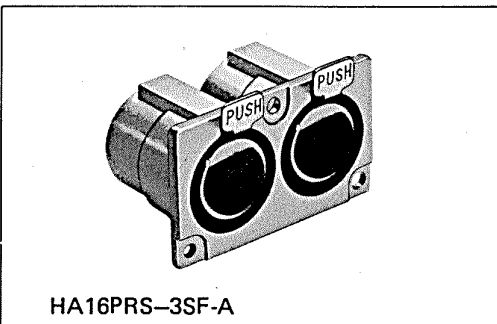

HRS No.	Part No.	No. of pin	Weight	Remarks
104-0452-6	HA16PRS-3SF-A	3	38gr	2 chain type

Pin Mold

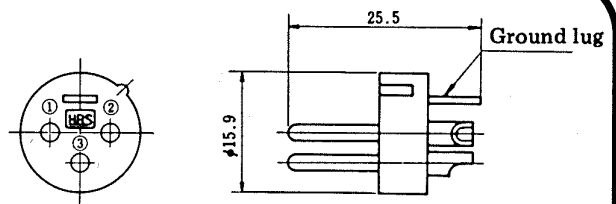
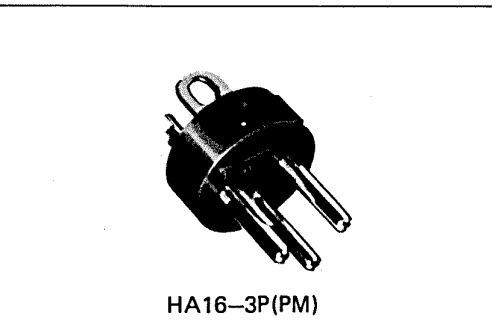

(An example in shape)

HRS No.	Part No.	No. of pin	Weight	Remarks
104-0355-0	HA16-3P(PM)	3	5gr	With ground lug M2.6 x 0.45 screw

High Sound Quality Connector

Ultra-high-fidelity audio units used by studio professionals employ cables of 6N or 8N high-purity oxygen-free copper for connecting the units which are designed to produce

sound of the highest quality. This connector is an ultra-high-fidelity type specially designed for extraordinary audio performance.

Plug

(Rubber Insert Type)

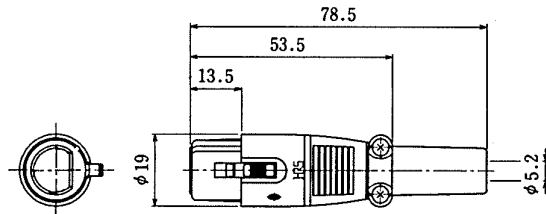
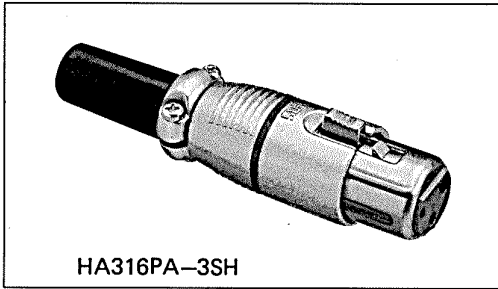

HRS No.	Part No.	No. of pins	Weight	Remarks
104-1202-4	HA316PA-3SH	3	45gr	Gold-plated (Non-magnetic material)

Jack

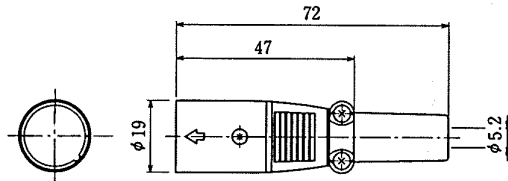
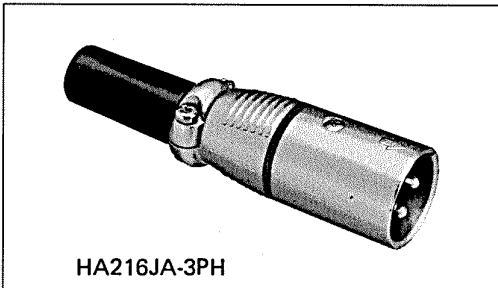

HRS No.	Part No.	No. of pins	Weight	Remarks
104-1222-1	HA216JA-3PH	3	45gr	Gold-plated (Non-magnetic material)

Receptacle

(Medium Size Flange Type)

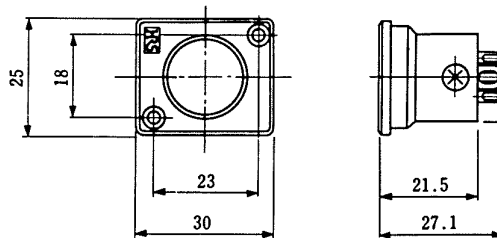
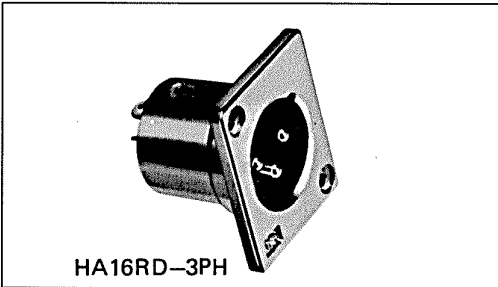

HRS No.	Part No.	No. of pins	Weight	Remarks
104-1212-8	HA16RD-3PH	3	45gr	Gold-plated (Non-magnetic material)

Plug-Receptacle

(Small Flange Type, Rubber Insert)

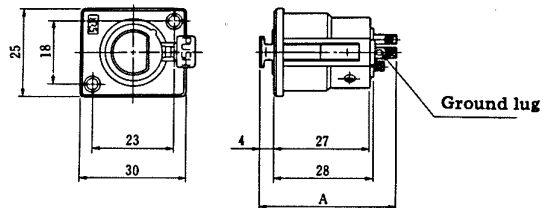
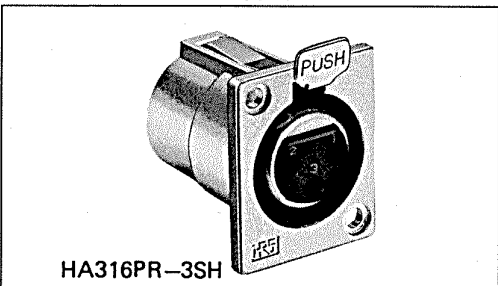

HRS No.	Part No.	No. of pins	Weight	Remarks
104-1231-2	HA316PR-3SH	3	45gr	Gold-plated (Non-magnetic material)

Panel Cutout

- Receptacle (Large Flange Type)

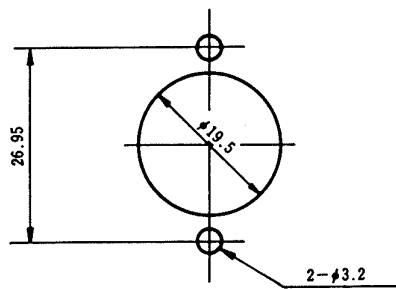

- (Middle Flange Type)

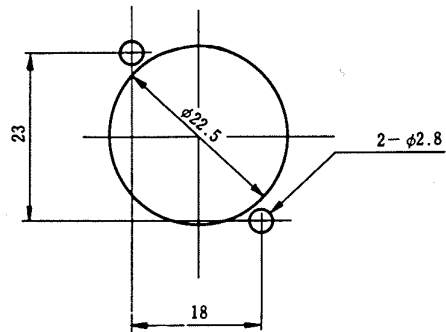

- (Small Flange Type)

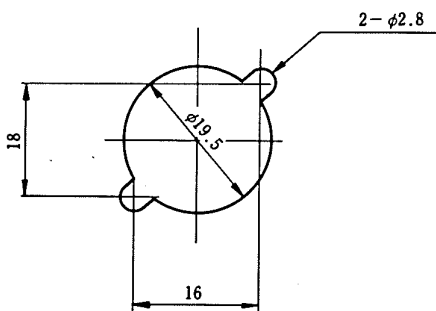

- (Inside Mount Type)

- HA16RM

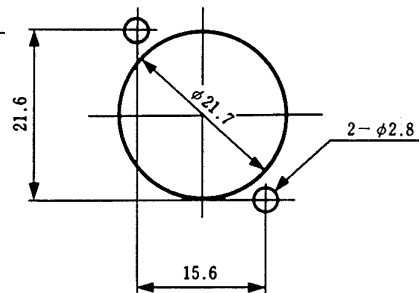

- HA16RY

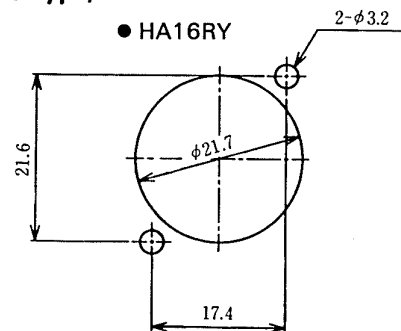

- Plug Receptacle (Small Flange Type)

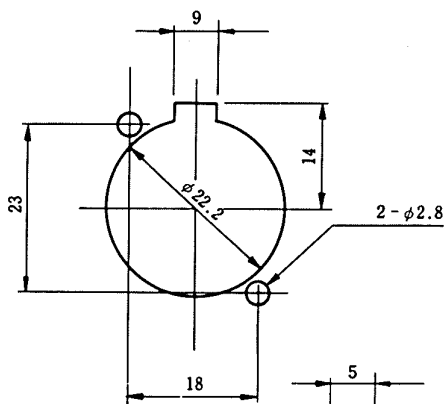

- (Inside Mount Type)

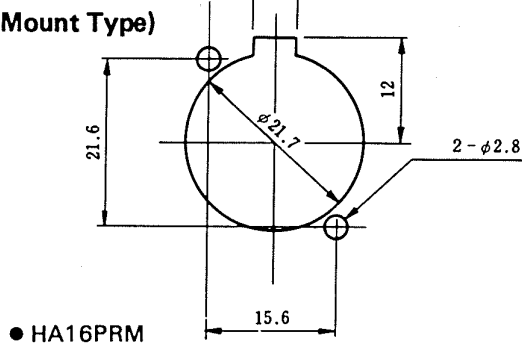

- HA16PRM

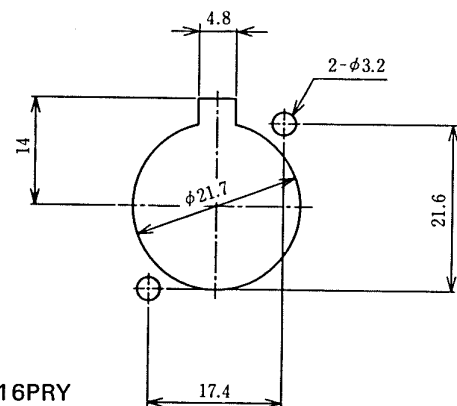

- HA16PRY

Panel Cutout

- Gang Type (Receptacle)

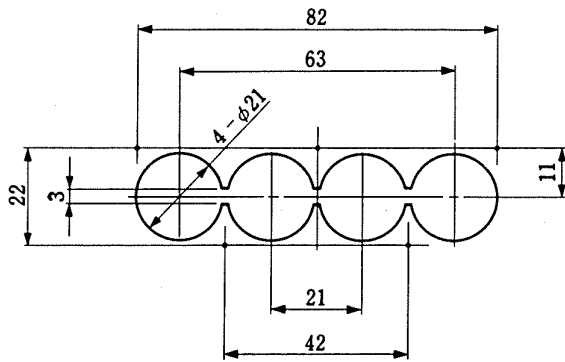

- (Plug-Receptacle)

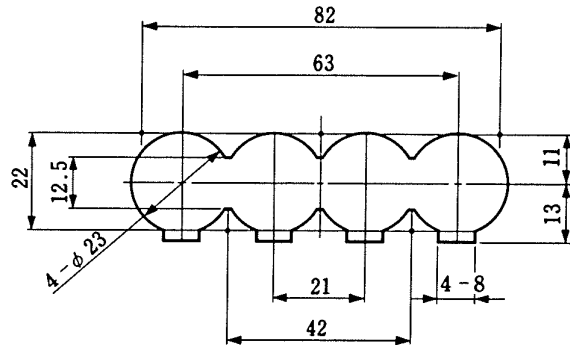

- (Plug-Receptacle, Receptacle)

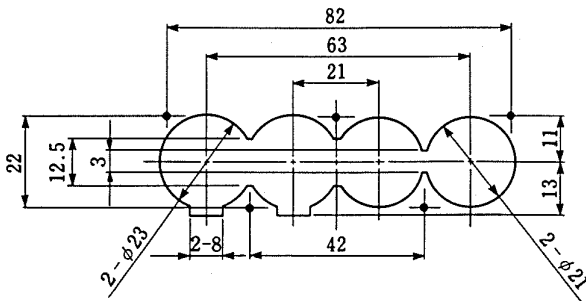

- (Plug-Receptacle)

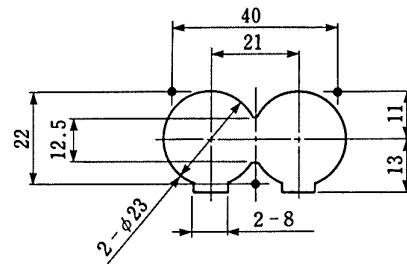

- Pin Mold

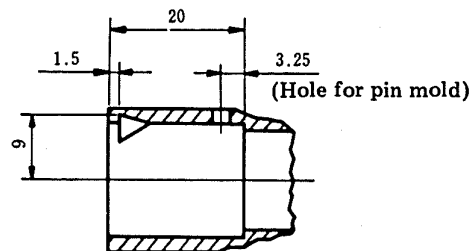
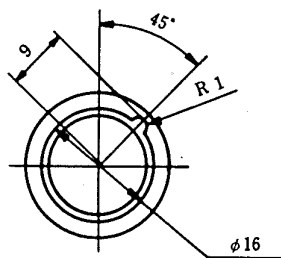

Dip Post Layout

The figure below shows the board surface in which connector terminal dip posts are to be inserted.

● Dip post right turn type

- HA16RM-3PA

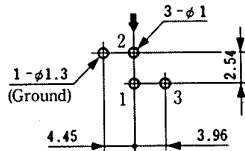

● Dip post down turn type

- HA16RM-3PB

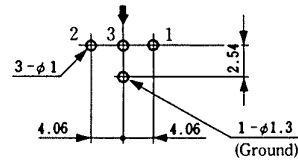

● Dip post left turn type

- HA16RM-3PD

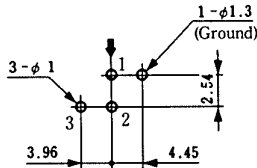

● Dip post straight type (As viewed from the mating surface)

- HA16RM-3PE

- HA16RN-3PE-A

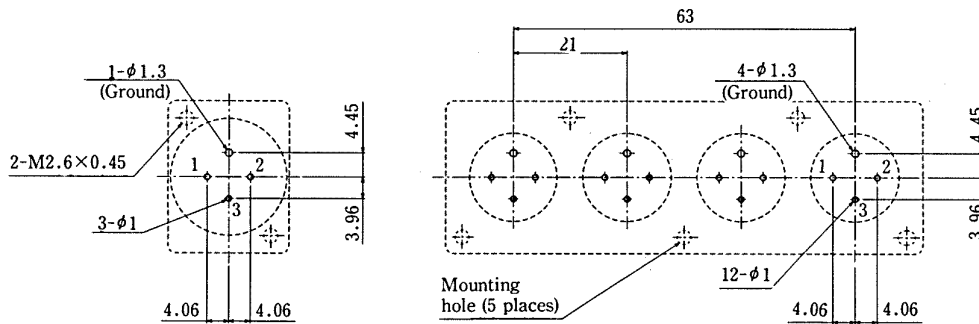

- HA16RY-3PE

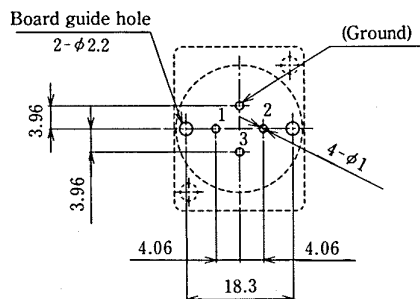

Dip Post Layout

● Dip post right turn type

- HA16PRM-3SA(05)

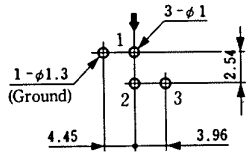

● Dip post down turn type

- HA16PRM-3SB(05)

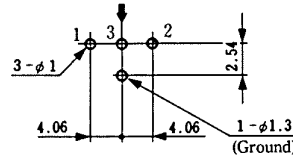

● Dip post left turn type

- HA16PRM-3SD(05)

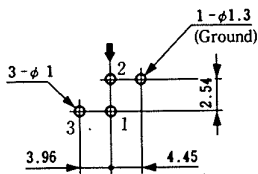

● Dip post straight type (As viewed from the mating surface)

- HA16PRM-3SE(05)

- HA16PRN-3SE-A

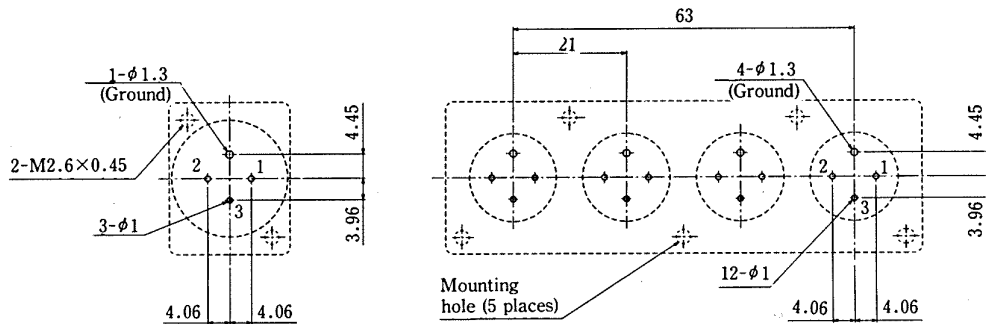

- HA16PRY-3SE

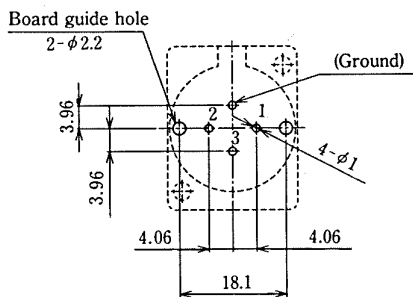

- Note 1: The arrow sign ↓ shows the mating direction of the applicable connector. Note that it is different from the direction of the mating guide key on a circuit board.
- Note 2: Recommended tolerance for the dip post layout is ± 0.05 .

Coupling Combination

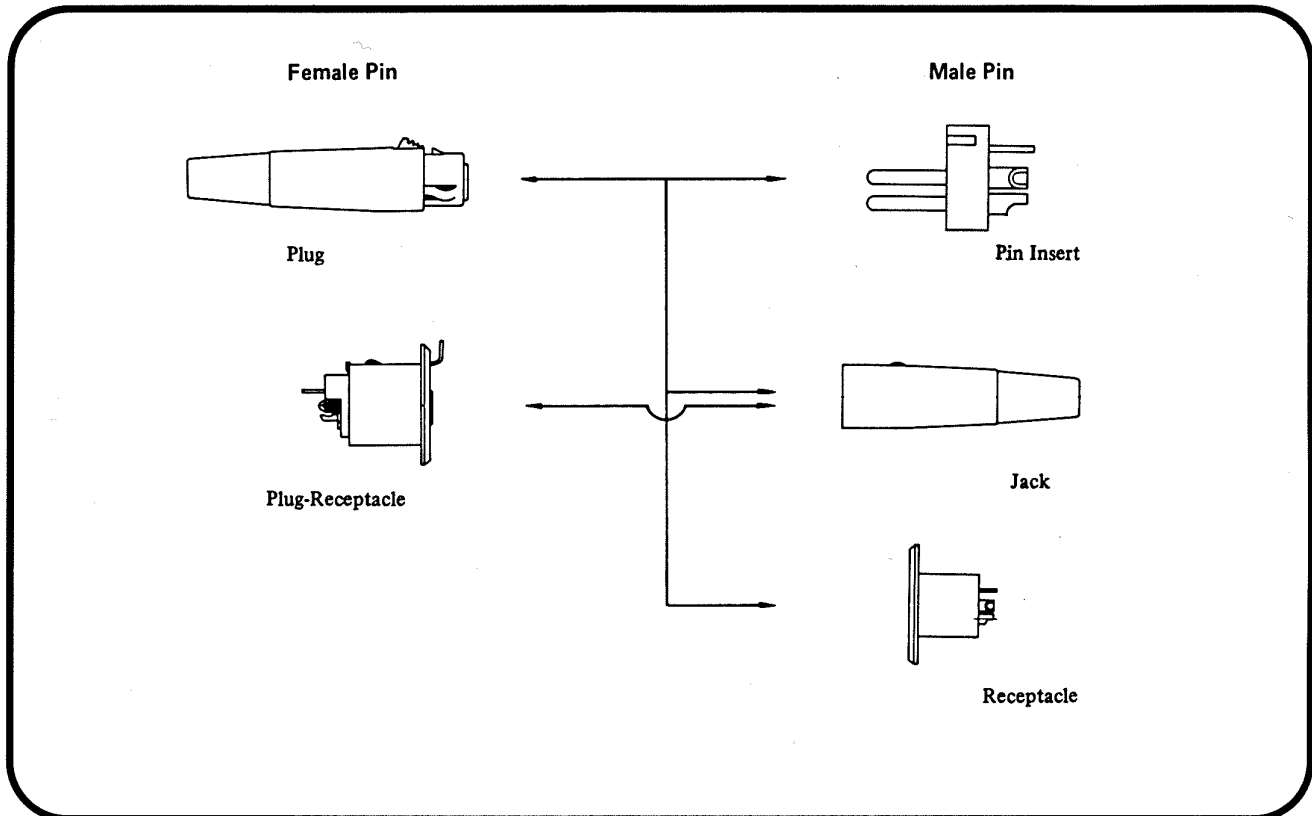

Assembling Procedure (HA16 Type Plug)

- Please follow same procedure in case of Jack.

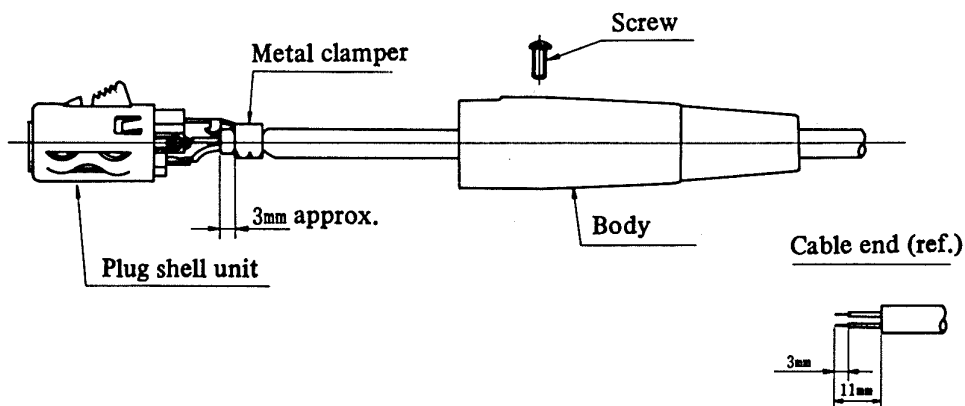

1. Please choose a cable of which the outside diameter is 4-6mm.
 2. Strip insulation of the cable end in the size as shown above.
 3. Solder the cable to plug shell.
 4. Crimp cable clamper, which holds cable, with a tool.
 5. Fit the P shell unit to the cord tube, and tighten the locking screw with a Torque of 0.3-0.4N-m (3.5-4kg-cm) to complete the work.
- For details, contact our sales or engineering department before using the model HA16 plugs.

Terminal arrangement and main performance

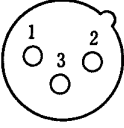
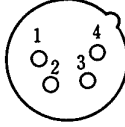
Terminal arrangement		
No. of pins	3	
Withstanding voltage	AC1400V a minute	
Current rating	15A	3A (Board dip type)
Insulation resistance	1000MΩ MIN.	
Contact resistance	5mΩ MAX.	10mΩ MAX.

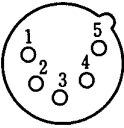
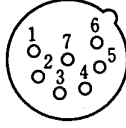
Terminal arrangement		
No. of pins	5	7
Withstanding voltage	AC1400 a minute	AC1400V a minute
Current rating	4A (7.5A)	5A
Insulation resistance	1000MΩ MIN.	1000MΩ MIN.
Contact resistance	10mΩ MAX.	10mΩ MAX.

- Note
1. The above figures show the receptacle pin inserts as viewed from the mating side.
 2. The withstand voltages show test voltages.
 3. The insulation resistances show the values at 500VDC.
 4. The contact resistance show the values at 1ADC.
 5. The current rating of 7.5A in for HA316 only.