

HAT1007F

Silicon P Channel Power MOS FET

Application

Power switching
Synchronously Rectifier

Features

- Low on-resistance
- Capable of 4V gate drive
- Low drive current
- High density mounting

Ordering Information

Hitachi Code	FP-8D
EIAJ Code	SC-527-8A
JEDEC Code	—

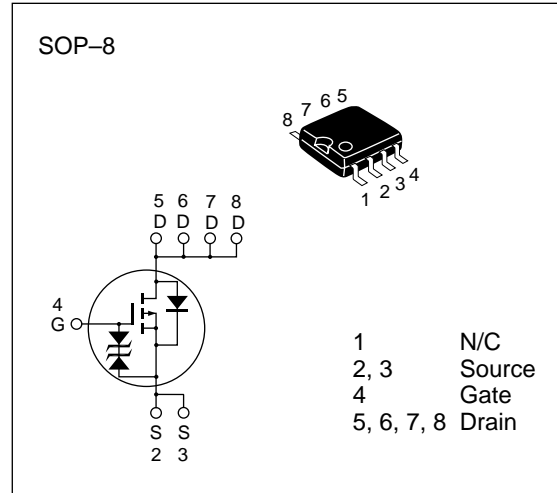

Table 1 Absolute Maximum Ratings (Ta = 25°C)

Item	Symbol	Ratings	Unit
Drain to source voltage	V _{DSS}	-20	V
Gate to source voltage	V _{GSS}	±20	V
Drain current	I _D	-3.5	A
Drain peak current	I _{D(pulse)} *	-15	A
Body-drain diode reverse drain current	I _{DR}	-3.5	A
Channel dissipation	P _{ch} **	1.0	W
Channel temperature	T _{ch}	150	°C
Storage temperature	T _{stg}	-55 to +150	°C

* PW ≤ 10 μs, duty cycle ≤ 1 %

** When using the glass epoxy board (40 x 40 x 1.6 mm)

Table 2 Electrical Characteristics (Ta = 25°C)

Item	Symbol	Min	Typ	Max	Unit	Test conditions
Drain to source breakdown voltage	$V_{(BR)DSS}$	-20	—	—	V	$I_D = -10 \text{ mA}$, $V_{GS} = 0$
Gate to source breakdown voltage	$V_{(BR)GSS}$	± 20	—	—	V	$I_G = \pm 100 \text{ }\mu\text{A}$, $V_{DS} = 0$
Gate to source leak current	I_{GSS}	—	—	± 10	μA	$V_{GS} = \pm 16 \text{ V}$, $V_{DS} = 0$
Zero gate voltage drain current	I_{DSS}	—	—	-10	μA	$V_{DS} = -20 \text{ V}$, $V_{GS} = 0$
Gate to source cutoff voltage	$V_{GS(off)}$	-1.0	—	-2.5	V	$V_{DS} = -10 \text{ V}$, $I_D = -1 \text{ mA}$
Static drain to source on state resistance	$R_{DS(on)}$	—	0.06	0.08	Ω	$I_D = -2 \text{ A}$ $V_{GS} = -10 \text{ V}^*$
		—	0.1	0.15	Ω	$I_D = -2 \text{ A}$ $V_{GS} = -4 \text{ V}^*$
Forward transfer admittance	$ y_{fs} $	3.0	5.0	—	S	$I_D = -2 \text{ A}$ $V_{DS} = -10 \text{ V}^*$
Input capacitance	C_{iss}	—	730	—	pF	$V_{DS} = -10 \text{ V}$
Output capacitance	C_{oss}	—	680	—	pF	$V_{GS} = 0$
Reverse transfer capacitance	C_{rss}	—	250	—	pF	$f = 1 \text{ MHz}$
Turn-on delay time	$t_{d(on)}$	—	28	—	ns	$V_{GS} = -4 \text{ V}$, $I_D = -2 \text{ A}$
Rise time	t_r	—	165	—	ns	$V_{DD} = -10 \text{ V}$
Turn-off delay time	$t_{d(off)}$	—	45	—	ns	
Fall time	t_f	—	95	—	ns	
Body-drain diode forward voltage	V_{DF}	—	-0.9	—	V	$I_F = -3.5 \text{ A}$, $V_{GS} = 0$
Body-drain diode reverse recovery time	t_{rr}	—	75	—	ns	$I_F = -3.5 \text{ A}$, $V_{GS} = 0$ $di_F / dt = 20 \text{ A} / \mu\text{s}$

* Pulse Test

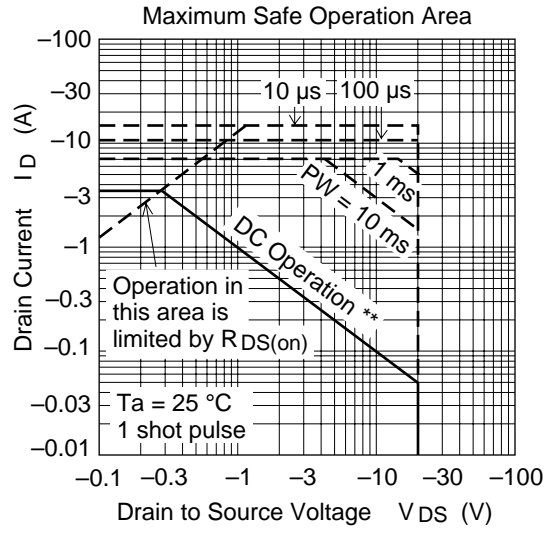
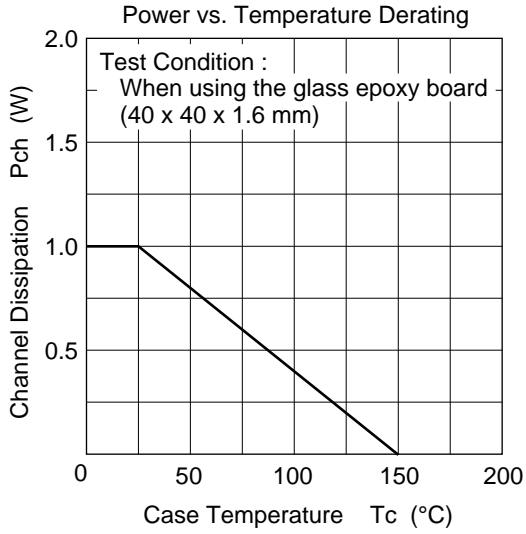

** When using the glass epoxy board
(40 x 40 x 1.6 mm)

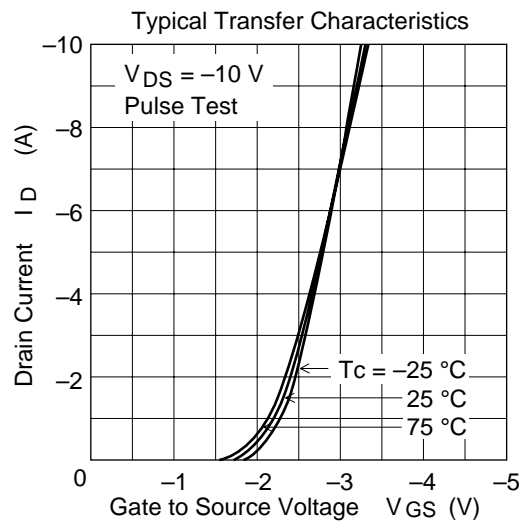
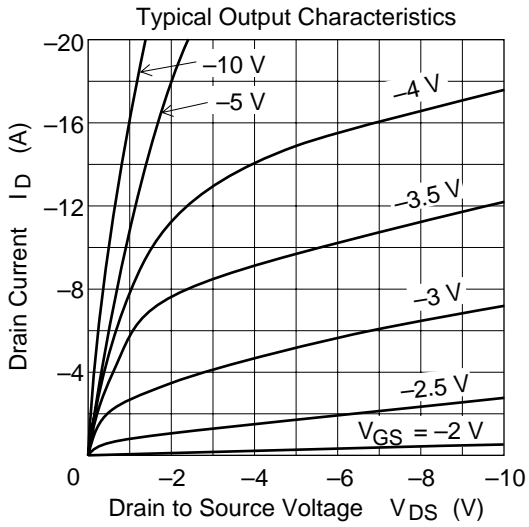

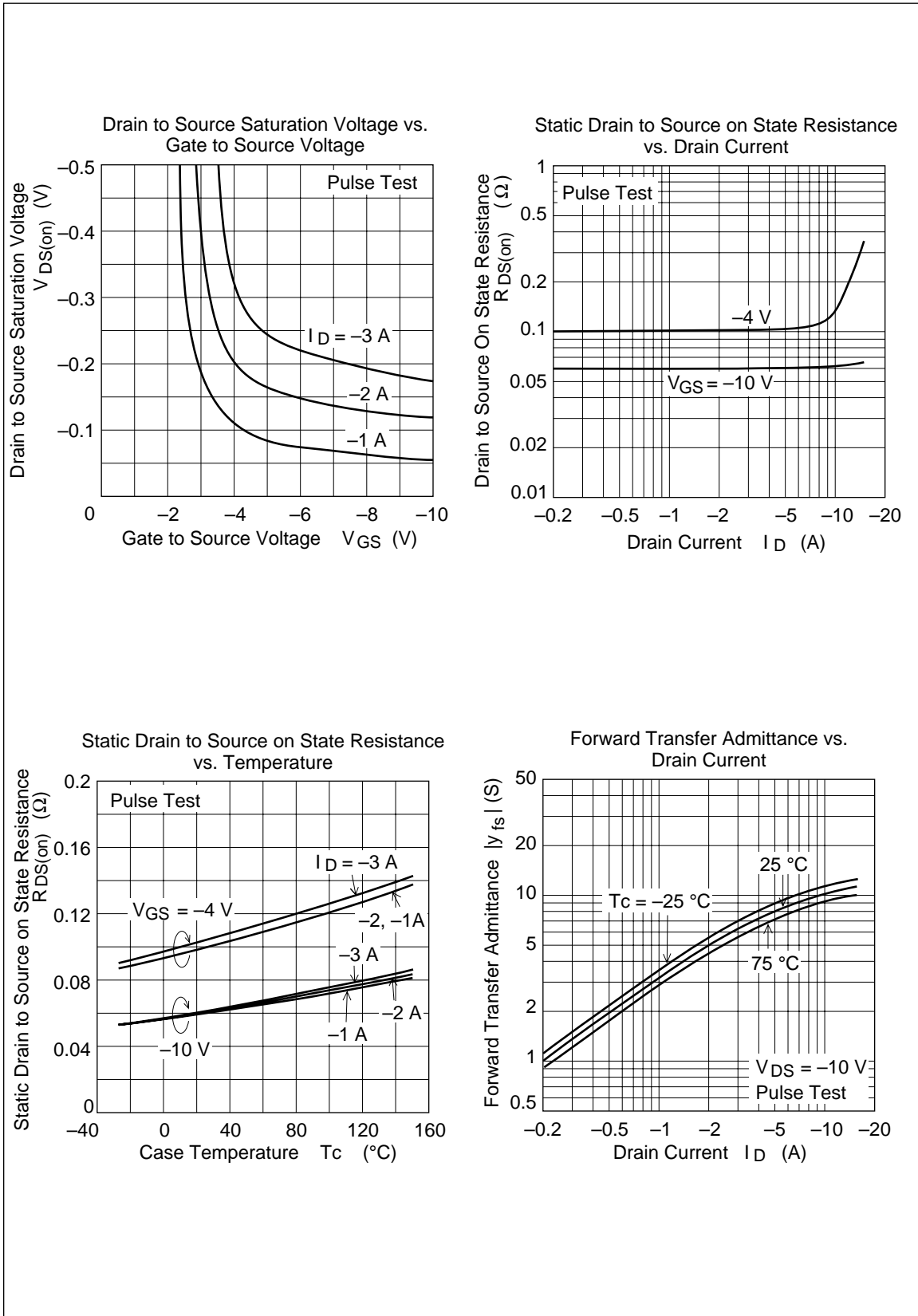

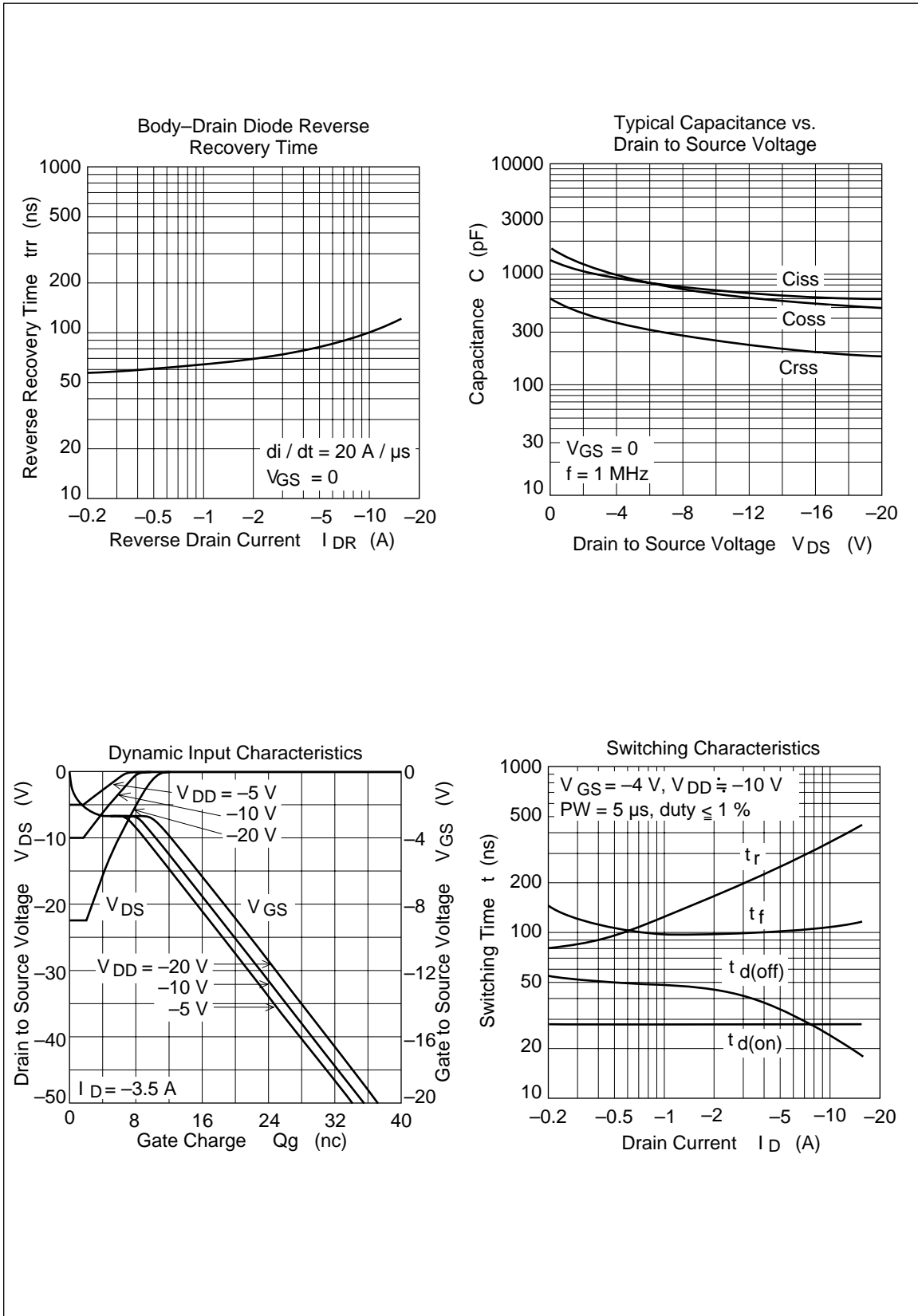

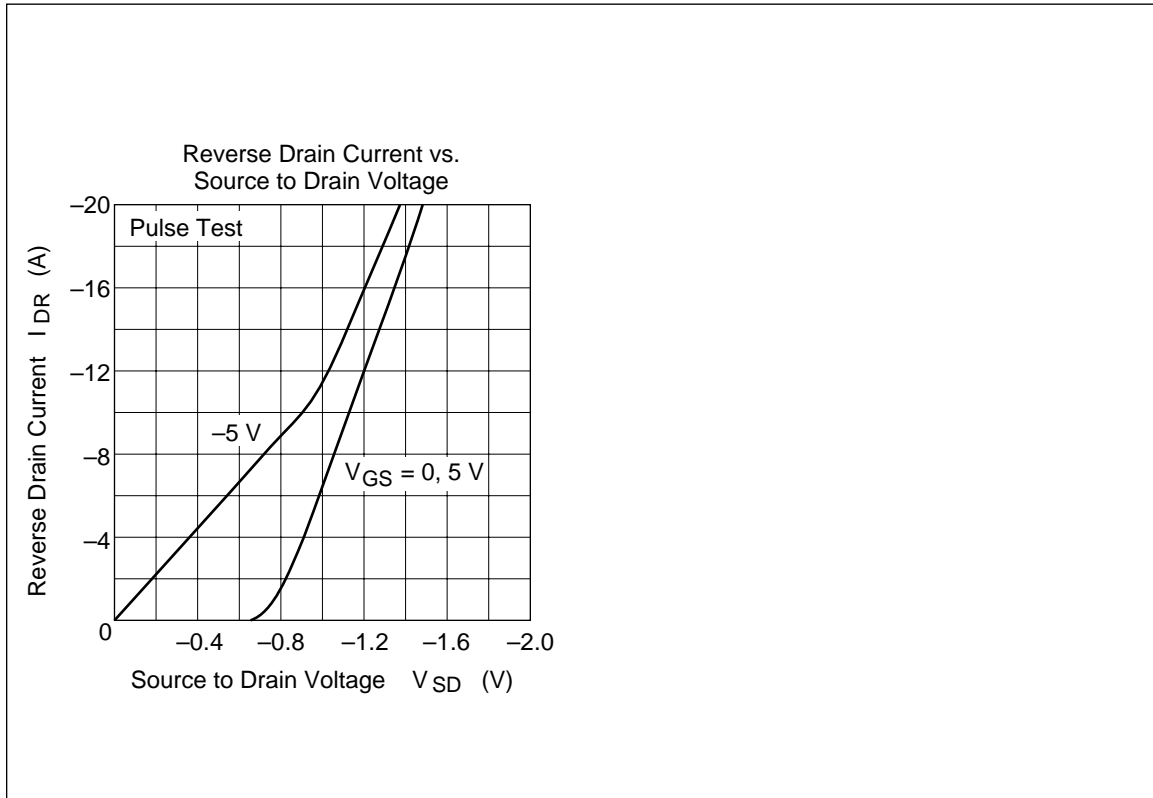

Package Dimensions

Unit : mm

