

4 x 4 MULTIPOINT REGISTER

- FOUR 4-BIT REGISTERS
- ONE INPUT AND TWO OUTPUT BUSES
- UNLIMITED EXPANSION IN BIT AND WORD DIRECTION
- DATA LINES HAVE LATCHED INPUTS
- 3-STATE OUTPUTS
- SEPARATE CONTROL OF EACH BUS, ALLOWING SIMULTANEOUS INDEPENDENT READING AND ANY OF FOUR REGISTERS ON BUS A AND BUS B AND INDEPENDENT WRITING INTO ANY ANY OF THE FOUR REGISTERS
- 40108B IS PIN COMPATIBLE WITH INDUSTRY TYPE MC14580
- STANDARDIZED, SYMMETRICAL OUTPUT CHARACTERISTICS
- QUIESCENT CURRENT SPECIFIED AT 20V FOR HCC DEVICE
- 5V, 10V AND 15V PARAMETRIC RATINGS
- INPUT CURRENT OF 100 nA AT 18V AND 250C FOR HCC DEVICE
- 100% TESTED FOR QUIESCENT CURRENT
- MEETS ALL REQUIREMENTS OF JEDEC TENTATIVE STANDARD No 13a, "STANDARD SPECIFICATIONS FOR DESCRIPTION OF B SERIES CMOS DEVICES"

DESCRIPTION

The HCC40108B (extended temperature range) and HCF40108B (intermediate temperature range) are monolithic integrated circuits, available in 24 lead dual in line plastic or ceramic package and plastic micropackage. The HCC/HCF40108B is a 4 X 4 multipoint register containing four 4-bit register, write address decoder, two separate read address decoders, and two 3-state output buses. When the ENABLE input is low, the corresponding output bus is switched, independently of the clock, to a high impedance state. The high impedance third state provides the outputs with the capability of being connected to the bus lines in a bus organized system without the need for interface or pull-up components. When the WRITE ENABLE input is high, all data input lines are latched on the positive transition of the CLOCK and the data is entered into the word selected by the write address lines. When WRITE ENABLE is low, the CLOCK is inhibited and

no new data is entered. In either case, the contents of any word may be accessed via the read address lines independent of the state of the CLOCK input.

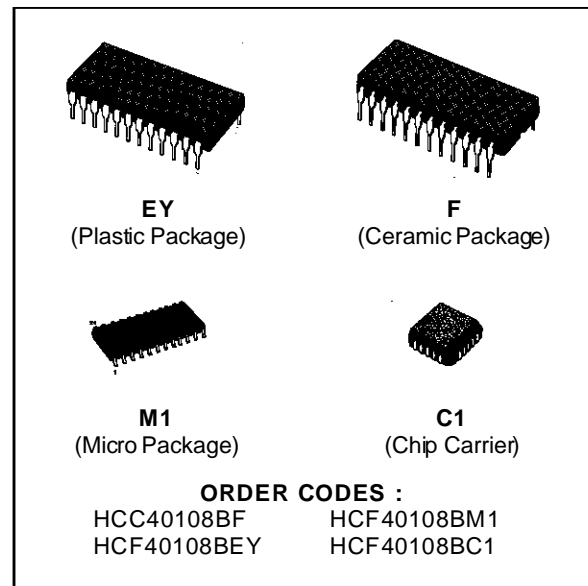

PIN CONNECTIONS

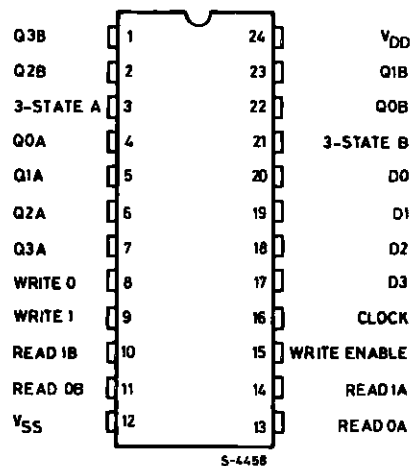

FUNCTIONAL DIAGRAM

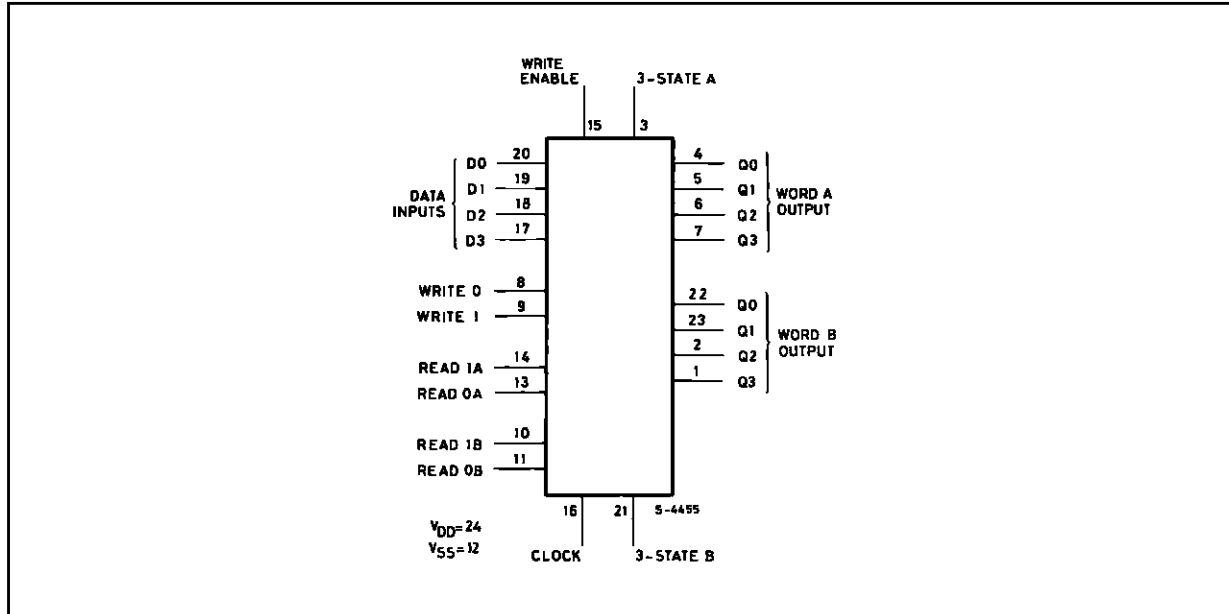

LOGIC DIAGRAM

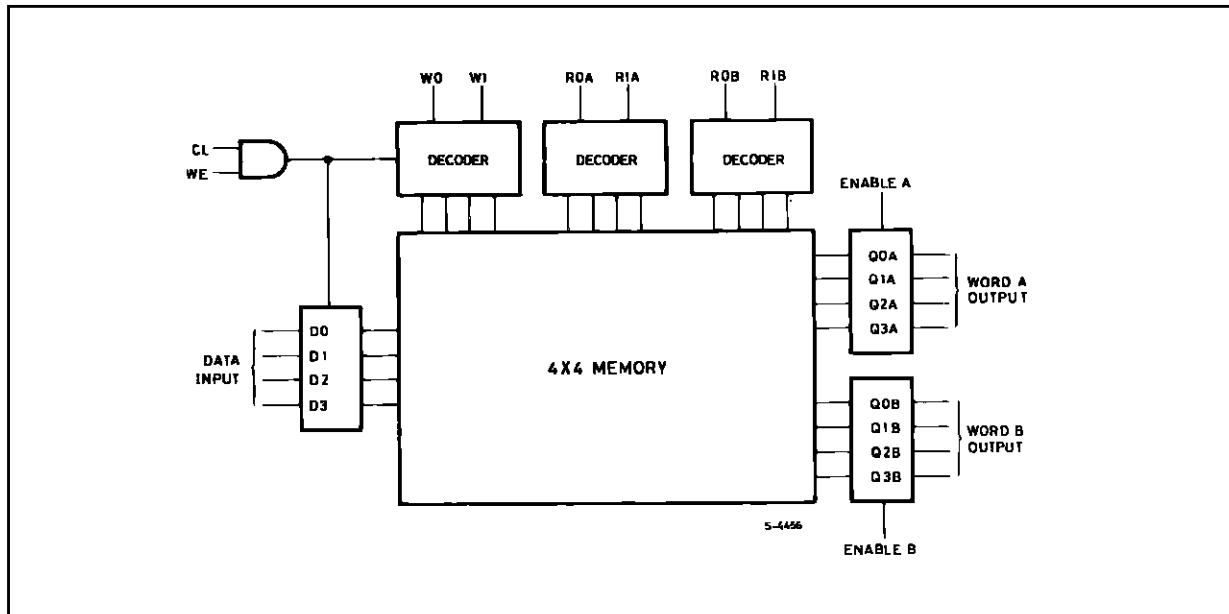

ABSOLUTE MAXIMUM RATING

Symbol	Parameter	Value	Unit
V _{DD} *	Supply Voltage: HCC Types HCF Types	-0.5 to +20	V
		-0.5 to +18	V
V _i	Input Voltage	-0.5 to V _{DD} + 0.5	V
I _I	DC Input Current (any one input)	± 10	mA
P _{tot}	Total Power Dissipation (per package) Dissipation per Output Transistor for Top = Full Package Temperature Range	200	mW
		100	mW
T _{op}	Operating Temperature: HCC Types HCF Types	-55 to +125	°C
		-40 to +85	°C
T _{stg}	Storage Temperature	-65 to +150	°C

Stresses above those listed under "Absolute Maximum Ratings" may cause permanent damage to the device. This is a stress rating only and functional operation of the device at these or any other conditions above those indicated in the operational sections of this specification is not implied. Exposure to absolute maximum rating conditions for external periods may affect device reliability.

* All voltage values are referred to V_{SS} pin voltage.

RECOMMENDED OPERATING CONDITIONS

Symbol	Parameter	Value	Unit
V _{DD}	Supply Voltage: HCC Types HCF Types	3 to 18	V
		3 to 15	V
V _i	Input Voltage	0 to V _{DD}	V
T _{op}	Operating Temperature: HCC Types HCF Types	-55 to +125	°C
		-40 to +85	°C

TRUTH TABLE

CLOCK	Write Enable	Write 1	Write 2	Read 1A	Read 0A	Read 1B	Read 0B	Enable A	Enable B	D _n	Q _{nA}	Q _{nB}
	1	S1	S2	S1	S2	S1	S2	1	1	1	1	1
	1	S1	S2	S1	S2	S1	S2	1	0	0	0	0
X	X	X	X	X	X	X	X	0	X	Z	Z	Z
	1	0	0	0	1	1	0	1	1	D _n to word 0	Word 1 Out	Word 2 Out
	0	0	0	0	1	1	0	1	1	Word 0 not altered	Word 1 Out	Word 2 Out
X	X	X	X	1	0	0	1	1	X	X	Word 2 Out	Word 1 Out
	X	X	X	X	X	X	X	1	1	X	NC	NC

1 = HIGH LEVEL, 0 = LOW LEVEL, X = DONT CARE, Z = HIGH IMPEDANCE

S1 and S2 refer to input strates of either 1 or 0

SCHEMATIC DIAGRAM

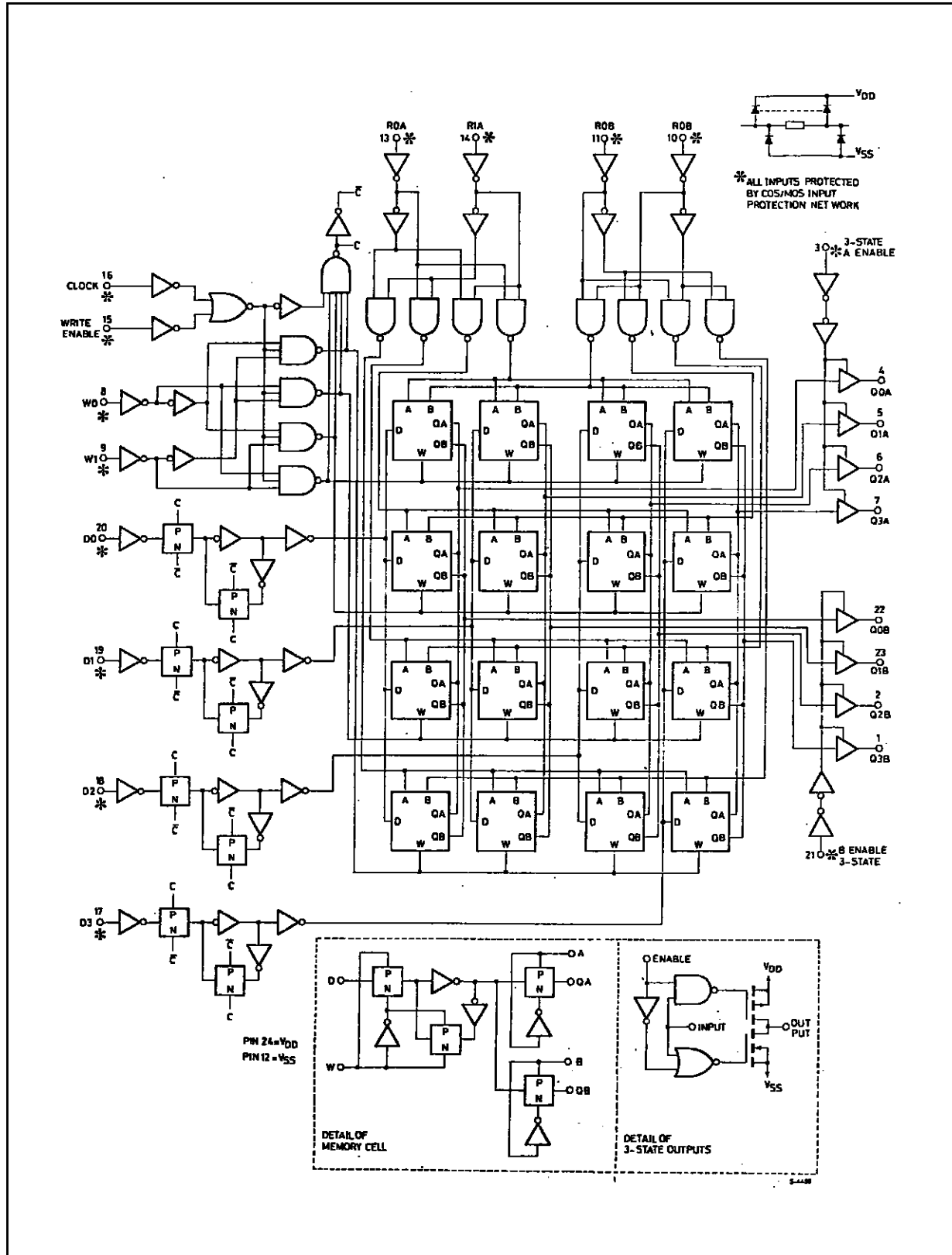

STATIC ELECTRICAL CHARACTERISTICS (over recommended operating conditions)

Symbol	Parameter		Test Conditions				Value						Unit	
			V _I (V)	V _O (V)	I _O (μ A)	V _{DD} (V)	T _{LOW} *		25 °C			T _{HIGH} *		
							Min.	Max.	Min.	Typ.	Max.	Min.		Max.
I _L	Quiescent Current	HCC Types	0/5			5		5		0.04	5		150	μ A
			0/10			10		10		0.04	10		300	
			0/15			15		20		0.04	20		600	
		0/20			20		100		0.08	100		3000		
		HCF Types	0/5			5		20		0.04	20		150	
			0/10			10		40		0.04	40		300	
0/15				15		80		0.04	80		600			
V _{OH}	Output High Voltage	0/5		< 1	5	4.95		4.95			4.95		V	
		0/10		< 1	10	9.95		9.95			9.95			
		0/15		< 1	15	14.95		14.95			14.95			
V _{OL}	Output Low Voltage	5/0		< 1	5		0.05			0.05		0.05	V	
		10/0		< 1	10		0.05			0.05		0.05		
		15/0		< 1	15		0.05			0.05		0.05		
V _{IH}	Input High Voltage	0/5	0.5/4.5	< 1	5	3.5		3.5			3.5		V	
		0/10	1/9	< 1	10	7		7			7			
		0/15	1.5/13.5	< 1	15	11		11			11			
V _{IL}	Input Low Voltage	0/5	4.5/0.5	< 1	5		1.5			1.5		1.5	V	
		0/10	9/1	< 1	10		3			3		3		
		0/15	13.5/1.5	< 1	15		4			4		4		
I _{OH}	Output Drive Current	HCC Types	0/5	2.5		5	-2		-1.6	-3.2		-1.15	mA	
			0/5	4.6		5	-0.64		-0.51	-1		-0.36		
			0/10	9.5		10	-1.6		-1.3	-2.6		-0.9		
			0/15	13.5		15	-4.2		-3.4	-6.8		-2.4		
		HCF Types	0/5	2.5		5	-1.53		-1.36	-3.2		-1.1		
			0/5	4.6		5	-0.52		-0.44	-1		-0.36		
			0/10	9.5		10	-1.3		-1.1	-2.6		-0.9		
			0/15	13.5		15	-3.6		-3.0	-6.8		-2.4		
I _{OL}	Output Sink Current	HCC Types	0/5	0.4		5	0.64		0.51	1		0.36	mA	
			0/10	0.5		10	1.6		1.3	2.6		0.9		
			0/15	1.5		15	4.2		3.4	6.8		2.4		
		HCF Types	0/5	0.4		5	0.52		0.44	1		0.36		
			0/10	0.5		10	1.3		1.1	2.6		0.9		
			0/15	1.5		15	3.6		3.0	6.8		2.4		
I _{IH} , I _{IL}	Input Leakage Current	HCC Types	0/18	Any Input		18		± 0.1		$\pm 10^{-5}$	± 0.1		± 1	μ A
		HCF Types	0/15			15		± 0.3		$\pm 10^{-5}$	± 0.3		± 1	
I _{OH} , I _{OL} **	3-State Output Leakage Current	HCC Types	0/18	0/18		18		± 0.4		$\pm 10^{-4}$	± 0.4		± 12	μ A
		HCF Types	0/15	0/15		15		± 1.0		$\pm 10^{-4}$	± 1.0		± 7.5	
C _I	Input Capacitance			Any Input					5	7.5			pF	

* T_{LOW} = -55 °C for HCC device; -40 °C for HCF device.* T_{HIGH} = +125 °C for HCC device; +85 °C for HCF device.The Noise Margin for both "1" and "0" level is: 1V min. with V_{DD} = 5V, 2V min. with V_{DD} = 10V, 2.5V min. with V_{DD} = 15V

** Forced output disable

HCC/HCF40108

DYNAMIC ELECTRICAL CHARACTERISTICS ($T_{amb} = 25\text{ }^{\circ}\text{C}$, $C_L = 50\text{ pF}$, $R_L = 200\text{ K}\Omega$, typical temperature coefficient for all V_{DD} values is $03\text{ } \%/^{\circ}\text{C}$, all input rise and fall times = 20 ns)

Symbol	Parameter	Test Conditions		Value			Unit
			V_{DD} (V)	Min.	Typ.	Max.	
t_{PLH} t_{PHL}	Propagation Delay Time Clock or Write Enable to Q		5		360	720	ns
			10		140	280	
			15		100	200	
	Propagation Delay Time Read or Write Address to Q		5		300	600	
			10		120	240	
			15		85	170	
t_{PZH} t_{PHZ}	3-State Disable Delay Time		5		100	200	ns
			10		50	100	
			15		40	80	
t_{PZL} t_{PLZ}	3-State Display Delay Time		5		130	260	ns
			10		60	120	
			15		50	100	
t_{TLH} t_{THL}	Output Transition Time		5		100	200	ns
			10		50	100	
			15		40	80	
t_{setup}	Setup Time Data to Clock $t_{s(D)}$		5	0	-95		ns
			10	0	-35		
			15	0	-20		
	Setup Time Write Enable to Clock $t_{s(WE)}$		5	250	125		
			10	100	50		
			15	70	35		
	Setup Time Write Address to Clock $t_{s(WA)}$		5	250	125		
			10	100	50		
			15	70	35		
t_r, t_s	Clock Rise and Fall Time		5			15	μs
			10			5	
			15			5	
t_{hold}	Hold Time Data to Clock $t_{s(D)}$		5	220	110		ns
			10	100	50		
			15	80	40		
	Hold Time Write Enable to Clock $t_{s(WE)}$		5	270	135		
			10	130	65		
			15	80	40		
	Hold Time Write Address to Clock $t_{s(WA)}$		5	330	165		
			10	140	70		
			15	90	45		
t_w	Clock Pulse Width Clock or Write Enable $t_{w(CL)}$		5	350	175		ns
			10	130	65		
			15	90	45		
	Clock Pulse Width Write Address $t_{w(WA)}$		5	300	150		
			10	150	75		
			15	90	45		
f_{CL}	Maximum Clock Input Frequency		5	1.5	3		MHz
			10	3.5	7		
			15	4.5	9		

Output Low (sink) Current Characteristics

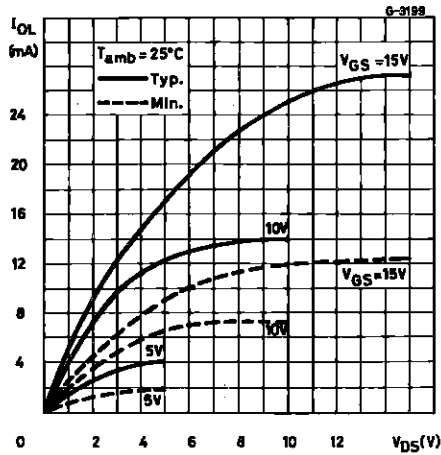

Output High (source) Current Characteristics

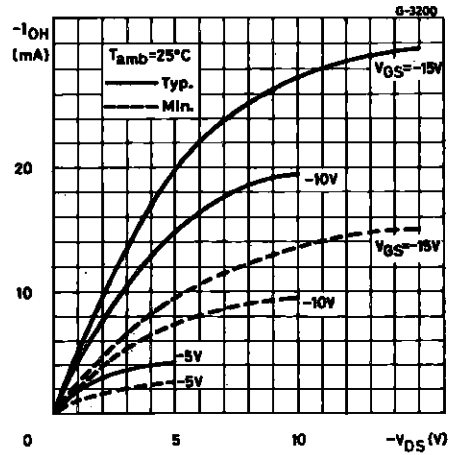

Typical Propagation Delay Time vs Load Capacitance (CL or WE to Q)

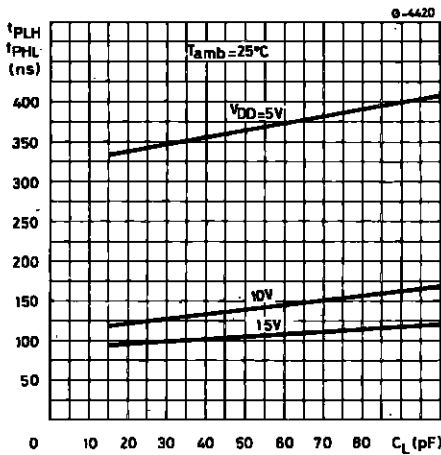

Typical Transition Time vs Load Capacitance

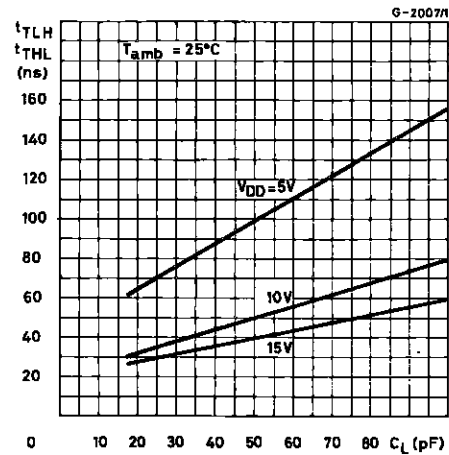

Typical Dynamic Power Dissipation vs Input Frequency

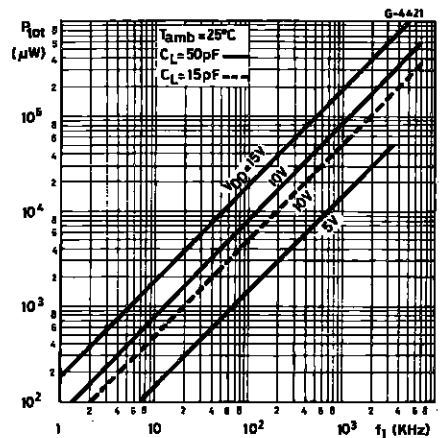

TIMING DIAGRAM

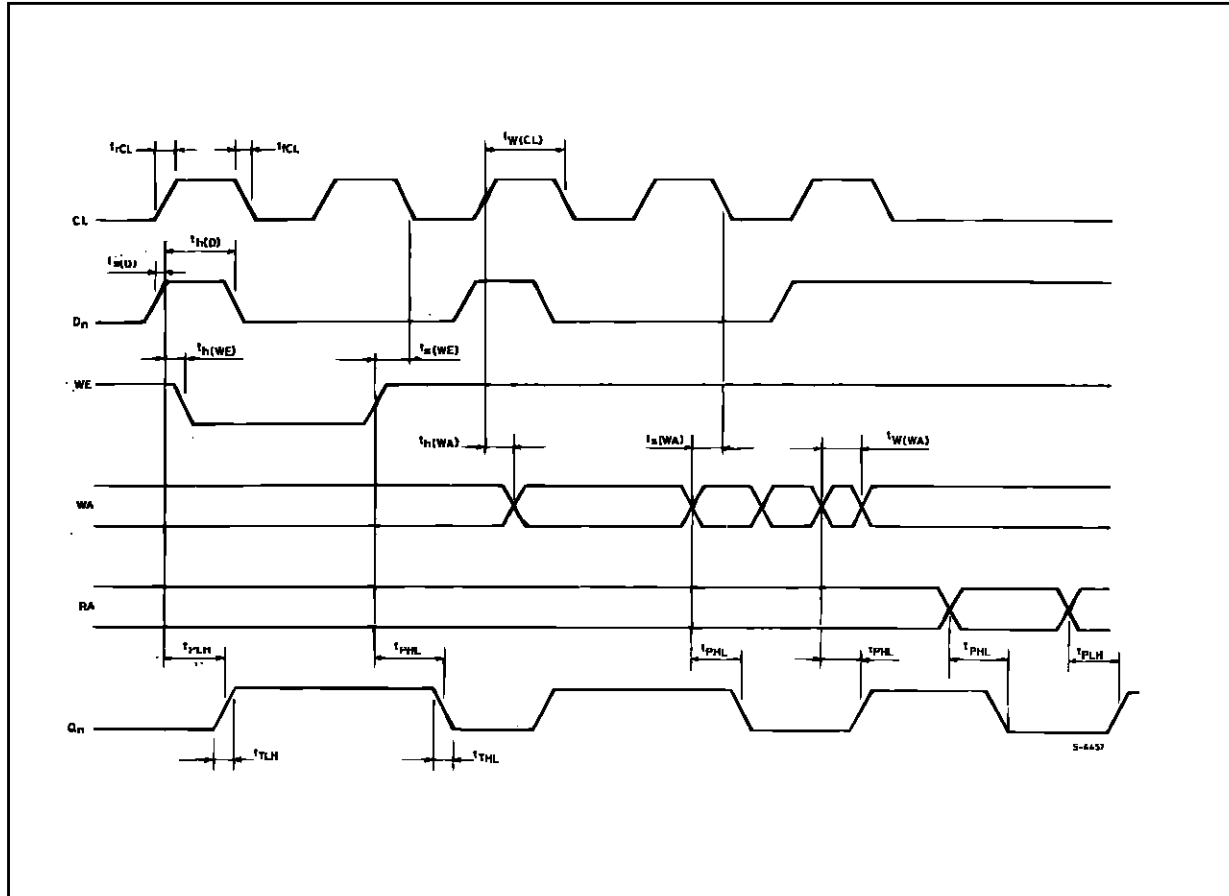

TEST CIRCUITS

Output Enable Delay Times and Waveforms

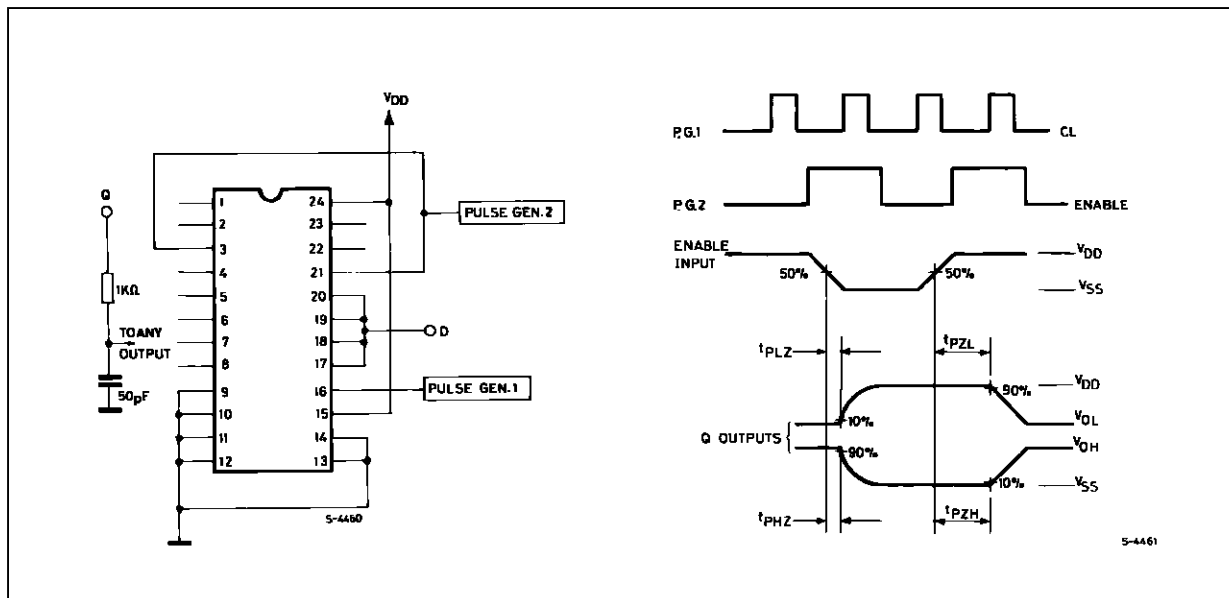

Power Dissipation and Waveforms

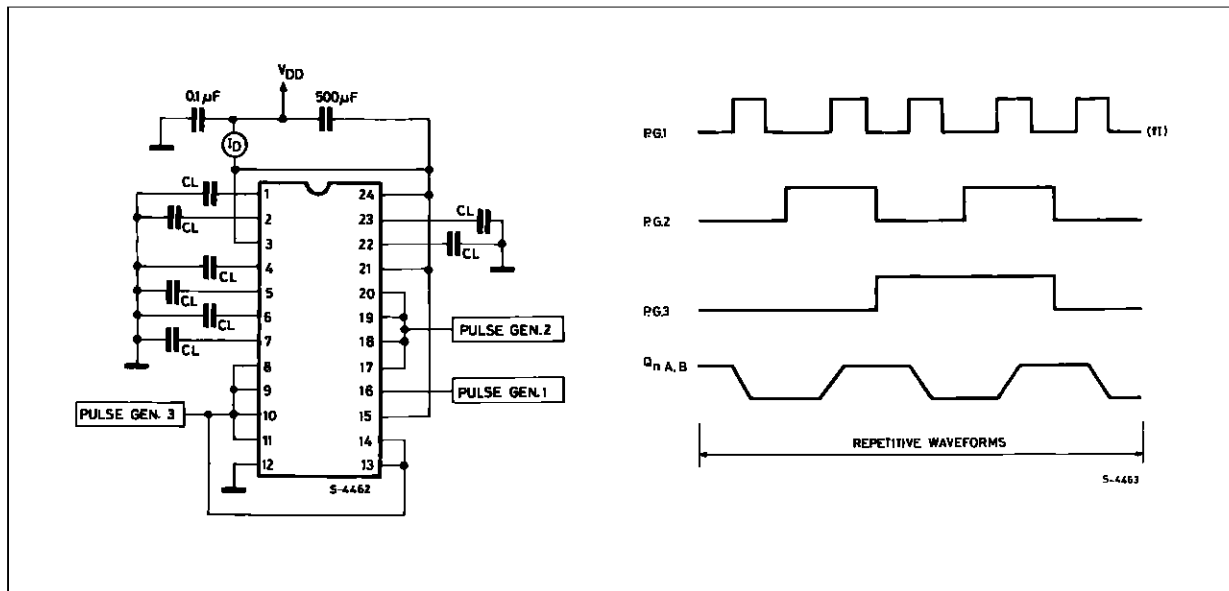

Quiescent Device Current

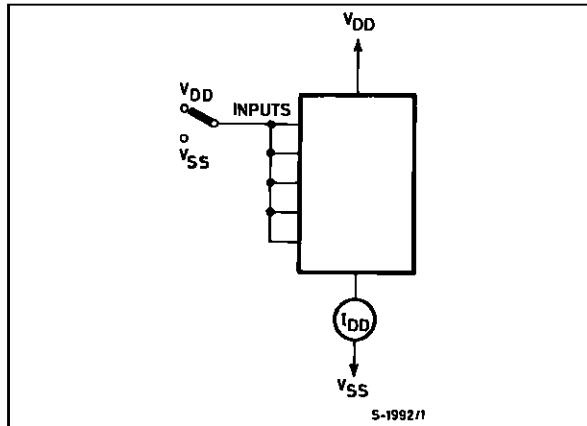

Noise Immunity

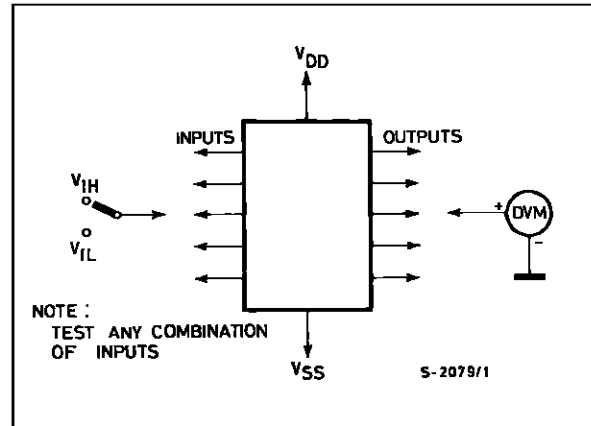

Input Leakage Current

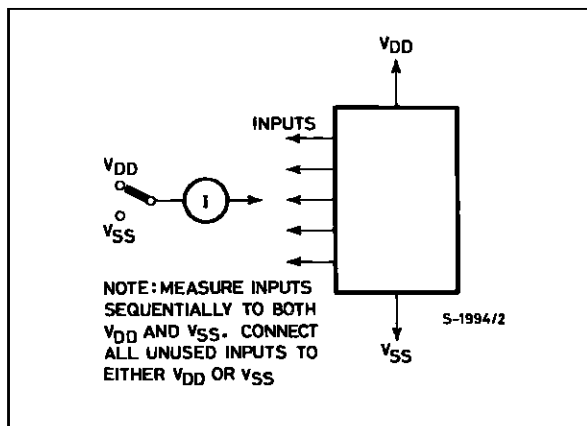

Plastic DIP24 (0.25) MECHANICAL DATA

DIM.	mm			inch		
	MIN.	TYP.	MAX.	MIN.	TYP.	MAX.
a1		0.63			0.025	
b		0.45			0.018	
b1	0.23		0.31	0.009		0.012
b2		1.27			0.050	
D			32.2			1.268
E	15.2		16.68	0.598		0.657
e		2.54			0.100	
e3		27.94			1.100	
F			14.1			0.555
l		4.445			0.175	
L		3.3			0.130	

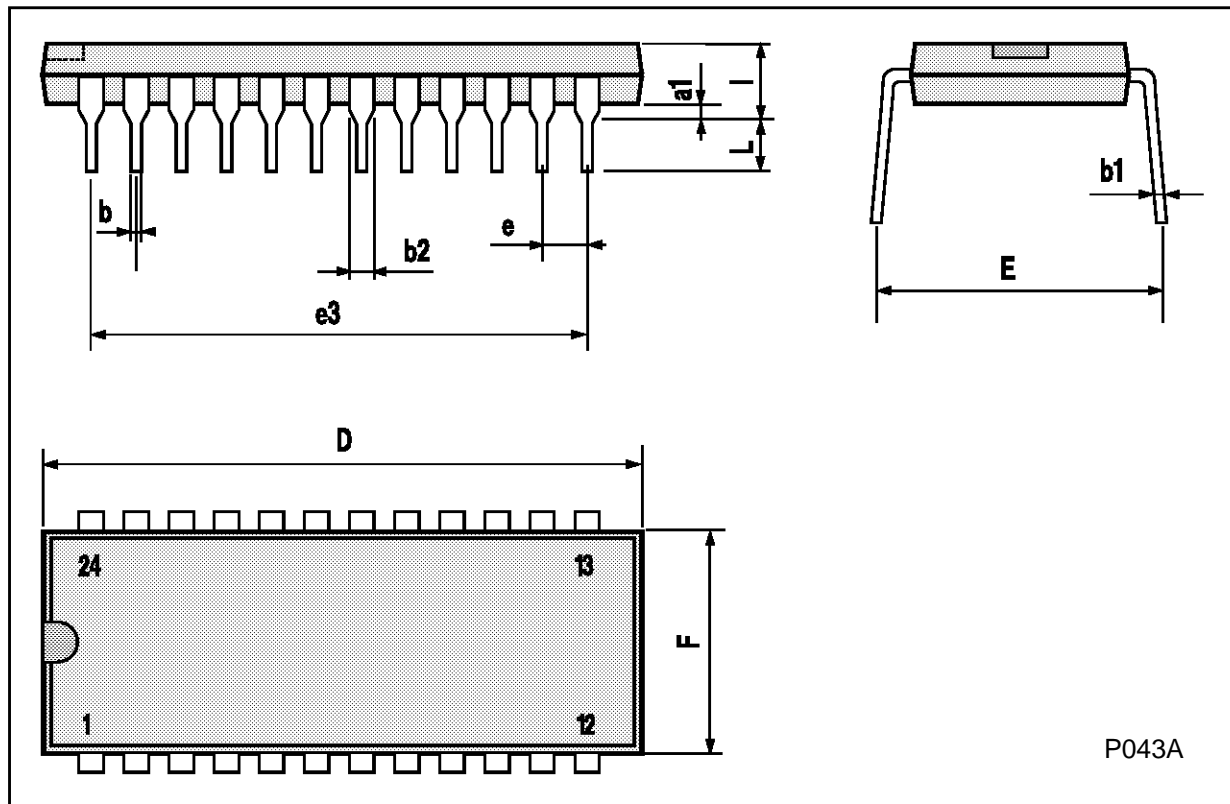

Ceramic DIP24 MECHANICAL DATA

DIM.	mm			inch		
	MIN.	TYP.	MAX.	MIN.	TYP.	MAX.
A			32.3			1.272
B	13.05		13.36	0.514		0.526
C	3.9		5.08	0.154		0.200
D	3			0.118		
E	0.5		1.78	0.020		0.070
e3		27.94			1.100	
F	2.29		2.79	0.090		0.110
G	0.4		0.55	0.016		0.022
I	1.17		1.52	0.046		0.060
L	0.22		0.31	0.009		0.012
M	1.52		2.49	0.060		0.098
N1	4° (min.), 15° (max.)					
P	15.4		15.8	0.606		0.622
Q			5.71			0.225

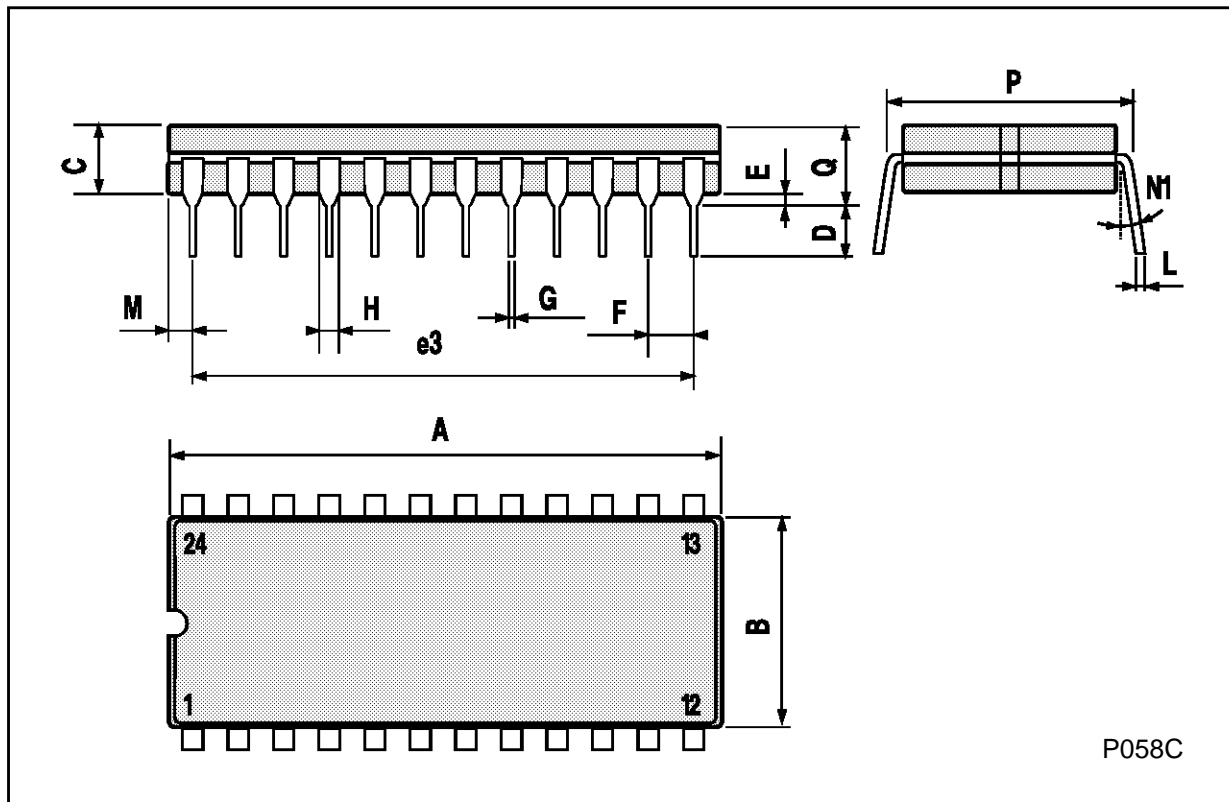

P058C

SO24 MECHANICAL DATA

DIM.	mm			inch		
	MIN.	TYP.	MAX.	MIN.	TYP.	MAX.
A			2.65			0.104
a1	0.10		0.20	0.004		0.007
a2			2.45			0.096
b	0.35		0.49	0.013		0.019
b1	0.23		0.32	0.009		0.012
C		0.50			0.020	
c1	45° (typ.)					
D	15.20		15.60	0.598		0.614
E	10.00		10.65	0.393		0.420
e		1.27			0.05	
e3		13.97			0.55	
F	7.40		7.60	0.291		0.299
L	0.50		1.27	0.19		0.050
S	8° (max.)					

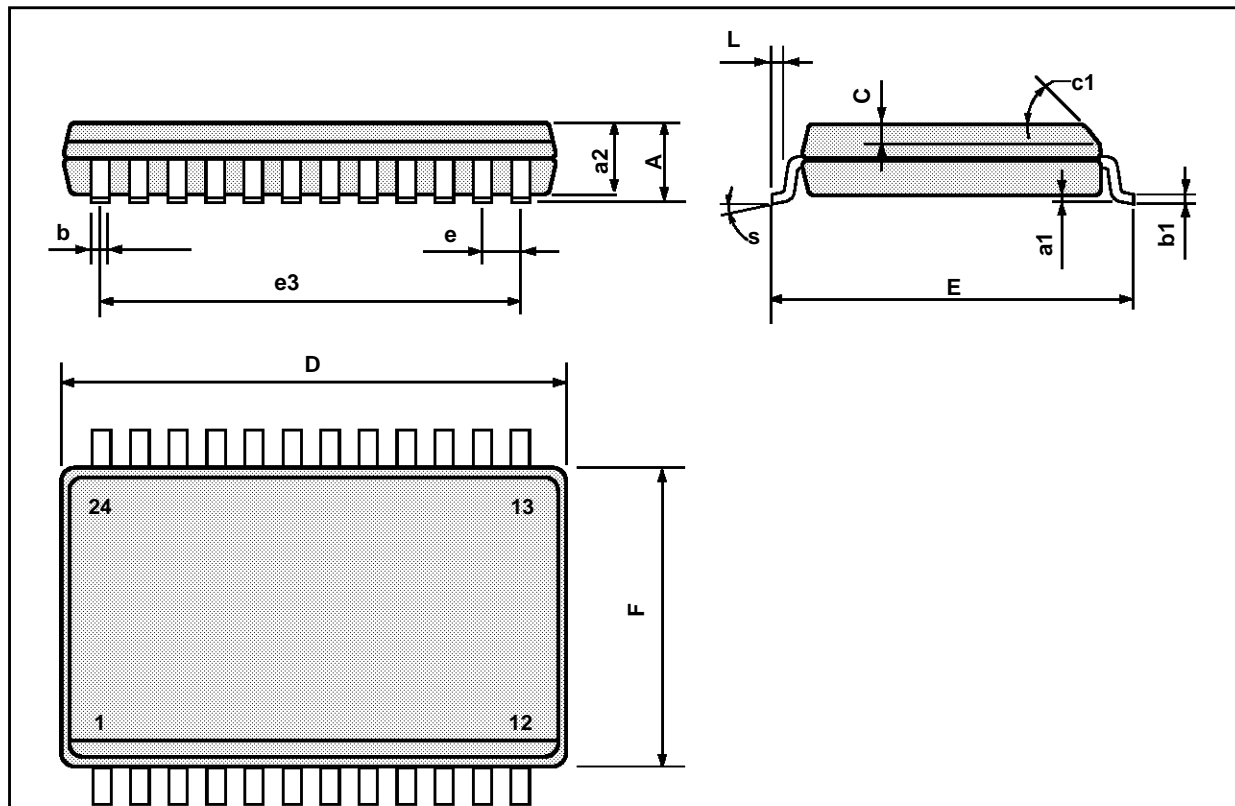

PLCC20 MECHANICAL DATA

DIM.	mm			inch		
	MIN.	TYP.	MAX.	MIN.	TYP.	MAX.
A	9.78		10.03	0.385		0.395
B	8.89		9.04	0.350		0.356
D	4.2		4.57	0.165		0.180
d1		2.54			0.100	
d2		0.56			0.022	
E	7.37		8.38	0.290		0.330
e		1.27			0.050	
e3		5.08			0.200	
F		0.38			0.015	
G			0.101			0.004
M		1.27			0.050	
M1		1.14			0.045	

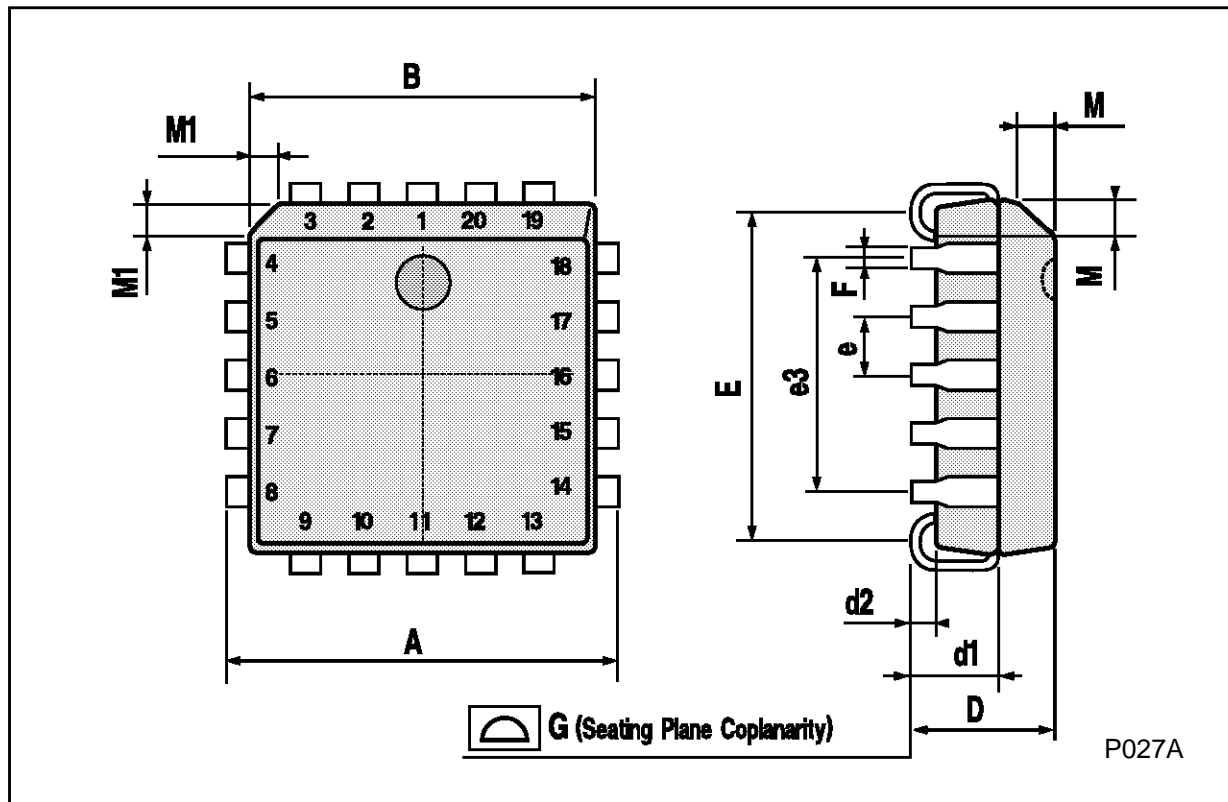

Information furnished is believed to be accurate and reliable. However, SGS-THOMSON Microelectronics assumes no responsibility for the consequences of use of such information nor for any infringement of patents or other rights of third parties which may result from its use. No license is granted by implication or otherwise under any patent or patent rights of SGS-THOMSON Microelectronics. Specifications mentioned in this publication are subject to change without notice. This publication supersedes and replaces all information previously supplied. SGS-THOMSON Microelectronics products are not authorized for use as critical components in life support devices or systems without express written approval of SGS-THOMSON Microelectronics.

© 1994 SGS-THOMSON Microelectronics - All Rights Reserved

SGS-THOMSON Microelectronics GROUP OF COMPANIES
Australia - Brazil - France - Germany - Hong Kong - Italy - Japan - Korea - Malaysia - Malta - Morocco - The Netherlands -
Singapore - Spain - Sweden - Switzerland - Taiwan - Thailand - United Kingdom - U.S.A