

**DUAL 'D' – TYPE FLIP-FLOP**

- SET-RESET CAPABILITY
- STATIC FLIP-FLOP OPERATION - RETAINS STATE INDEFINITELY WITH CLOCK LEVEL EITHER "HIGH" OR "LOW"
- MEDIUM-SPEED OPERATION - 16MHz (typ.) CLOCK TOGGLE RATE AT 10V
- QUIESCENT CURRENT SPECIFIED TO 20V FOR HCC DEVICE
- STANDARDIZED SYMMETRICAL OUTPUT CHARACTERISTICS
- 5V, 10V, AND 15V PARAMETRIC RATINGS
- INPUT CURRENT OF 100nA AT 18V AND 25°C FOR HCC DEVICE
- 100% TESTED FOR QUIESCENT CURRENT
- MEETS ALL REQUIREMENTS OF JEDEC TENTATIVE STANDARD No. 13A, "STANDARD SPECIFICATIONS FOR DESCRIPTION OF "B" SERIES CMOS DEVICES"

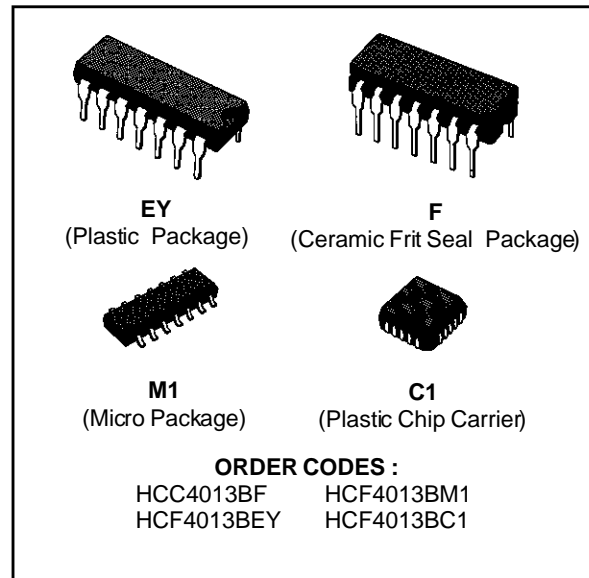

**DESCRIPTION**

The **HCC4013B** (extended temperature range) and **HCF4013B** (intermediate temperature range) are monolithic integrated circuits, available in 14-lead dual in-line plastic or ceramic package and plastic micropackage.

The **HCC/HCF4013B** consists of two identical, independent data-type flip-flops. Each flip-flop has independent data, set, reset, and clock inputs and Q and  $\bar{Q}$  outputs. These devices can be used for shift register applications, and, by connecting  $\bar{Q}$  output to the data input, for counter and toggle applications. The logic level present at the D input is transferred to the  $\bar{Q}$  output during the positive-going transition of the clock pulse. Setting or resetting is independent of the clock and is accomplished by a high level on the set or reset line, respectively.

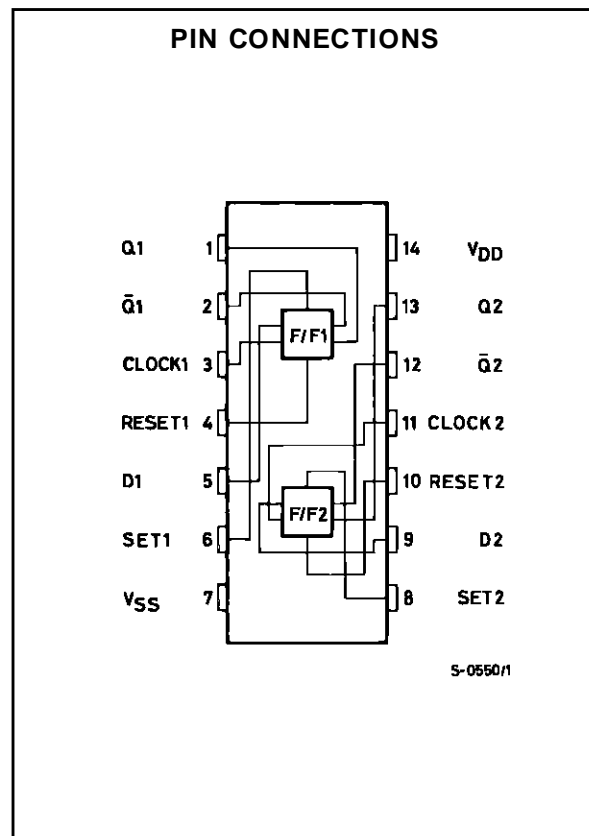

# HCC/HFC4013B

## ABSOLUTE MAXIMUM RATINGS

Symbol	Parameter	Value	Unit
$V_{DD}^*$	Supply Voltage : <b>HCC</b> Types <b>HCF</b> Types	- 0.5 to + 20	V
		- 0.5 to + 18	V
$V_i$	Input Voltage	- 0.5 to $V_{DD} + 0.5$	V
$I_i$	DC Input Current (any one input)	$\pm 10$	mA
$P_{tot}$	Total Power Dissipation (per package) Dissipation per Output Transistor for $T_{op}$ = Full Package-temperature Range	200	mW
		100	mW
$T_{op}$	Operating Temperature : <b>HCC</b> Types <b>HCF</b> Types	- 55 to + 125	$^{\circ}C$
		- 40 to + 85	$^{\circ}C$
$T_{stg}$	Storage Temperature	- 65 to + 150	$^{\circ}C$

Stresses above those listed under "Absolute Maximum Ratings" may cause permanent damage to the device. This is a stress rating only and functional operation of the device at these or any other conditions above those indicated in the operational sections of this specification is not implied. Exposure to absolute maximum rating conditions for external periods may affect device reliability.

\* All voltages are with respect to  $V_{SS}$  (GND).

## RECOMMENDED OPERATING CONDITIONS

Symbol	Parameter	Value	Unit
$V_{DD}$	Supply Voltage : <b>HCC</b> Types <b>HCF</b> Types	3 to 18	V
		3 to 15	V
$V_i$	Input Voltage	0 to $V_{DD}$	V
$T_{op}$	Operating Temperature : <b>HCC</b> Types <b>HCF</b> Types	- 55 to + 125	$^{\circ}C$
		- 40 to + 85	$^{\circ}C$

## LOGIC DIAGRAM AND TRUTH TABLE (one of two identical flip-flops)

$\Delta$  (10) RESET  
 $\Delta$  (9) DATA  
 $\Delta$  (8) SET  
 $\Delta$  (11) CL  
 PIN 14 =  $V_{DD}$   
 PIN 7 =  $V_{SS}$   
 \*ALL INPUTS ARE PROTECTED BY COS/MOS PROTECTION NETWORK

$CL^A$	D	R	S	Q	$\bar{Q}$
$\Delta$	0	0	0	0	1
$\Delta$	1	0	0	1	0
$\Delta$	X	0	0	Q	$\bar{Q}$
X	X	1	0	0	1
X	X	0	1	1	0
X	X	1	1	1	1

LOGIC 0 = LOW       $\Delta$  = LOW LEVEL  
 LOGIC 1 = HIGH    X = DON'T CARE  
 N(N) = FF1/FF2 TERMINAL ASSIGNMENT

S-2299

## STATIC ELECTRICAL CHARACTERISTICS (over recommended operating conditions)

Symbol	Parameter		Test Conditions				Value						Unit	
			V <sub>I</sub> (V)	V <sub>O</sub> (V)	I <sub>O</sub>   ( $\mu$ A)	V <sub>DD</sub> (V)	T <sub>Low</sub> *		25°C			T <sub>High</sub> *		
							Min.	Max.	Min.	Typ.	Max.	Min.		Max.
I <sub>L</sub>	Quiescent Current	HCC Types	0/5			5		1		0.02	1		30	$\mu$ A
			0/10			10		2		0.02	2		60	
			0/15			15		4		0.02	4		120	
			0/20			20		20		0.04	20		600	
		HCF Types	0/5			5		4		0.02	4		30	
			0/10			10		8		0.02	8		60	
			0/15			15		16		0.02	16		120	
V <sub>OH</sub>	Output High Voltage	0/5		< 1	5	4.95		4.95			4.95		V	
		0/10		< 1	10	9.95		9.95			9.95			
		0/15		< 1	15	14.95		14.95			14.95			
V <sub>OL</sub>	Output Low Voltage	5/0		< 1	5		0.05			0.05		0.05	V	
		10/0		< 1	10		0.05			0.05		0.05		
		15/0		< 1	15		0.05			0.05		0.05		
V <sub>IH</sub>	Input High Voltage		0.5/4.5	< 1	5	3.5		3.5			3.5		V	
			1/9	< 1	10	7		7			7			
			1.5/13.5	< 1	15	11		11			11			
V <sub>IL</sub>	Input Low Voltage		4.5/0.5	< 1	5		1.5			1.5		1.5	V	
			9/1	< 1	10		3			3		3		
			13.5/1.5	< 1	15		4			4		4		
I <sub>OH</sub>	Output Drive Current	HCC Types	0/5	2.5		5	- 2		- 1.6	- 3.2		- 1.15	mA	
			0/5	4.6		5	- 0.64		- 0.51	- 1		- 0.36		
			0/10	9.5		10	- 1.6		- 1.3	- 2.6		- 0.9		
			0/15	13.5		15	- 4.2		- 3.4	- 6.8		- 2.4		
		HCF Types	0/ 5	2.5		5	- 1.53		- 1.36	- 3.2		- 1.1		
			0/ 5	4.6		5	- 0.52		- 0.44	- 1		- 0.36		
			0/10	9.5		10	- 1.3		- 1.1	- 2.6		- 0.9		
0/15	13.5		15	- 3.6		- 3.0	- 6.8		- 2.4					
I <sub>OL</sub>	Output Sink Current	HCC Types	0/5	0.4		5	0.64		0.51	1		0.36	mA	
			0/10	0.5		10	1.6		1.3	2.6		0.9		
			0/15	1.5		15	4.2		3.4	6.8		2.4		
		HCF Types	0/5	0.4		5	0.52		0.44	1		0.36		
			0/10	0.5		10	1.3		1.1	2.6		0.9		
			0/15	1.5		15	3.6		3.0	6.8		2.4		
I <sub>IH</sub> , I <sub>IL</sub>	Input Leakage Current	HCC Types	0/18	Any Input		18		$\pm$ 0.1		$\pm$ 10 <sup>-5</sup>	$\pm$ 0.1		$\pm$ 1	$\mu$ A
		HCF Types	0/15	Any Input		15		$\pm$ 0.3		$\pm$ 10 <sup>-5</sup>	$\pm$ 0.3		$\pm$ 1	
C <sub>I</sub>	Input Capacitance		Any Input						5	7.5			pF	

\* T<sub>Low</sub>= - 55°C for HCC device : - 40°C for HCF device.\* T<sub>High</sub>= + 125°C for HCC device : + 85°C for HCF device.The Noise Margin for both "1" and "0" level is: 1V min. with V<sub>DD</sub> = 5V, 2V min. with V<sub>DD</sub> = 10V, 2.5 V min. with V<sub>DD</sub> = 15V.

## HCC/HFC4013B

**DYNAMIC ELECTRICAL CHARACTERISTICS** ( $T_{amb} = 25^{\circ}\text{C}$ ,  $C_L = 50\text{pF}$ ,  $R_L = 200\text{k}\Omega$ , typical temperature coefficient for all  $V_{DD} = 0.3\%/^{\circ}\text{C}$  values, all input rise and fall time = 20ns)

Symbol	Parameter	Test Conditions		Value			Unit
			$V_{DD}$ (V)	Min.	Typ.	Max.	
$t_{PLH}, t_{PHL}$	Propagation Delay Time (clock to Q or $\bar{Q}$ outputs)		5		150	300	ns
			10		65	130	
			15		45	90	
$t_{PLH}$	Propagation Delay Time (set to Q or reset to $\bar{Q}$ )		5		150	300	ns
			10		65	130	
			15		45	90	
$t_{PHL}$	Propagation Delay Time (set to $\bar{Q}$ or reset to Q)		5		200	400	ns
			10		85	170	
			15		60	120	
$t_{THL}, t_{TLH}$	Transition Time		5		100	200	ns
			10		50	100	
			15		40	80	
$f_{CL}^*$	Maximum Clock Input Frequency		5	3.5	7		MHz
			10	8	16		
			15	12	24		
$t_W$	Clock Pulse Width		5	140	70		ns
			10	60	30		
			15	40	20		
$t_r, t_f^{**}$	Clock Input Rise or Fall Time		5			15	$\mu\text{s}$
			10			4	
			15			1	
$t_W$	Set or Reset Pulse Width		5	180	90		ns
			10	80	40		
			15	50	25		
$t_{setup}$	Data Setup Time		5	40	20		ns
			10	20	10		
			15	15	7		

\* Input  $t_r, t_f = 5\text{ns}$ .

\*\* If more than unit is cascaded in a parallel clocked application,  $t_r$  should be made less than or equal to the sum of the fixed propagation delay time at 15pF and the transition time of the carry output driving stage for the estimated capacitive load.

Typical Output Low (sink) Current Characteristics.

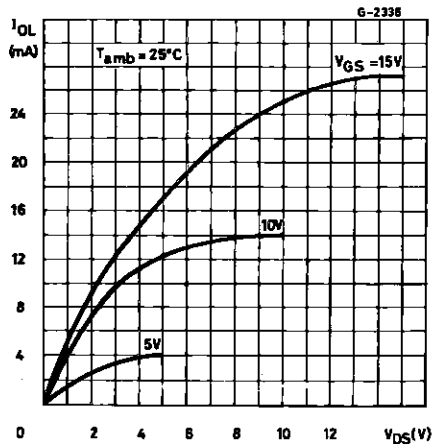

Minimum Output Low (sink) Current Characteristics.

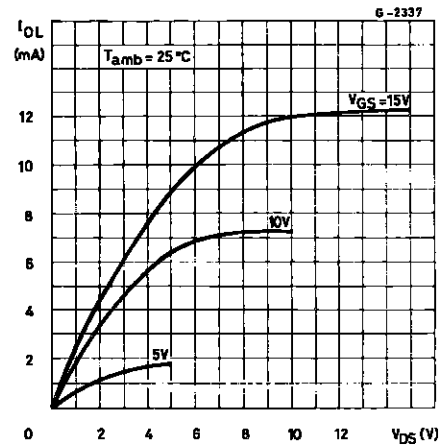

Typical Output High (source) Current Characteristics.

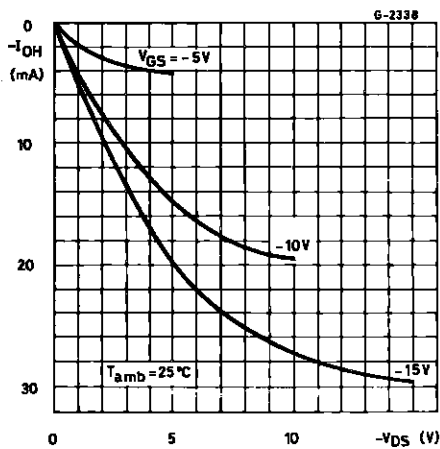

Minimum Output High (source) Current Characteristics.

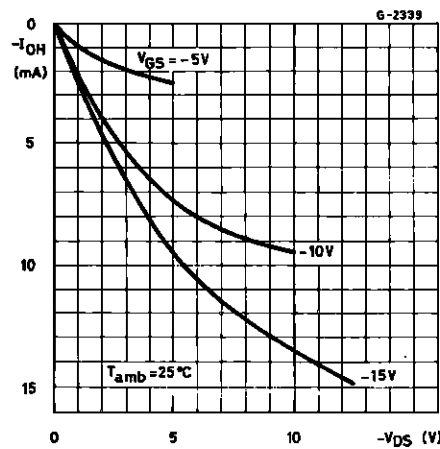

Typical Propagation Delay Time vs. Load Capacitance (CLOCK or SET to Q, CLOCK or RESET to Q).

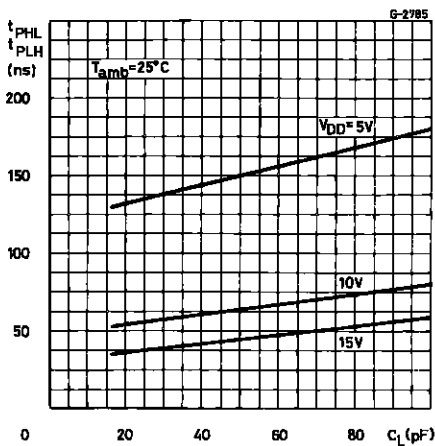

Typical Propagation Delay Time vs. Load Capacitance (SET to Q or RESET to Q).

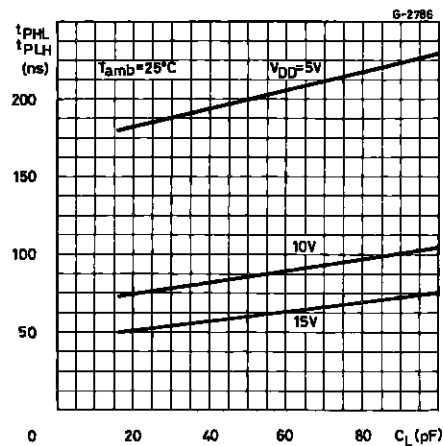

# HCC/HFC4013B

Typical Maximum Clock Frequency vs. Supply Voltage.

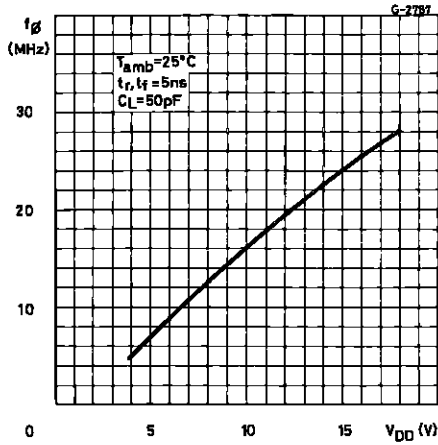

Typical Power Dissipation Device vs. Frequency.

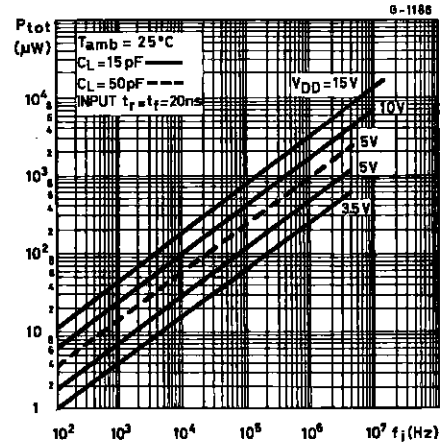

## TEST CIRCUITS

Quiescent Device Current.

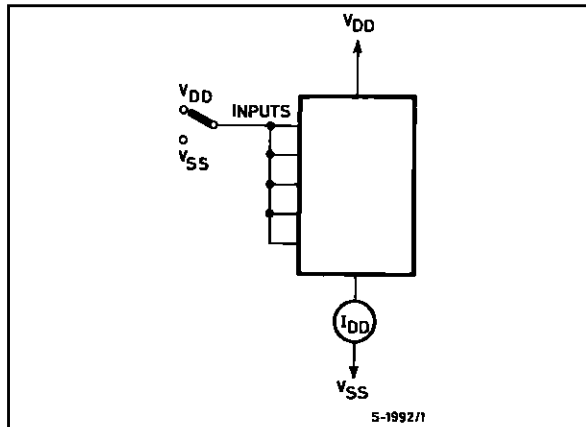

Noise Immunity.

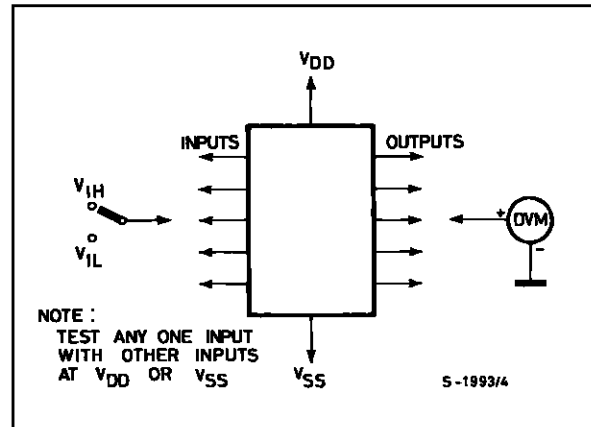

Input Leakage Current.

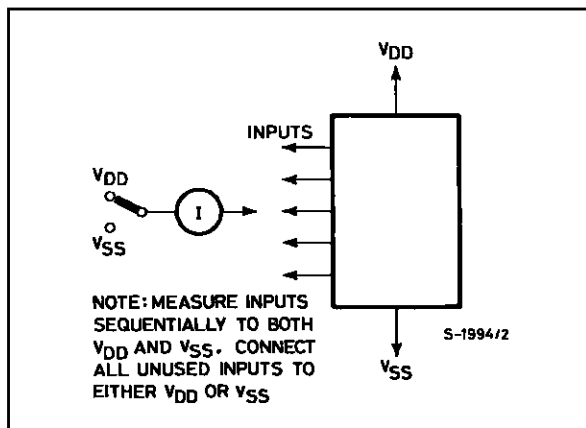

## Plastic DIP14 MECHANICAL DATA

DIM.	mm			inch		
	MIN.	TYP.	MAX.	MIN.	TYP.	MAX.
a1	0.51			0.020		
B	1.39		1.65	0.055		0.065
b		0.5			0.020	
b1		0.25			0.010	
D			20			0.787
E		8.5			0.335	
e		2.54			0.100	
e3		15.24			0.600	
F			7.1			0.280
I			5.1			0.201
L		3.3			0.130	
Z	1.27		2.54	0.050		0.100

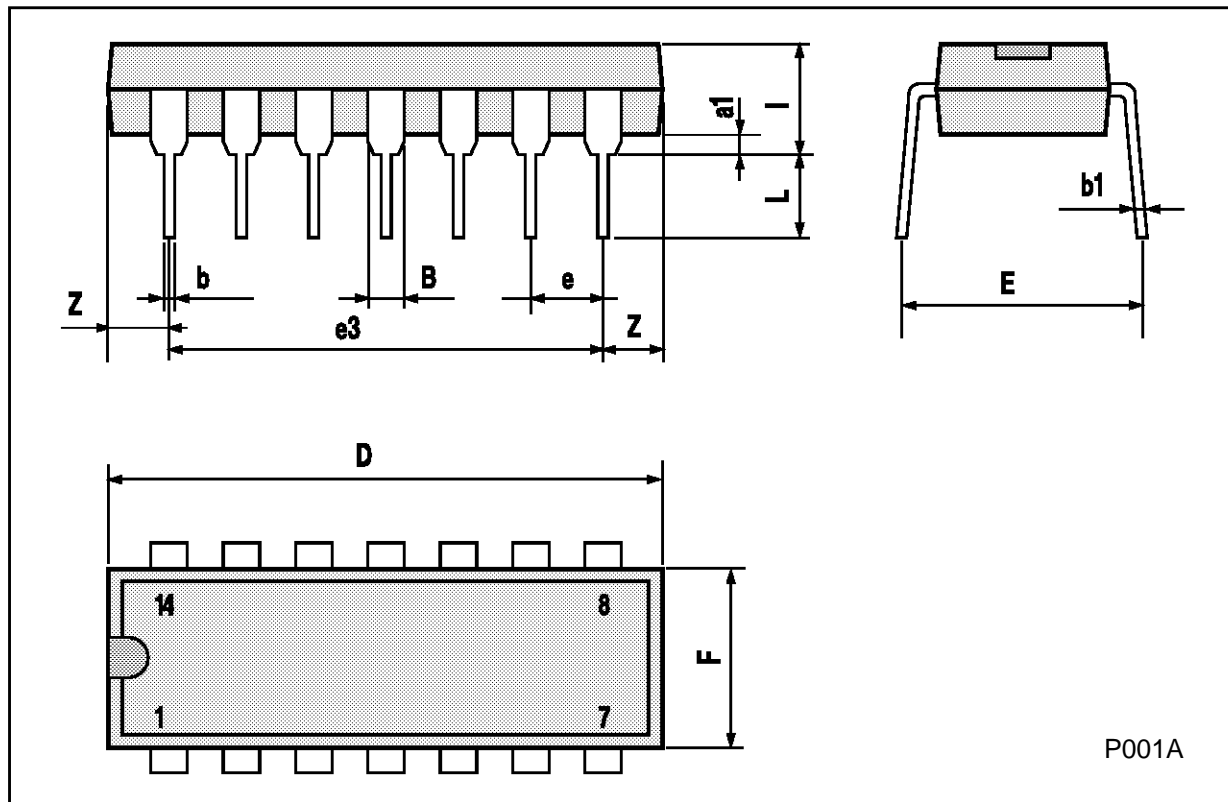

P001A

Ceramic DIP14/1 MECHANICAL DATA

DIM.	mm			inch		
	MIN.	TYP.	MAX.	MIN.	TYP.	MAX.
A			20			0.787
B			7.0			0.276
D		3.3			0.130	
E	0.38			0.015		
e3		15.24			0.600	
F	2.29		2.79	0.090		0.110
G	0.4		0.55	0.016		0.022
H	1.17		1.52	0.046		0.060
L	0.22		0.31	0.009		0.012
M	1.52		2.54	0.060		0.100
N			10.3			0.406
P	7.8		8.05	0.307		0.317
Q			5.08			0.200

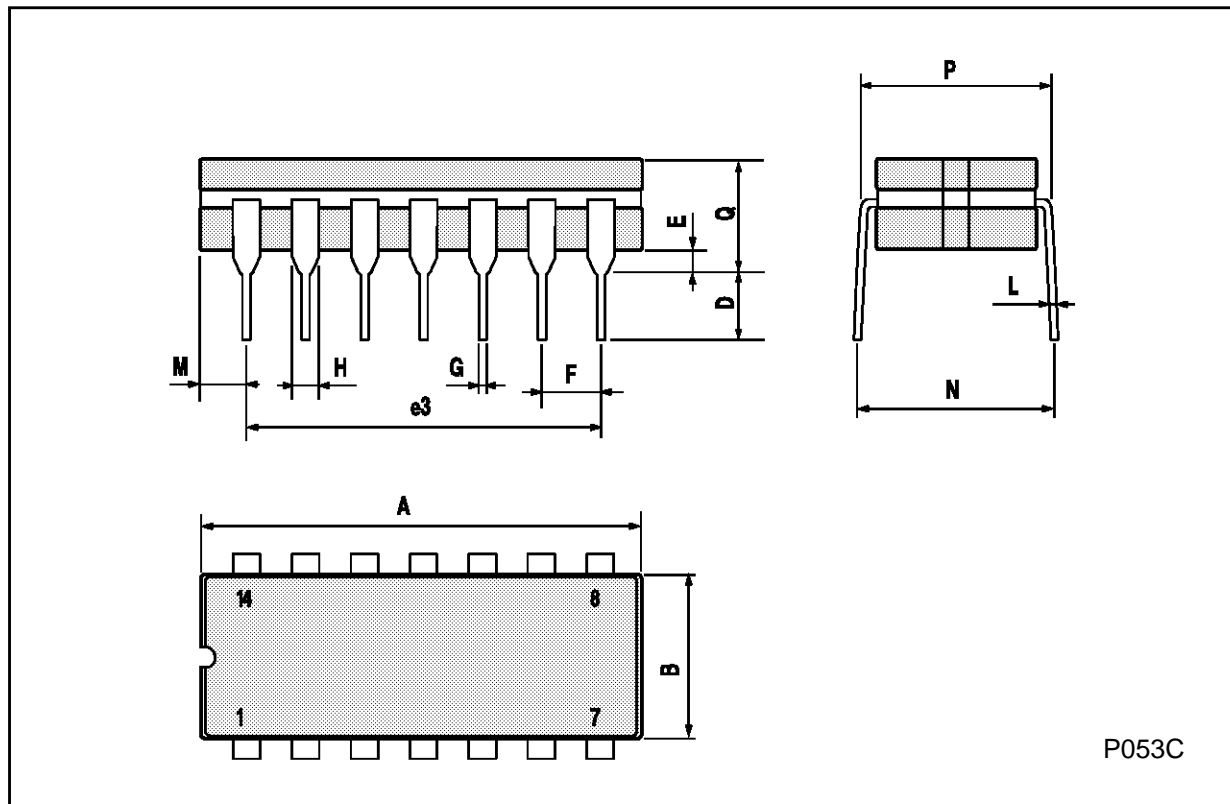

P053C

**SO14 MECHANICAL DATA**

DIM.	mm			inch		
	MIN.	TYP.	MAX.	MIN.	TYP.	MAX.
A			1.75			0.068
a1	0.1		0.2	0.003		0.007
a2			1.65			0.064
b	0.35		0.46	0.013		0.018
b1	0.19		0.25	0.007		0.010
C		0.5			0.019	
c1	45° (typ.)					
D	8.55		8.75	0.336		0.344
E	5.8		6.2	0.228		0.244
e		1.27			0.050	
e3		7.62			0.300	
F	3.8		4.0	0.149		0.157
G	4.6		5.3	0.181		0.208
L	0.5		1.27	0.019		0.050
M			0.68			0.026
S	8° (max.)					

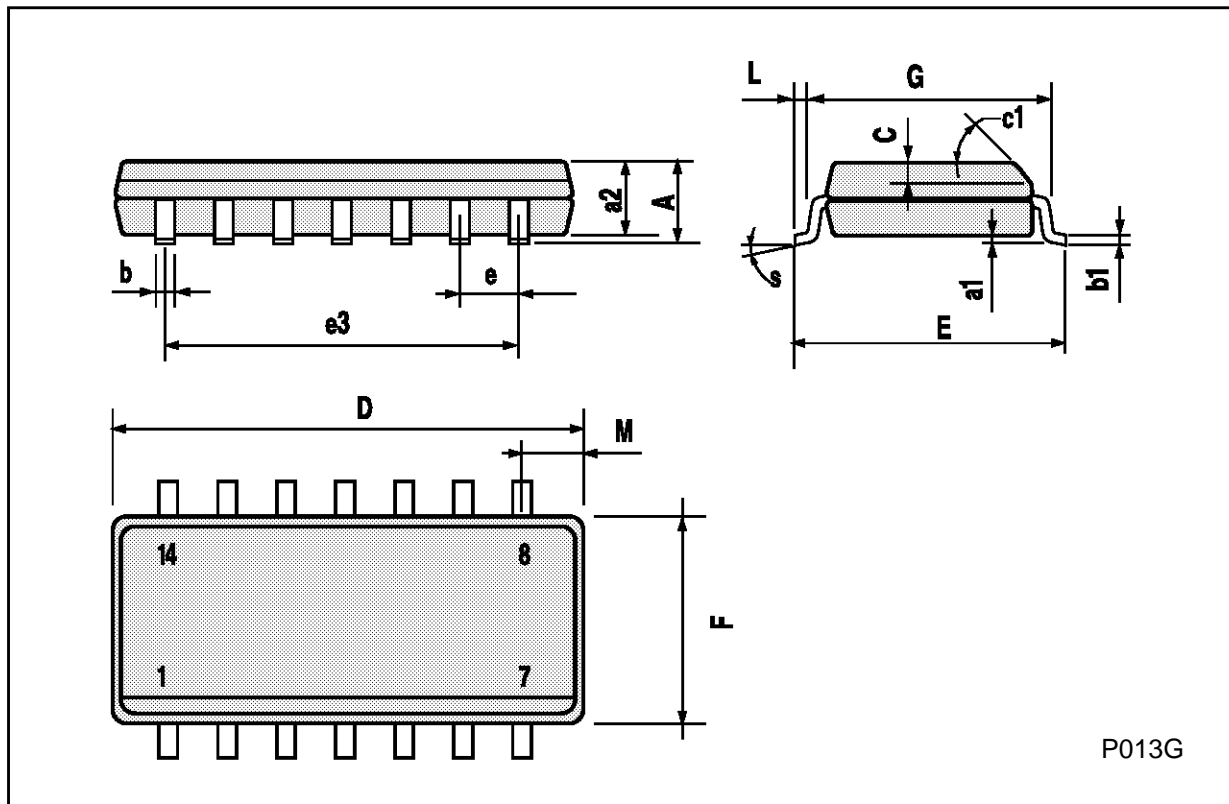

P013G

**PLCC20 MECHANICAL DATA**

DIM.	mm			inch		
	MIN.	TYP.	MAX.	MIN.	TYP.	MAX.
A	9.78		10.03	0.385		0.395
B	8.89		9.04	0.350		0.356
D	4.2		4.57	0.165		0.180
d1		2.54			0.100	
d2		0.56			0.022	
E	7.37		8.38	0.290		0.330
e		1.27			0.050	
e3		5.08			0.200	
F		0.38			0.015	
G			0.101			0.004
M		1.27			0.050	
M1		1.14			0.045	



Information furnished is believed to be accurate and reliable. However, SGS-THOMSON Microelectronics assumes no responsibility for the consequences of use of such information nor for any infringement of patents or other rights of third parties which may result from its use. No license is granted by implication or otherwise under any patent or patent rights of SGS-THOMSON Microelectronics. Specifications mentioned in this publication are subject to change without notice. This publication supersedes and replaces all information previously supplied. SGS-THOMSON Microelectronics products are not authorized for use as critical components in life support devices or systems without express written approval of SGS-THOMSON Microelectronics.

© 1994 SGS-THOMSON Microelectronics - All Rights Reserved

SGS-THOMSON Microelectronics GROUP OF COMPANIES

Australia - Brazil - France - Germany - Hong Kong - Italy - Japan - Korea - Malaysia - Malta - Morocco - The Netherlands -  
Singapore - Spain - Sweden - Switzerland - Taiwan - Thailand - United Kingdom - U.S.A