

8-STAGE STATIC BIDIRECTIONAL PARALLEL/SERIAL INPUT/OUTPUT BUS REGISTER

- BIDIRECTIONAL PARALLEL DATA INPUT
- PARALLEL OR SERIAL INPUTS/PARALLEL OUTPUTS
- ASYNCHRONOUS OR SYNCHRONOUS PARALLEL DATA LOADING
- PARALLEL DATA-INPUT ENABLE ON "A" DATA LINES (3-state output)
- DATA RECIRCULATION FOR REGISTER EXPANSION
- MULTIPACKAGE REGISTER EXPANSION
- FULLY STATIC OPERATIONAL DC-TO-5MHz (typ.) AT $V_{DD} = 10V$
- QUIESCENT CURRENT SPECIFIED TO 20V FOR HCC DEVICE
- 5V, 10V, AND 15V PARAMETRIC RATINGS
- INPUT CURRENT OF 100nA AT 18V AND 25°C FOR HCC DEVICE
- 100% TESTED FOR QUIESCENT CURRENT
- MEETS ALL REQUIREMENTS OF JEDEC TENTATIVE STANDARD N° 13A, "STANDARD SPECIFICATIONS FOR DESCRIPTION OF "B" SERIES CMOS DEVICES"

DESCRIPTION

The **HCC4034B** (extended temperature range) and **HCF4034B** (intermediate temperature range) are monolithic integrated circuits, available in 24-lead dual in-line plastic or ceramic package and plastic micro package. The **HCC/HCF4034B** is a static eight-stage parallel-or serial-input parallel-output register. It can be used to : 1) bidirectionally transfer parallel information between two buses ; 2) convert serial data to parallel form and direct the parallel data to either of two buses ; 3) store (recirculate) parallel data, or 4) accept parallel data from either of two buses and convert that data to serial form. Inputs that control the operations include a single-phase CLOCK (CL), A DATA ENABLE (AE), ASYNCHRONOUS/SYNCHRONOUS (A/S), A-BUS-TO-B-BUS/B-BUS-TO-A-BUS (A/B), and PARALLEL/SERIAL (P/S). Data inputs include 16 bidirectional parallel data lines of which the eight A data lines are inputs (3-state outputs) and the B data lines are outputs (inputs) depending on the signal level on the A/B input. In addition, an input for SERIAL DATA is also provided. All register stages are D-type master-slave flip-flops with separate master and slave clock

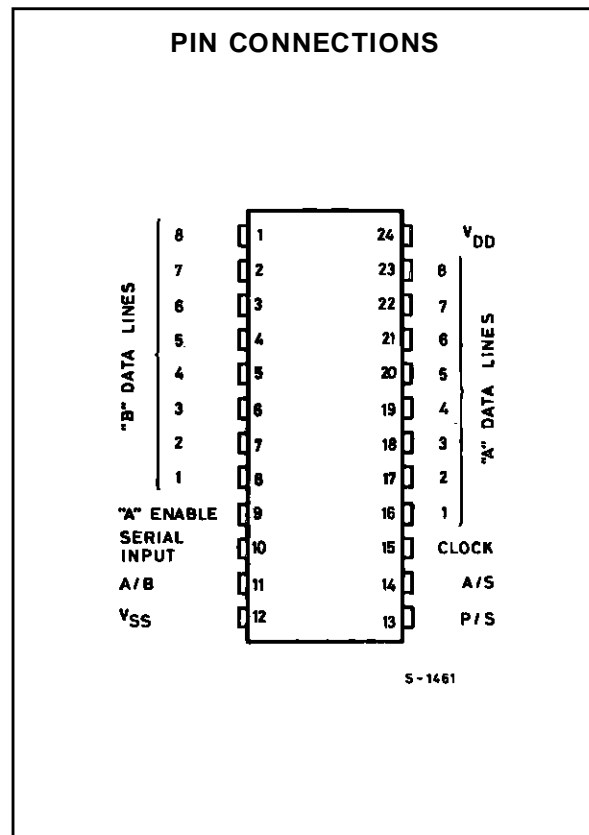
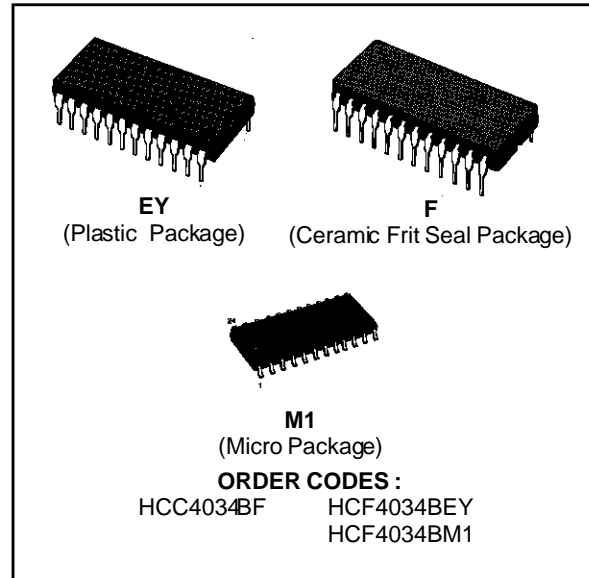

HCC/HCF4034B

inputs generated internally to allow synchronous or asynchronous data transfer from master to slave. Isolation from external noise and the effects of loading is provided by output buffering.

PARALLEL OPERATION – A high P/S input signal allows data transfer into the register via the parallel data lines synchronously with the positive transition of the clock provided the A/S input is low. If the A/S input is high the transfer is independent of the clock. The direction of data flow is controlled by the A/B input. When this signal is high the A data lines are inputs (and B data lines are outputs) ; a low A/B signal reverses the direction of data flow. The AE-input is an additional feature which allows many registers to feed data to a common bus. The A DATA lines are

enabled only when this signal is high. Data storage through recirculation of data in each register stage is accomplished by making the A/B signal high and the AE signal low.

SERIAL OPERATION – A low P/S signal allows serial data to transfer into the register synchronously with the positive transition of the clock. The A/S input is internally disabled when the register is in the serial mode (asynchronous serial operation is not allowed). The serial data appears as output data on either the B lines (when A/B is high) or the A lines (when A/B is low and the AE signal is high). Register expansion can be accomplished by simply cascading **HCC/HCF4034B** packages.

FUNCTIONAL DIAGRAM

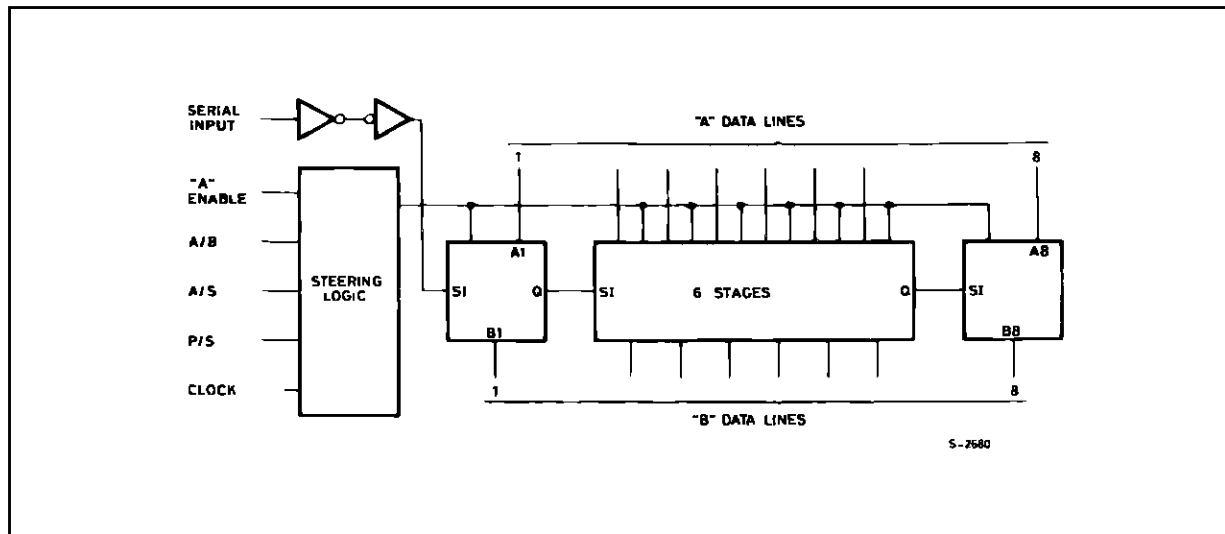

ABSOLUTE MAXIMUM RATINGS

Symbol	Parameter	Value	Unit
V_{DD}^*	Supply Voltage : HCC Types HCF Types	- 0.5 to + 20 - 0.5 to + 18	V
V_i	Input Voltage	- 0.5 to $V_{DD} + 0.5$	V
I_i	DC Input Current (any one input)	± 10	mA
P_{tot}	Total Power Dissipation (per package) Dissipation per Output Transistor for T_{op} = Full Package-temperature Range	200 100	mW
T_{op}	Operating Temperature : HCC Types HCF Types	- 55 to + 125 - 40 to + 85	$^{\circ}C$
T_{stg}	Storage Temperature	- 65 to + 150	$^{\circ}C$

Stresses above those listed under "Absolute Maximum Ratings" may cause permanent damage to the device. This is a stress rating only and functional operation of the device at these or any other conditions above those indicated in the operational sections of this specification is not implied. Exposure to absolute maximum rating conditions for external periods may affect device reliability.

RECOMMENDED OPERATING CONDITIONS

Symbol	Parameter	Value	Unit
V_{DD}	Supply Voltage : HCC Types	3 to 18	V
	HCF Types	3 to 15	V
V_I	Input Voltage	0 to V_{DD}	V
T_{op}	Operating Temperature : HCC Types	- 55 to + 125	°C
	HCF Types	- 40 to + 85	°C

LOGIC DIAGRAMS

STEERING LOGIC

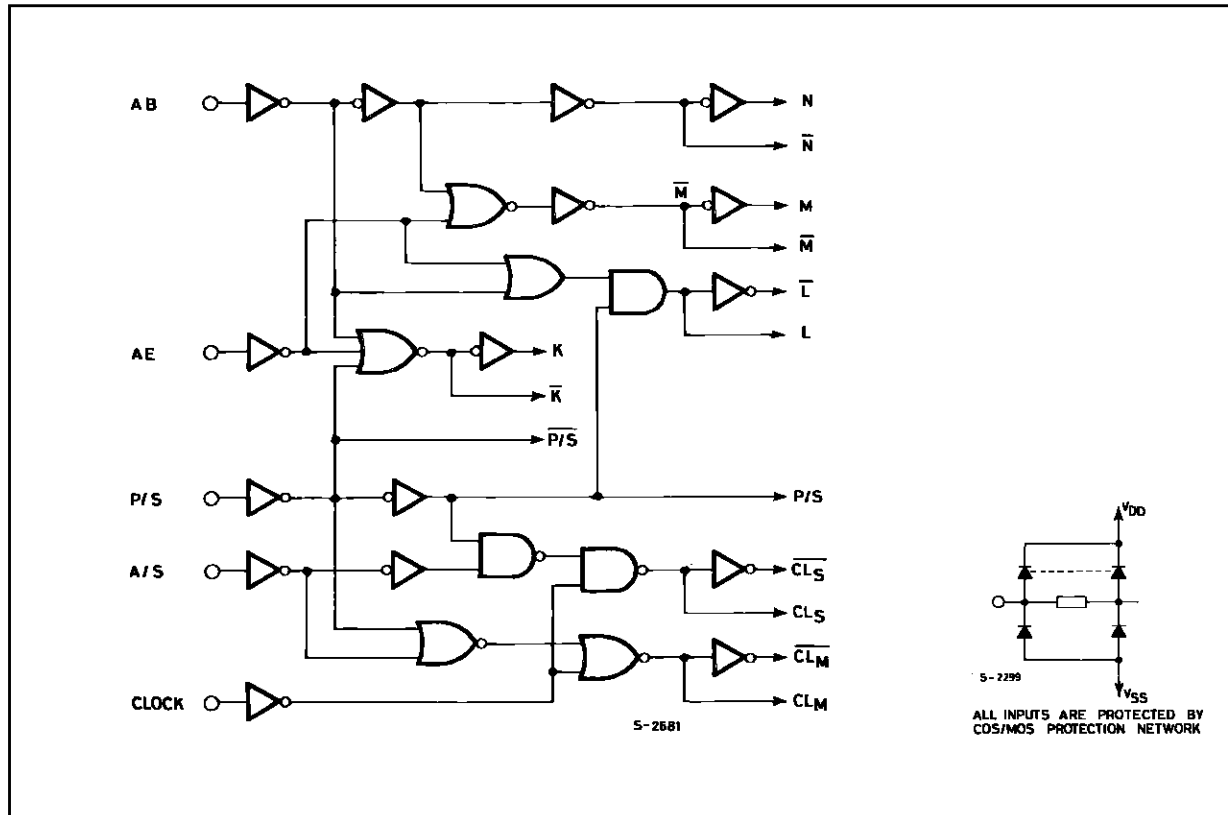

LOGIC DIAGRAM AND TRUTH TABLE

REGISTER STAGE (1 of 8 stages)

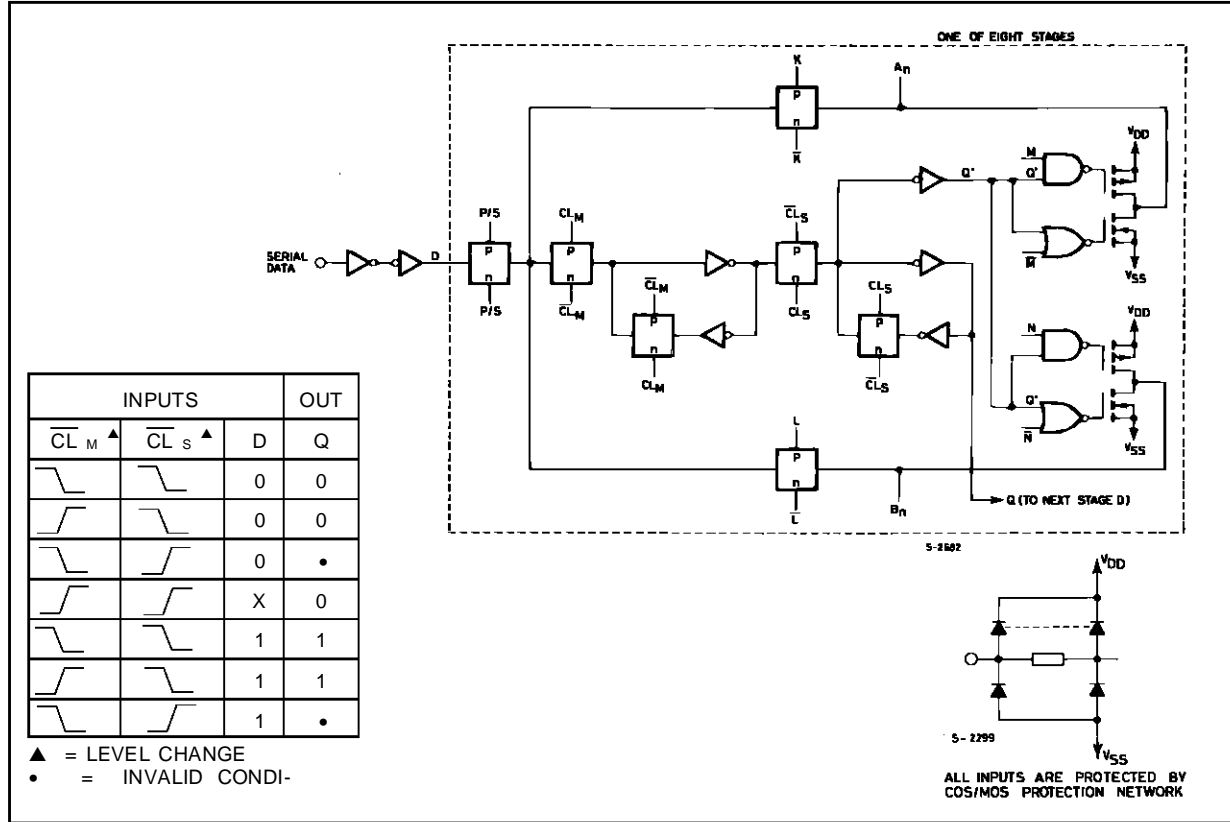

FOR REGISTER INPUT-LEVELS AND RESULTING REGISTER OPERATION

"A" Enable	P/S	A/B	A/S	Operation*
0	0	0	X	Serial Mode ; Synch. Serial Data Input, "A" Parallel Data Outputs Disabled
0	0	1	X	Serial Mode ; Synch. Serial Data Input, "B" Parallel Data Output
0	1	0	0	Parallel Mode ; "B" Synch. Parallel Data Inputs, "A" Parallel Data Outputs Disabled
0	1	0	1	Parallel Mode ; "B" Asynch. Parallel Data Inputs, "A" Parallel Data Outputs Disabled
0	1	1	0	Parallel Mode ; "A" Parallel Data Inputs Disabled, "B" Parallel Data Outputs, Synch. Data Recirculation
0	1	1	1	Parallel Mode ; "A" Parallel Data Inputs Disabled, "B" Parallel Data Outputs, Asynch. Data Recirculation
1	0	0	X	Serial Mode ; Synch. Serial Data Input, "A" Parallel Data Output
1	0	1	X	Serial Mode ; Synch. Serial Data Input, "B" Parallel Data Output
1	1	0	0	Parallel Mode ; "B" Synch. Parallel Data Input, "A" Parallel Data Output
1	1	0	1	Parallel Mode ; "B" Asynch. Parallel Data Input, "A" Parallel Data Output
1	1	1	0	Parallel Mode ; "A" Synch. Parallel Data Input, "B" Parallel Data Output
1	1	1	1	Parallel Mode ; "A" Asynch. Parallel Data Input, "B" Parallel Data Output

* Outputs change at positive transition of clock in the serial mode and when the A/S control inputs is "low" in the parallel mode.

TIMING DIAGRAM

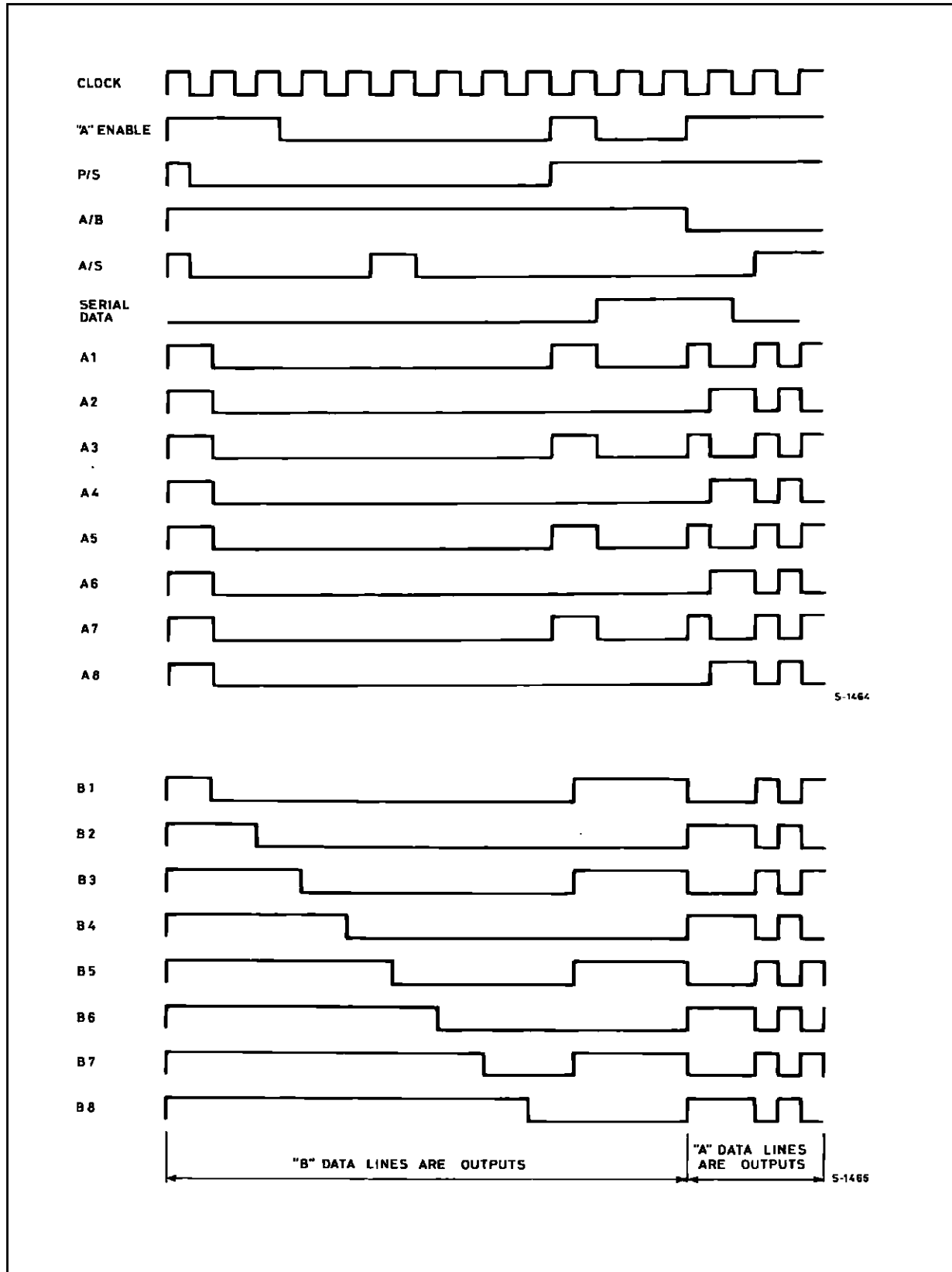

HCC/HCF4034B

STATIC ELECTRICAL CHARACTERISTICS (over recommended operating conditions)

Symbol	Parameter		Test Conditions				Values						Unit	
			V _I (V)	V _O (V)	I _O (μ A)	V _{DD} (V)	T _{Low} *		25°C			T _{High} *		
							Min.	Max.	Min.	Typ.	Max.	Min.		Max.
I _L	Quiescent Current	HCC Types	0/ 5			5		5		0.04	5		150	
			0/10			10		10		0.04	10		300	
			0/15			15		20		0.04	20		600	
			0/20			20		100		0.08	100		3000	
		HCF Types	0/ 5			5		20		0.04	20		150	
			0/10			10		40		0.04	40		300	
			0/15			15		80		0.04	80		600	
V _{OH}	Output High Voltage	0/ 5		< 1	5	4.95		4.95			4.95			
		0/10		< 1	10	9.95		9.95			9.95			
		0/15		< 1	15	14.95		14.95			14.95			
V _{OL}	Output Low Voltage	5/0		< 1	5		0.05			0.05		0.05		
		10/0		< 1	10		0.05			0.05		0.05		
		15/0		< 1	15		0.05			0.05		0.05		
V _{IH}	Input High Voltage		0.5/4.5	< 1	5	3.5		3.5			3.5			
			1/9	< 1	10	7		7			7			
			1.5/13.5	< 1	15	11		11			11			
V _{IL}	Input Low Voltage		4.5/0.5	< 1	5		1.5			1.5		1.5		
			9/1	< 1	10		3			3		3		
			13.5/1.5	< 1	15		4			4		4		
I _{OH}	Output Drive Current	HCC Types	0/ 5	2.5		5	- 2		- 1.6	- 3.2		- 1.15		
			0/ 5	4.6		5	- 0.64		- 0.51	- 1		- 0.36		
			0/10	9.5		10	- 1.6		- 1.3	- 2.6		- 0.9		
			0/15	13.5		15	- 4.2		- 3.4	- 6.8		- 2.4		
		HCF Types	0/ 5	2.5		5	- 1.53		- 1.36	- 3.2		- 1.1		
			0/ 5	4.6		5	- 0.52		- 0.44	- 1		- 0.36		
			0/10	9.5		10	- 1.3		- 1.1	- 2.6		- 0.9		
	0/15	13.5		15	- 3.6		- 3.0	- 6.8		- 2.4				
I _{OL}	Output Sink Current	HCC Types	0/ 5	0.4		5	0.64		0.51	1		0.36		
			0/10	0.5		10	1.6		1.3	2.6		0.9		
			0/15	1.5		15	4.2		3.4	6.8		2.4		
		HCF Types	0/ 5	0.4		5	0.52		0.44	1		0.36		
			0/10	0.5		10	1.3		1.1	2.6		0.9		
			0/15	1.5		15	3.6		3.0	6.8		2.4		
I _{IH} , I _{IL}	Input Leakage Current	HCC Types	0/18	Any Input		18		± 0.1		$\pm 10^{-5}$	± 0.1		± 1	
		HCF Types	0/15	Any Input		15		± 0.3		$\pm 10^{-5}$	± 0.3		± 1	
I _{OH}	3-State Output Leakage Current	HCC Types	0/18	0/18		18		± 0.4		$\pm 10^{-4}$	± 0.4		± 12	
		HCF Types	0/15	0/15		15		± 1.0		$\pm 10^{-4}$	± 1.0		± 7.5	
C _I	Input Capacitance		Any Input						5	7.5		pF		

* T_{Low} = - 55°C for HCC device ; - 40°C for HCF device.

* T_{High} = + 125°C for HCC device ; + 85°C for HCF device.

The Noise Margin for both "1" and "0" level is : 1V min. with V_{DD} = 5V, 2V min. with V_{DD} = 10V, 2.5V min. with V_{DD} = 15V.

DYNAMIC ELECTRICAL CHARACTERISTICS ($T_{amb} = 25^{\circ}\text{C}$, $C_L = 50\text{pF}$, $R_L = 200\text{k}\Omega$, typical temperature coefficient for all V_{DD} values is $0.3\%/^{\circ}\text{C}$, all input rise and fall times = 20ns)

Symbol	Parameter	Test Conditions		Value			Unit
			V_{DD} (V)	Min.	Typ.	Max.	
t_{PHL} , t_{PLH}	Propagation Delay Time : A (B) Parallel Data in to B (A) Parallel Data Out		5		350	700	ns
			10		120	240	
			15		85	170	
t_{PLZ} , t_{PHZ} t_{PZL} , t_{PZH}	3-state Propagation Delay Time A/B or AE to "A" OUT		5		200	400	ns
			10		80	160	
			15		60	120	
t_{THL} , t_{TLH}	Transition Time		5		100	200	ns
			10		50	100	
			15		40	80	
t_{setup}	Data Setup Time Serial Data to Clock		5		80	160	ns
			10		30	60	
			15		20	40	
	Parallel Data to Clock		5		25	50	ns
			10		15	30	
			15		10	20	
t_w	High-level Pulse Width, AE, P/S, A/S		5		175	350	ns
			10		70	140	
			15		40	80	
f_{CL}	Maximum Clock Frequency		5	2	4		MHz
			10	5	10		
			15	7	14		
t_w	Clock Pulse Width		5		125	250	ns
			10		50	100	
			15		35	70	
t_r , t_f^*	Clock Input Rise or Fall Time		5,10,15			15	μs

* If more than one unit is cascaded, t_r should be made less than or equal to the sum of the transition time and the fixed propagation delay of the output of the driving stage for the estimated capacitive load.

HCC/HCF4034B

Typical Output Low (sink) Current Characteristics.

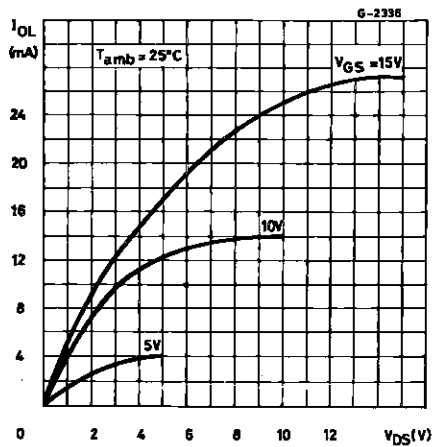

Minimum Output Low (sink) Current Characteristics.

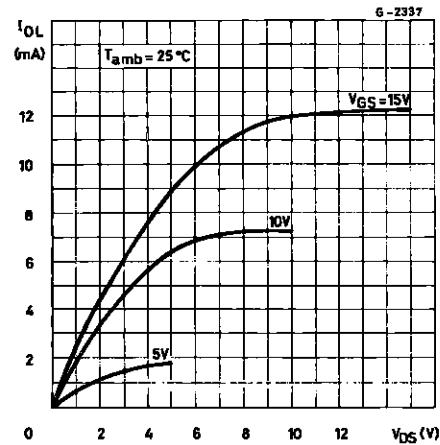

Typical Output High (source) Current Characteristics.

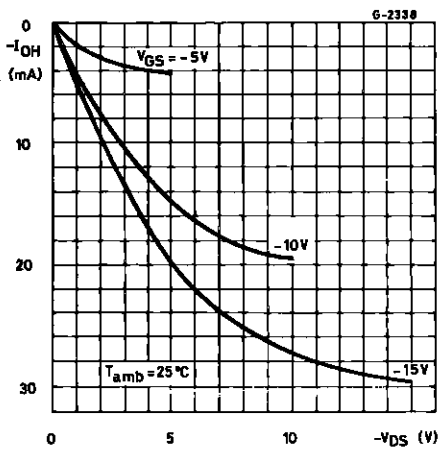

Minimum Output High (source) Current Characteristics.

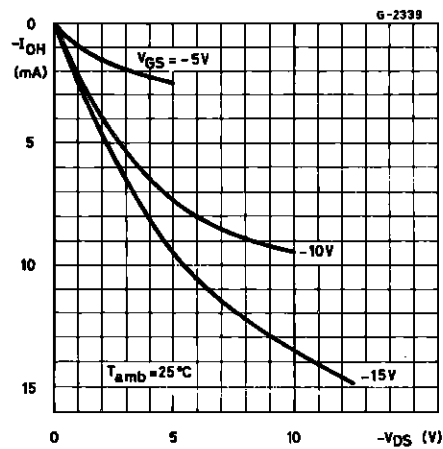

TYPICAL APPLICATIONS

16-BIT PARALLEL IN/PARALLEL OUT PARALLEL IN/SERIAL OUT, SERIAL IN/PARALLEL OUT, SERIAL IN/SERIAL OUT REGISTER.

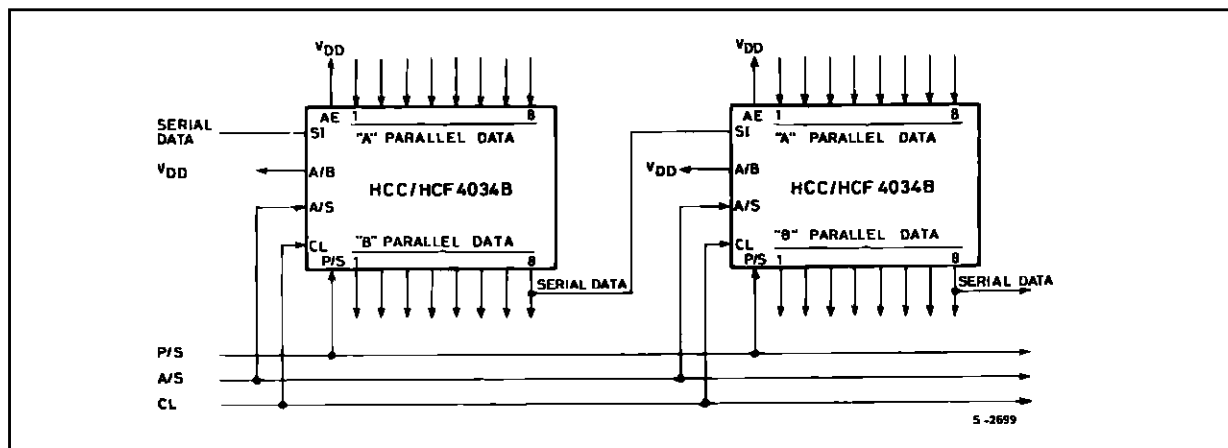

TYPICAL APPLICATIONS (continued)

16-BIT SERIAL IN/GATED PARALLEL OUT REGISTER

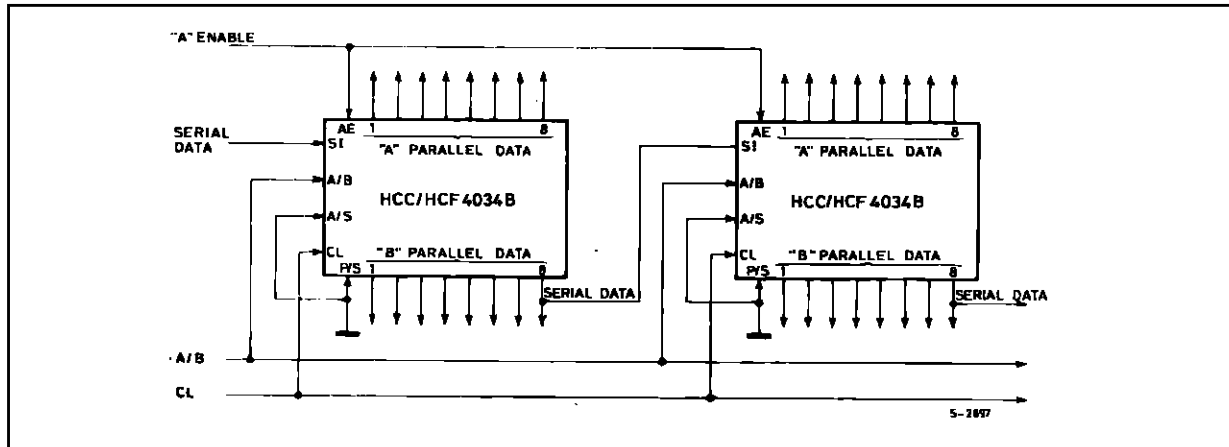

FREQUENCY AND PHASE COMPARATOR.

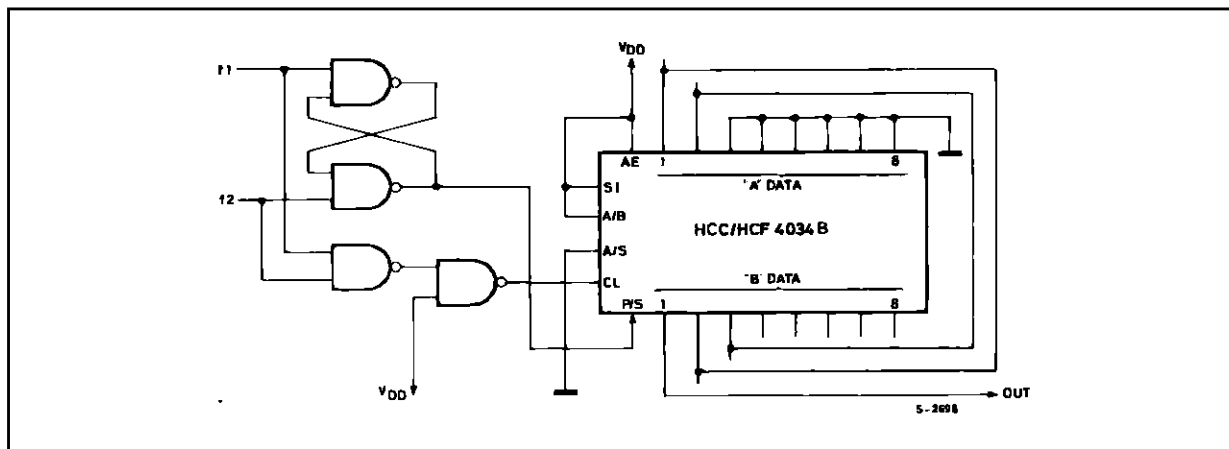

TIMING DIAGRAM

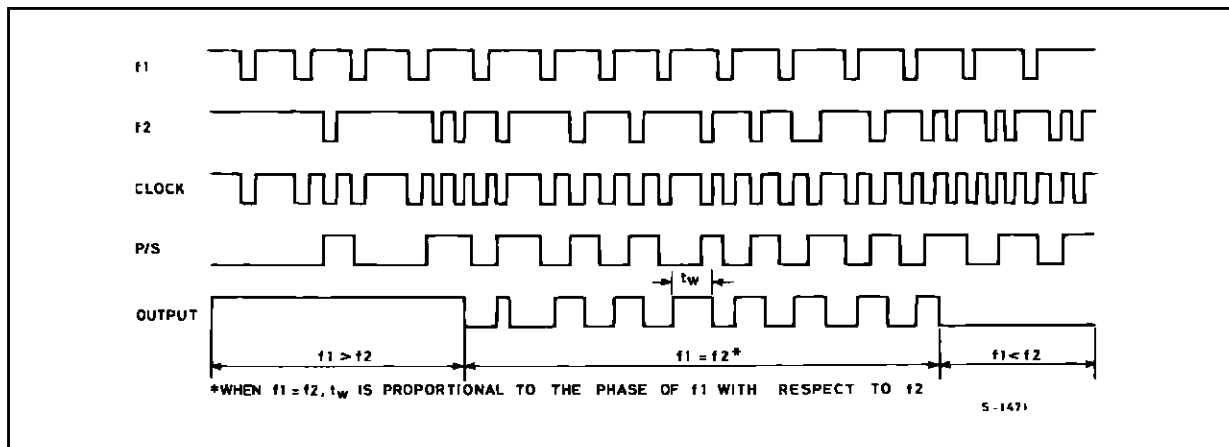

TYPICAL APPLICATIONS (continued)

SHIFT RIGHT/SHIFT LEFT WITH PARALLEL INPUTS

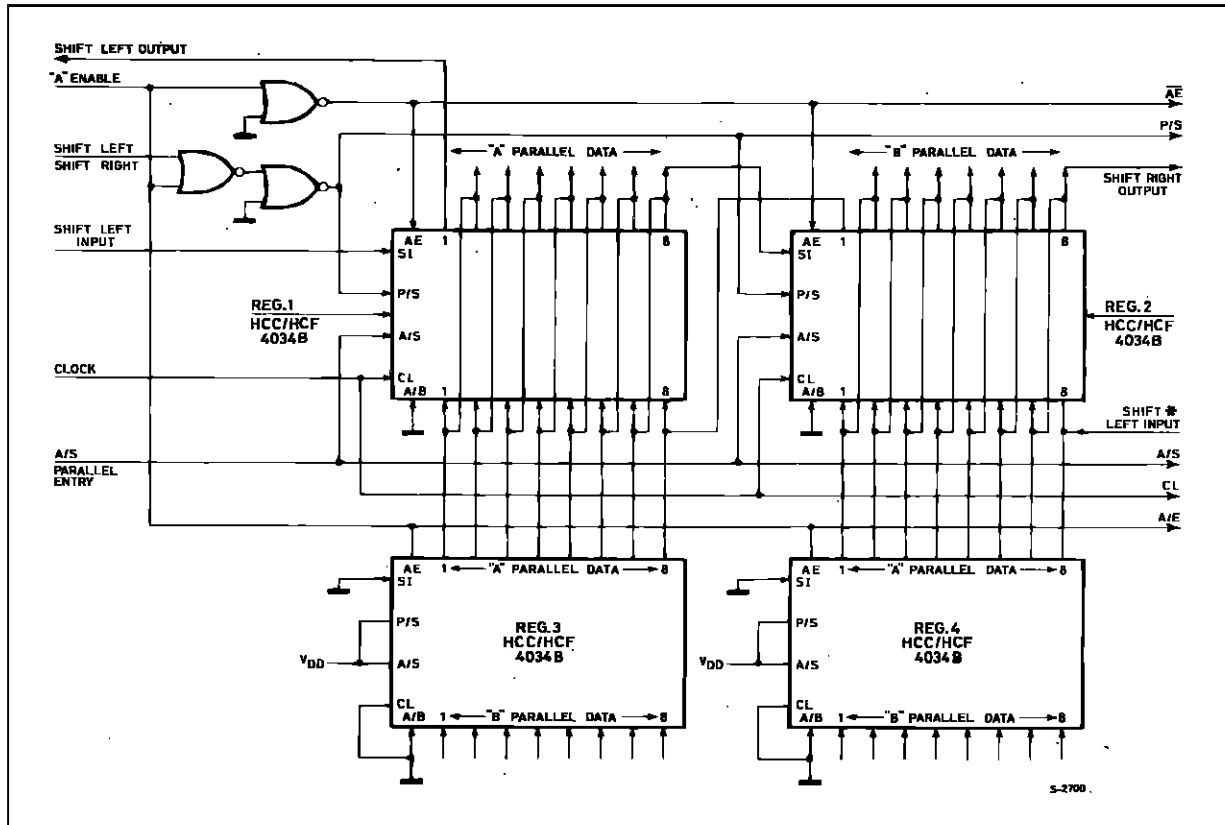

A "High" ("Low") on the Shift Left/Shift Right input allows serial data on the Shift Left Input (Shift Right Input) to enter the register on the positive transition of the clock signal. A "high" on the "A" Enable Input disables the "A" parallel data lines on Reg. 1 and 2 and enables the "A" data lines on registers 3 and 4 and allows parallel data into registers 1 and 2. Other

logic schemes may be used in place of registers 3 and 4 for parallel loading. When parallel inputs are not used Reg. 3 and 4 and associated logic are not required.

* Shift Left input must be disabled during parallel entry.

N-STAGE REGISTER WITH FIXED SERIAL OUTPUT LINE

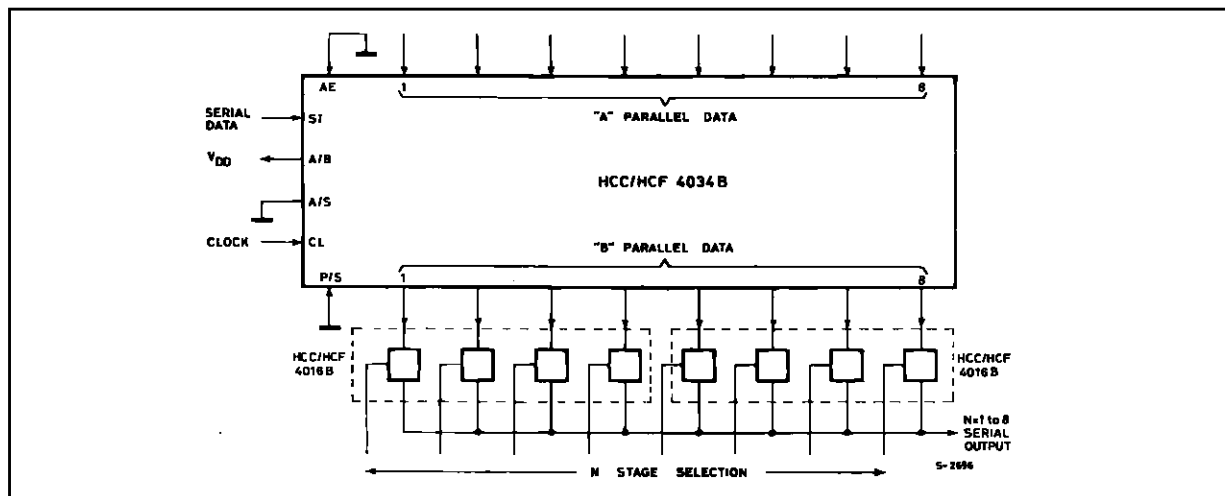

TYPICAL APPLICATIONS (continued)

SAMPLE AND HOLD REGISTER-SERIAL/PARALLEL IN-PARALLEL OUT

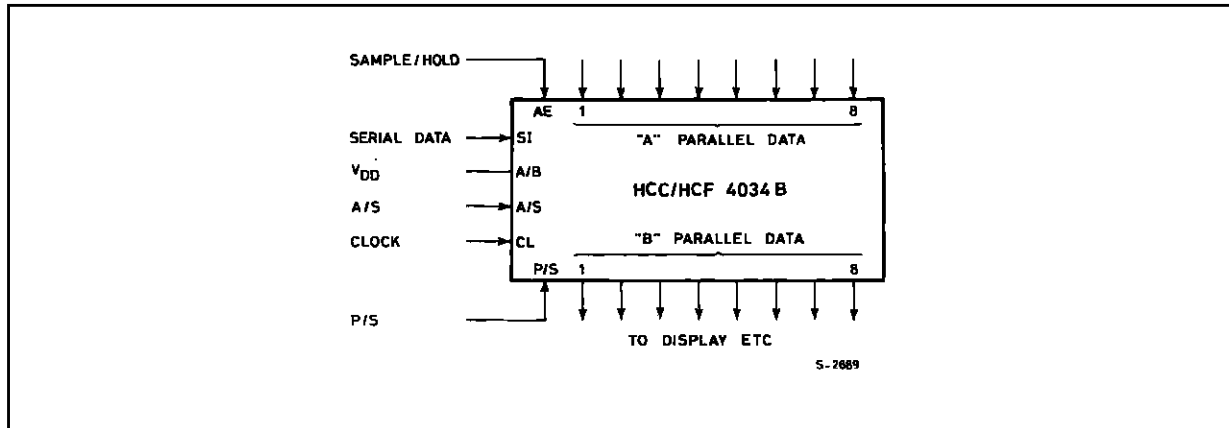

SINGLE-AND DOUBLE-BUS SYSTEMS

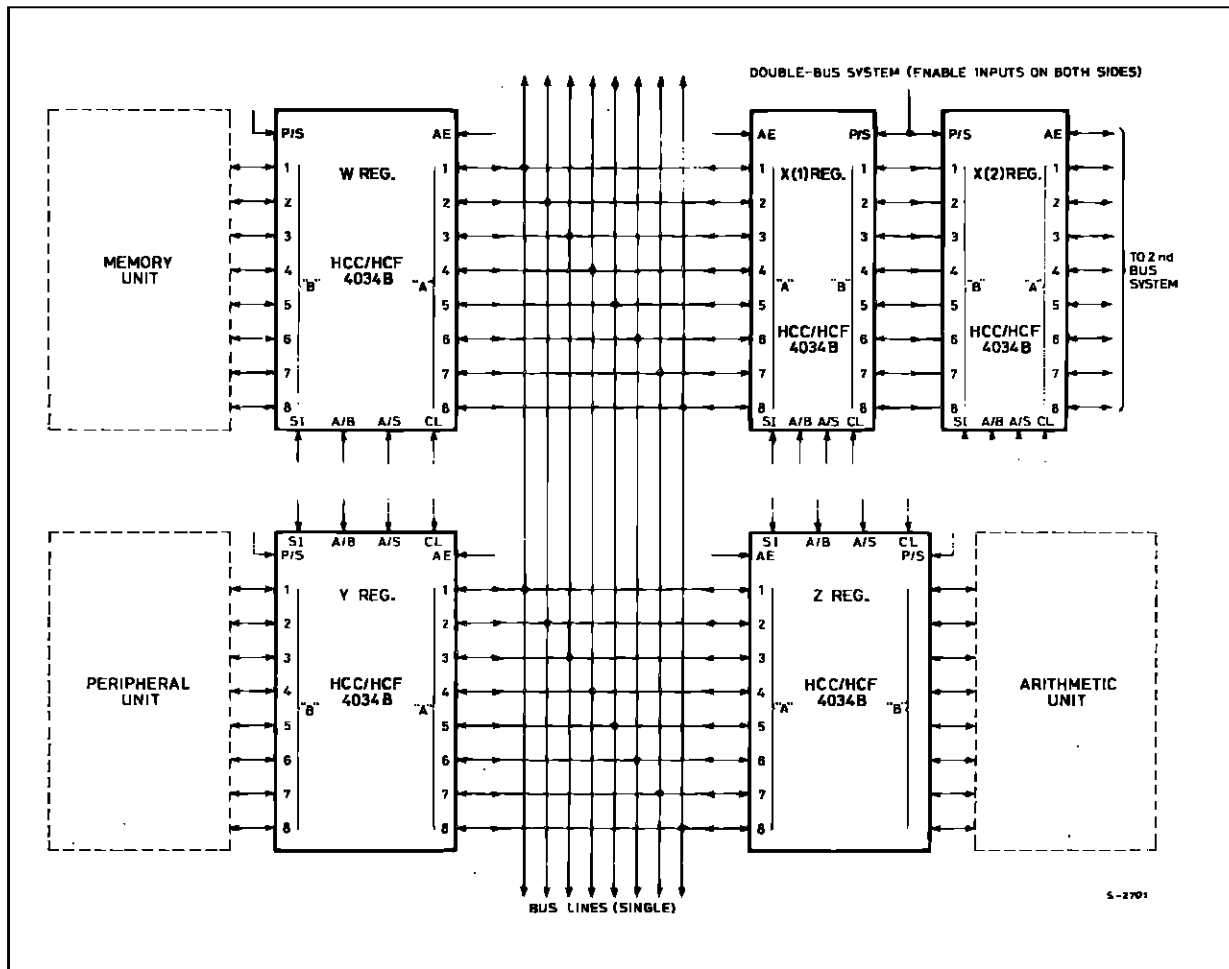

The "A" enable (AE) and A/B signals control all combinations of transfer between the registers and bus systems.

TEST CIRCUITS

Quiescent Device Current.

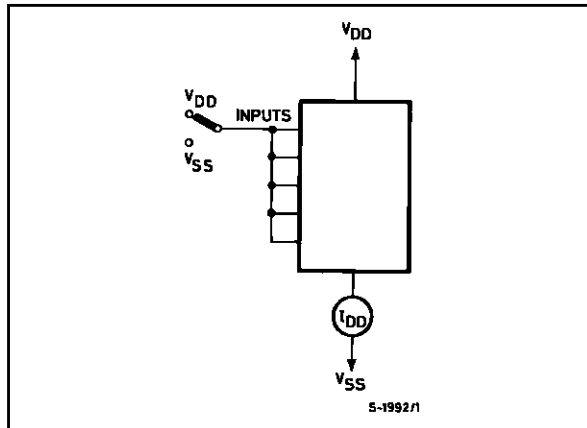

Noise Immunity.

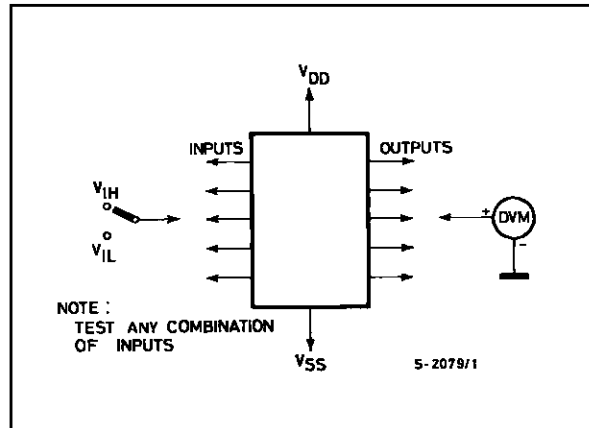

Input Leakage Current.

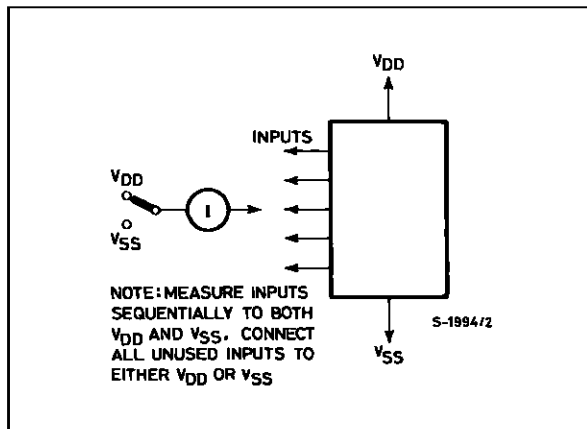

Plastic DIP24 (0.25) MECHANICAL DATA

DIM.	mm			inch		
	MIN.	TYP.	MAX.	MIN.	TYP.	MAX.
a1		0.63			0.025	
b		0.45			0.018	
b1	0.23		0.31	0.009		0.012
b2		1.27			0.050	
D			32.2			1.268
E	15.2		16.68	0.598		0.657
e		2.54			0.100	
e3		27.94			1.100	
F			14.1			0.555
l		4.445			0.175	
L		3.3			0.130	

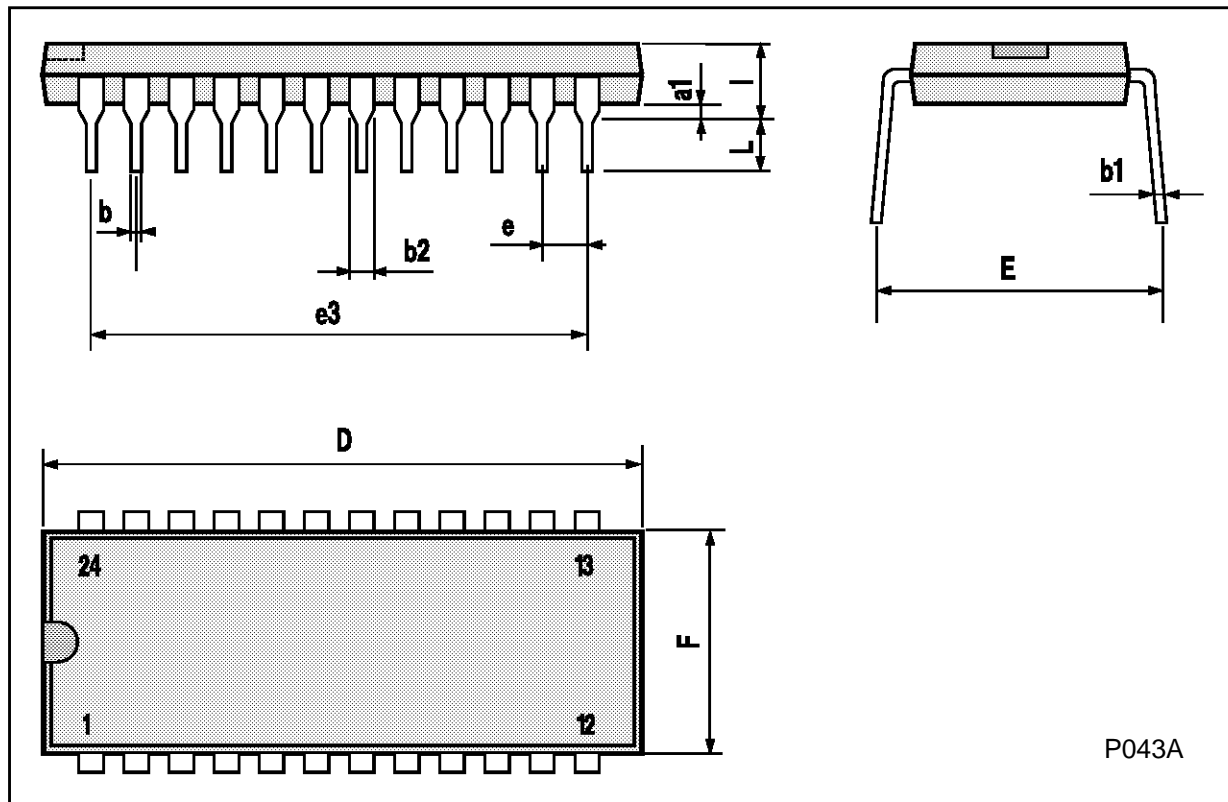

Ceramic DIP24 MECHANICAL DATA

DIM.	mm			inch		
	MIN.	TYP.	MAX.	MIN.	TYP.	MAX.
A			32.3			1.272
B	13.05		13.36	0.514		0.526
C	3.9		5.08	0.154		0.200
D	3			0.118		
E	0.5		1.78	0.020		0.070
e3		27.94			1.100	
F	2.29		2.79	0.090		0.110
G	0.4		0.55	0.016		0.022
I	1.17		1.52	0.046		0.060
L	0.22		0.31	0.009		0.012
M	1.52		2.49	0.060		0.098
N1	4° (min.), 15° (max.)					
P	15.4		15.8	0.606		0.622
Q			5.71			0.225

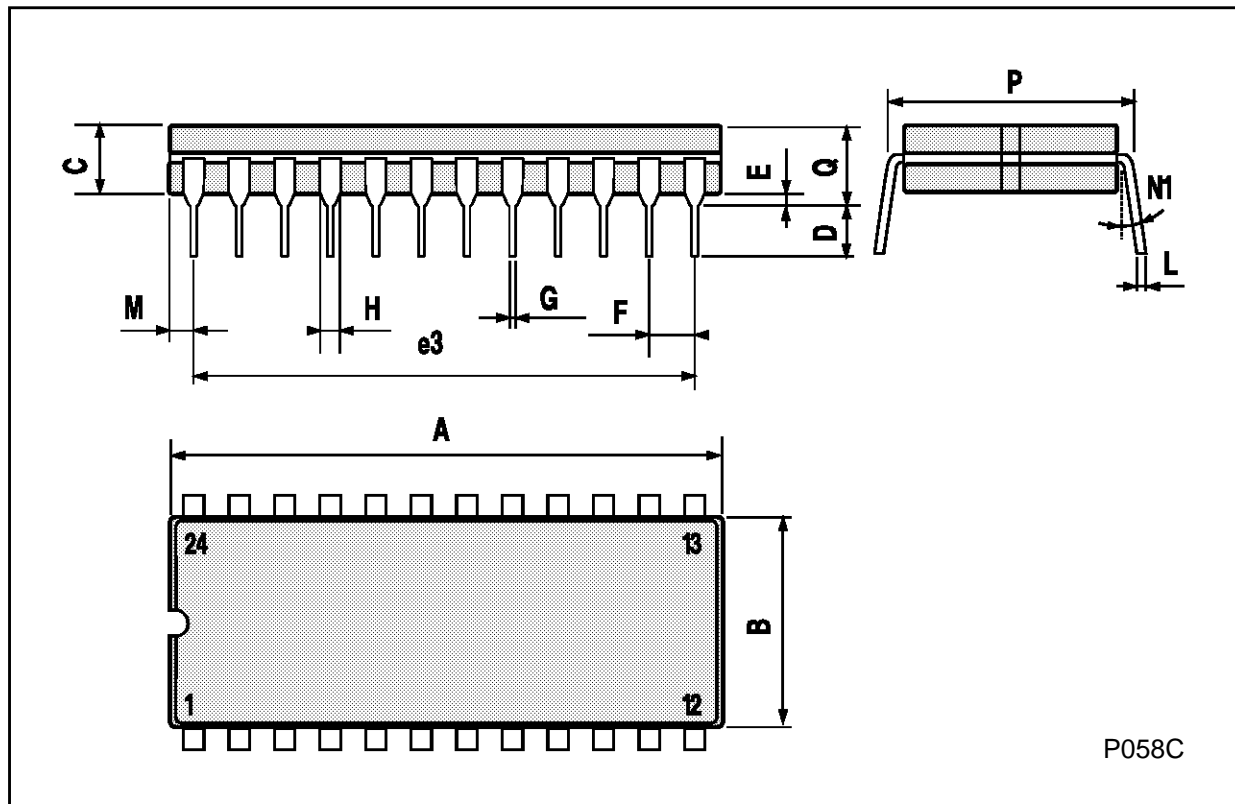

SO24 MECHANICAL DATA

DIM.	mm			inch		
	MIN.	TYP.	MAX.	MIN.	TYP.	MAX.
A			2.65			0.104
a1	0.10		0.20	0.004		0.007
a2			2.45			0.096
b	0.35		0.49	0.013		0.019
b1	0.23		0.32	0.009		0.012
C		0.50			0.020	
c1	45° (typ.)					
D	15.20		15.60	0.598		0.614
E	10.00		10.65	0.393		0.420
e		1.27			0.05	
e3		13.97			0.55	
F	7.40		7.60	0.291		0.299
L	0.50		1.27	0.19		0.050
S	8° (max.)					

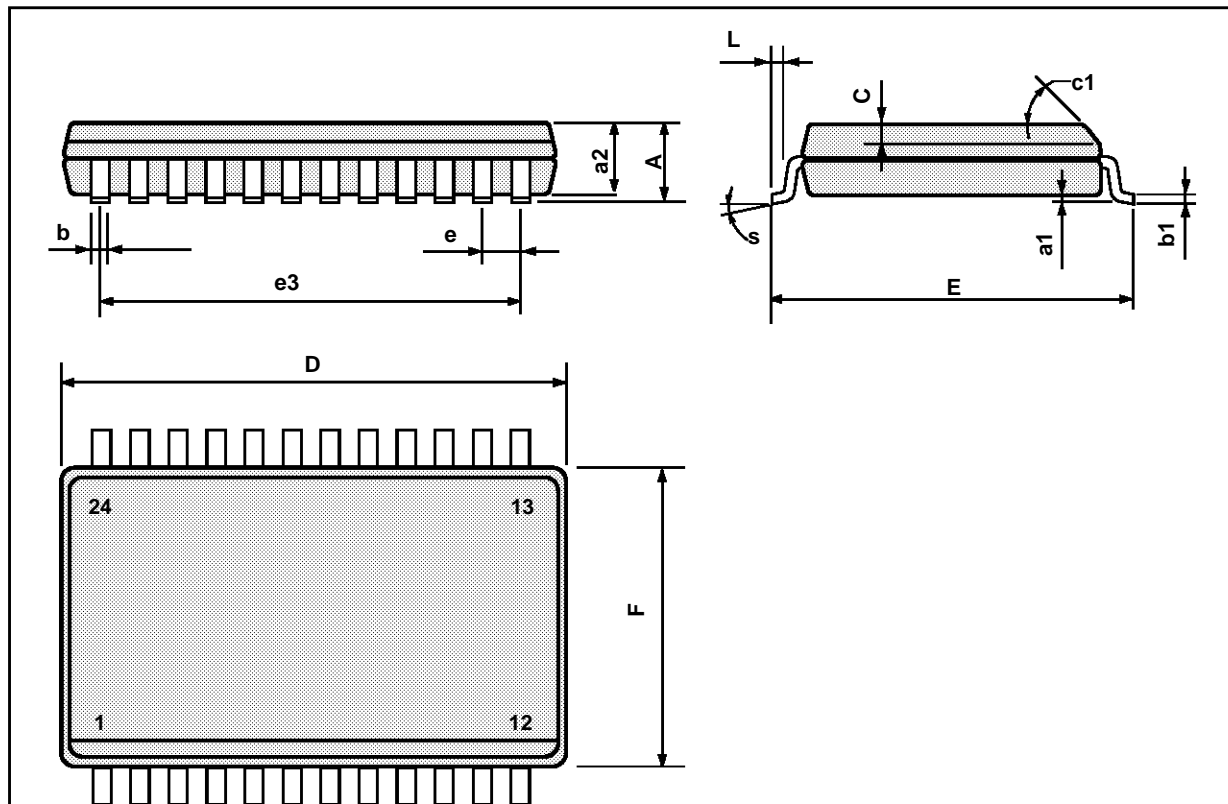

Information furnished is believed to be accurate and reliable. However, SGS-THOMSON Microelectronics assumes no responsibility for the consequences of use of such information nor for any infringement of patents or other rights of third parties which may result from its use. No license is granted by implication or otherwise under any patent or patent rights of SGS-THOMSON Microelectronics. Specifications mentioned in this publication are subject to change without notice. This publication supersedes and replaces all information previously supplied. SGS-THOMSON Microelectronics products are not authorized for use as critical components in life support devices or systems without express written approval of SGS-THOMSON Microelectronics.

© 1994 SGS-THOMSON Microelectronics - All Rights Reserved

SGS-THOMSON Microelectronics GROUP OF COMPANIES

Australia - Brazil - France - Germany - Hong Kong - Italy - Japan - Korea - Malaysia - Malta - Morocco - The Netherlands -
Singapore - Spain - Sweden - Switzerland - Taiwan - Thailand - United Kingdom - U.S.A