

**QUAD 3-STATE R-S LATCHES**

**QUAD NOR R-S LATCH-4043B**  
**QUAD NAND R-S LATCH-4044B**

- QUIESCENT CURRENT SPECIFIED TO 20V FOR HCC DEVICE
- 3-LEVEL OUTPUTS WITH COMMON OUTPUT ENABLE
- SEPARATE SET AND RESET INPUT FOR EACH LATCH
- 5V, 10V, AND 15V PARAMETRIC RATINGS
- NOR AND NAND CONFIGURATIONS
- INPUT CURRENT OF 100nA AT 18V AND 25°C FOR HCC DEVICE
- 100% TESTED FOR QUIESCENT CURRENT
- MEETS ALL REQUIREMENTS OF JEDEC TENTATIVE STANDARD N° 13A, "STANDARD SPECIFICATIONS FOR DESCRIPTION OF "B" SERIES CMOS DEVICES"

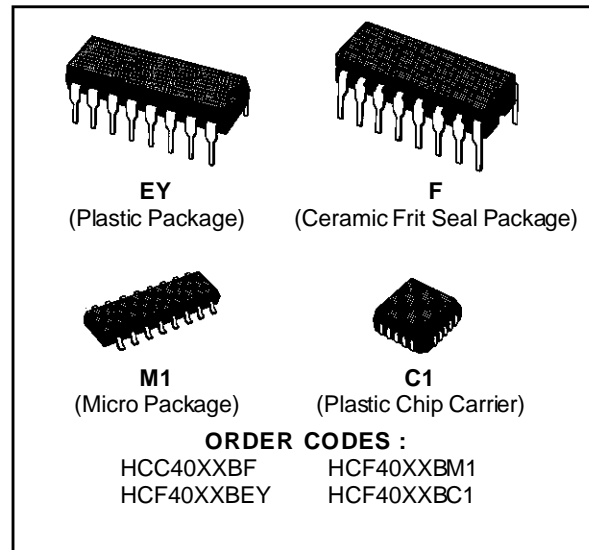

**DESCRIPTION**

The **HCC4043B**, **HCC4044B**, (extended temperature range) and the **HCF4043B**, **HCF4044B** (intermediate temperature range) are monolithic integrated circuits, available in 16-lead dual in-line plastic or ceramic package and plastic micropackage. The **HCC/HCF4043B** types are quad cross-coupled 3-state COS/MOS NOR latches and the **HCC/HCF4044B** types are quad cross-coupled 3-state COS/MOS NAND latches. Each latch has a separate Q output and individual SET and RESET inputs. The Q outputs are controlled by a common ENABLE input. A logic "1" or "high" on the ENABLE input connects the latch states to the Q outputs. A logic "0" or "low" on the ENABLE input disconnects the latch states from the Q outputs, resulting in an open circuit condition on the Q outputs. The open circuit feature allows common bussing of the outputs.

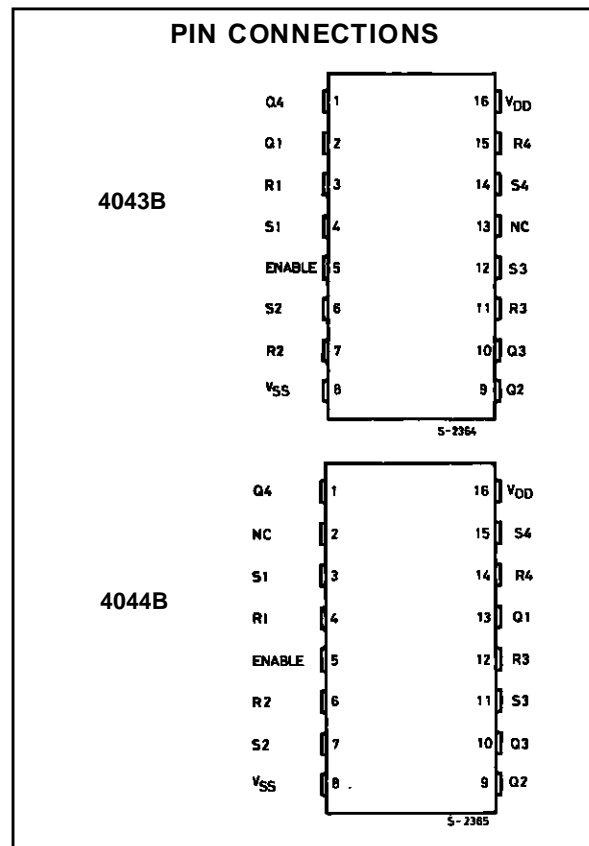

# HCC/HCF4043B/4044B

## FUNCTIONAL DIAGRAMS

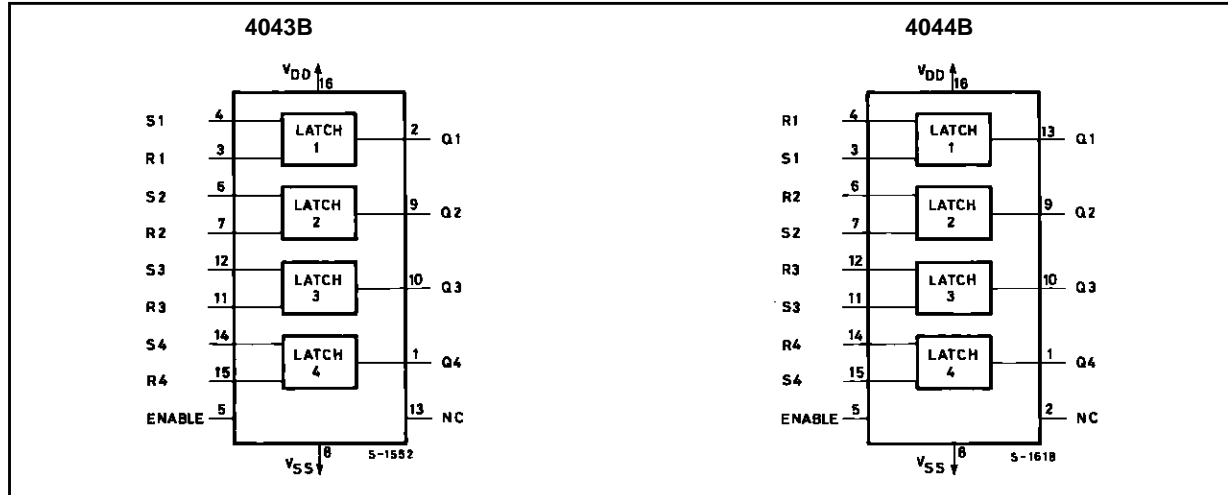

## ABSOLUTE MAXIMUM RATINGS

Symbol	Parameter	Value	Unit
$V_{DD}^*$	Supply Voltage : HCC Types HCF Types	- 0.5 to + 20 - 0.5 to + 18	V
$V_i$	Input Voltage	- 0.5 to $V_{DD} + 0.5$	V
$I_i$	DC Input Current (any one input)	$\pm 10$	mA
$P_{tot}$	Total Power Dissipation (per package) Dissipation per Output Transistor for $T_{op}$ = Full Package-temperature Range	200 100	mW mW
$T_{op}$	Operating Temperature : HCC Types HCF Types	- 55 to + 125 - 40 to + 85	$^{\circ}C$ $^{\circ}C$
$T_{stg}$	Storage Temperature	- 65 to + 150	$^{\circ}C$

Stresses above those listed under "Absolute Maximum Ratings" may cause permanent damage to the device. This is a stress rating only and functional operation of the device at these or any other conditions above those indicated in the operational sections of this specification is not implied. Exposure to absolute maximum rating conditions for external periods may affect device reliability.

\* All voltage values are referred to  $V_{ss}$  pin voltage.

## RECOMMENDED OPERATING CONDITIONS

Symbol	Parameter	Value	Unit
$V_{DD}$	Supply Voltage : HCC Types HCF Types	3 to 18 3 to 15	V V
$V_i$	Input Voltage	0 to $V_{DD}$	V
$T_{op}$	Operating Temperature : HCC Types HCF Types	- 55 to + 125 - 40 to + 85	$^{\circ}C$ $^{\circ}C$

LOGIC DIAGRAMS

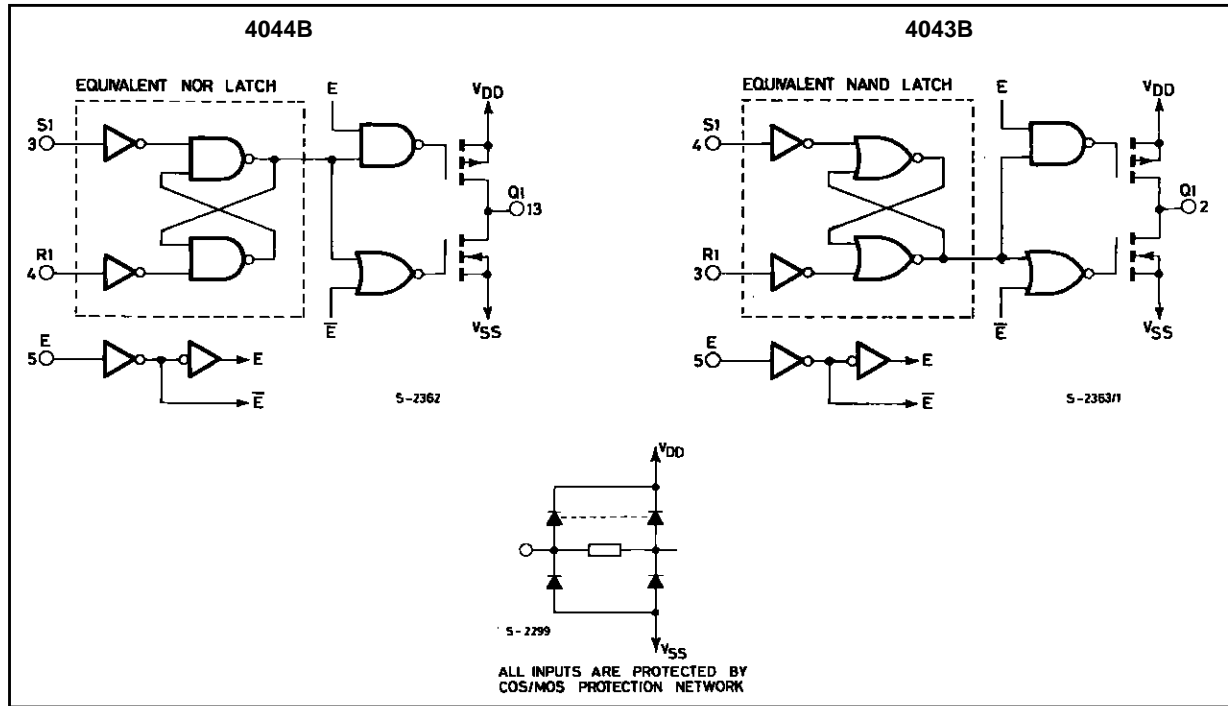

STATIC ELECTRICAL CHARACTERISTICS (over recommended operating conditions)

Symbol	Parameter	Test Conditions				Value						Unit		
		V <sub>I</sub> (V)	V <sub>O</sub> (V)	I <sub>O</sub>   ( $\mu$ A)	V <sub>DD</sub> (V)	T <sub>Low</sub> *		25°C			T <sub>High</sub> *			
						Min.	Max.	Min.	Typ.	Max.	Min.		Max.	
I <sub>L</sub>	Quiescent Current	HCC Types	0/ 5			5		1	0.02	1		30	$\mu$ A	
			0/10			10		2	0.02	2		60		
			0/15			15		4	0.02	4		120		
			0/20			20		20	0.04	20		600		
			HCF Types	0/ 5			5		4	0.02	4			30
				0/10			10		8	0.02	8			60
0/15				15		16	0.02	16		120				
V <sub>OH</sub>	Output High Voltage	0/ 5	< 1	5	4.95		4.95			4.95		V		
		0/10	< 1	10	9.95		9.95			9.95				
		0/15	< 1	15	14.95		14.95			14.95				
V <sub>OL</sub>	Output Low Voltage	5/0	< 1	5		0.05			0.05		0.05	V		
		10/0	< 1	10		0.05			0.05		0.05			
		15/0	< 1	15		0.05			0.05		0.05			
V <sub>IH</sub>	Input High Voltage		0.5/4.5	< 1	5	3.5		3.5			3.5	V		
			1/9	< 1	10	7		7			7			
			1.5/13.5	< 1	15	11		11			11			

\* T<sub>Low</sub> = - 55°C for HCC device : - 40°C for HCF device.

\* T<sub>High</sub> = + 125°C for HCC device : + 85°C for HCF device.

The Noise Margin for both "1" and "0" level is : 1V min. with V<sub>DD</sub> = 5V, 2V min. with V<sub>DD</sub> = 10V, 2.5V min. with V<sub>DD</sub> = 15V.

**STATIC ELECTRICAL CHARACTERISTICS** (continued)

Symbol	Parameter		Test Conditions				Value						Unit	
			V <sub>I</sub> (V)	V <sub>O</sub> (V)	I <sub>O</sub>   ( $\mu$ A)	V <sub>DD</sub> (V)	T <sub>Low</sub> *		25°C			T <sub>High</sub> *		
							Min.	Max.	Min.	Typ.	Max.	Min.		Max.
V <sub>IL</sub>	Input Low Voltage			4.5/0.5	< 1	5		1.5			1.5		1.5	V
				9/1	< 1	10		3			3		3	
				13.5/1.5	< 1	15		4			4		4	
I <sub>OH</sub>	Output Drive Current	HCC Types	0/ 5	2.5		5	- 2		- 1.6	- 3.2		- 1.15		mA
			0/ 5	4.6		5	- 0.64		- 0.51	- 1		- 0.36		
			0/10	9.5		10	- 1.6		- 1.3	- 2.6		- 0.9		
			0/15	13.5		15	- 4.2		- 3.4	- 6.8		- 2.4		
		HCF Types	0/ 5	2.5		5	- 1.53		- 1.36	- 3.2		- 1.1		
			0/ 5	4.6		5	- 0.52		- 0.44	- 1		- 0.36		
			0/10	9.5		10	- 1.3		- 1.1	- 2.6		- 0.9		
			0/15	13.5		15	- 3.6		- 3.0	- 6.8		- 2.4		
I <sub>OL</sub>	Output Sink Current	HCC Types	0/ 5	0.4		5	0.64		0.51	1		0.36	mA	
			0/10	0.5		10	1.6		1.3	2.6		0.9		
			0/15	1.5		15	4.2		3.4	6.8		2.4		
		HCF Types	0/ 5	0.4		5	0.52		0.44	1		0.36		
			0/10	0.5		10	1.3		1.1	2.6		0.9		
			0/15	1.5		15	3.6		3.0	6.8		2.4		
I <sub>IH</sub> , I <sub>IL</sub>	Input leakage Current	HCC Types	0/18	Any Input		18		$\pm$ 0.1		$\pm$ 10 <sup>-5</sup>	$\pm$ 0.1		$\pm$ 1	$\mu$ A
		HCF Types	0/15			15		$\pm$ 0.3		$\pm$ 10 <sup>-5</sup>	$\pm$ 0.3		$\pm$ 1	
I <sub>OH</sub>	3-state Output	HCC Types	0/18	0/18		18		$\pm$ 0.4		$\pm$ 10 <sup>-4</sup>	$\pm$ 0.4		$\pm$ 12	$\mu$ A
		HCF Types	0/15	0/15		15		$\pm$ 1.0		$\pm$ 10 <sup>-4</sup>	$\pm$ 1.0		$\pm$ 7.5	
C <sub>I</sub>	Input Capacitance		Any Input						5	7.5			pF	

\* T<sub>Low</sub> = - 55°C for HCC device : - 40°C for HCF device.

\* T<sub>High</sub> = + 125°C for HCC device : + 85°C for HCF device.

The Noise Margin for both "1" and "0" level is : 1V min. with V<sub>DD</sub> = 5V, 2V min. with V<sub>DD</sub> = 10V, 2.5V min. with V<sub>DD</sub> = 15V.

**DYNAMIC ELECTRICAL CHARACTERISTICS** (T<sub>amb</sub> = 25°C, C<sub>L</sub> = 50pF, R<sub>L</sub> = 200k $\Omega$ , typical temperature coefficient for all V<sub>DD</sub> values is 0.3%/°C, all input rise and fall times = 20ns)

Symbol	Parameter	Test Conditions		Value			Unit
			V <sub>DD</sub> (V)	Min.	Typ.	Max.	
t <sub>PLH</sub> , t <sub>PHL</sub>	Propagation Delay Time (SET or RESET to Q)		5		150	300	ns
			10		70	140	
			15		50	100	
t <sub>PZH</sub> , t <sub>PHZ</sub>	3-state Propagation Delay Time (ENABLE to Q)		5		115	230	ns
			10		55	110	
			15		40	80	

**DYNAMIC ELECTRICAL CHARACTERISTICS** (continued)

Symbol	Parameter	Test Conditions		Value			Unit
			V <sub>DD</sub> (V)	Min.	Typ.	Max.	
t <sub>PLZ</sub> , t <sub>PZL</sub>	Propagation Delay Time		5		90	180	ns
			10		50	100	
			15		35	70	
t <sub>TLH</sub> , t <sub>THL</sub>	Transition Time		5		100	200	ns
			10		50	100	
			15		40	80	
t <sub>w</sub>	Pulse Width (SET or RESET)		5	160	80		ns
			10	80	40		
			15	40	20		

Typical Output Low (sink) Current.

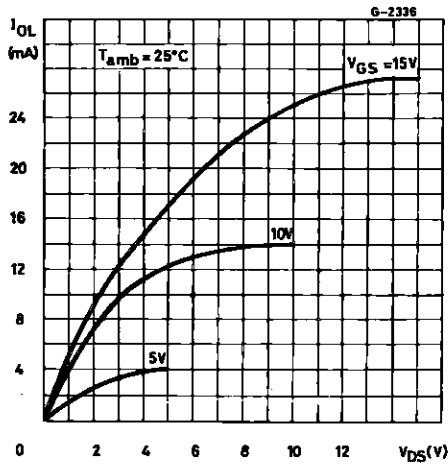

Minimum Output Low (sink) Current Characteristics.

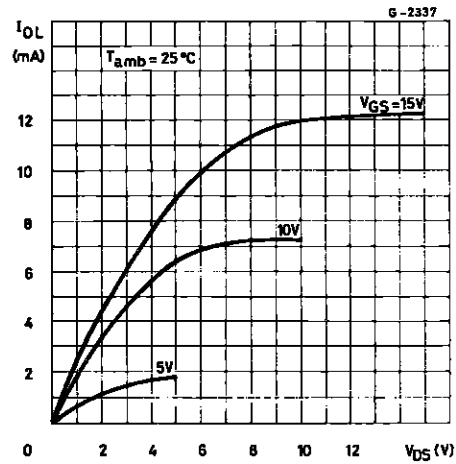

Typical Output High (source) Current Characteristics.

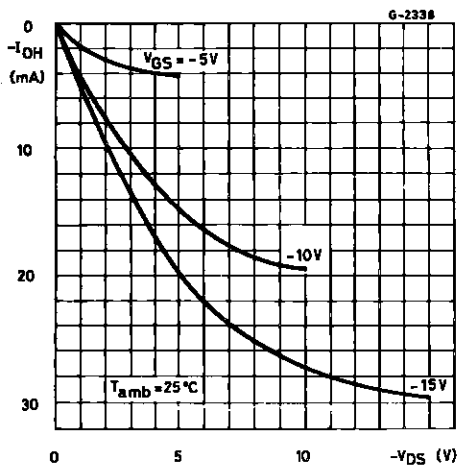

Minimum Output High (source) Current Characteristics.

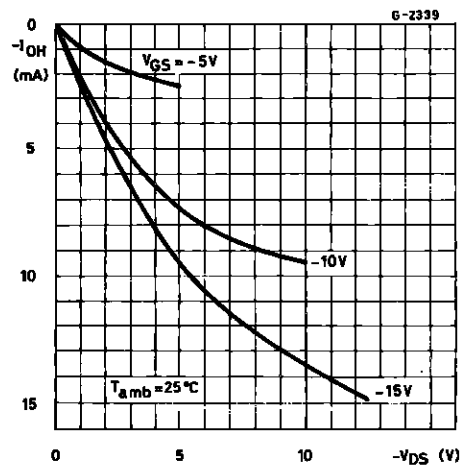

# HCC/HCF4043B/4044B

Typical Transition Time vs. Load Capacitance.

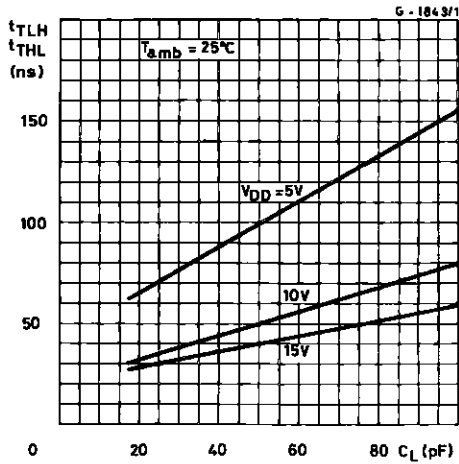

Typical Propagation Delay Time vs. Load Capacitance (SET, RESET to Q,  $\bar{Q}$ ).

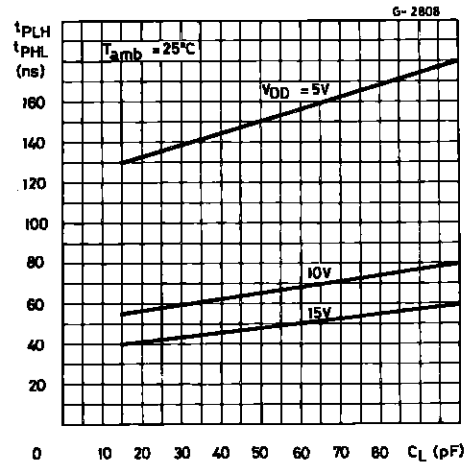

Typical Power Dissipation/device vs. Frequency.

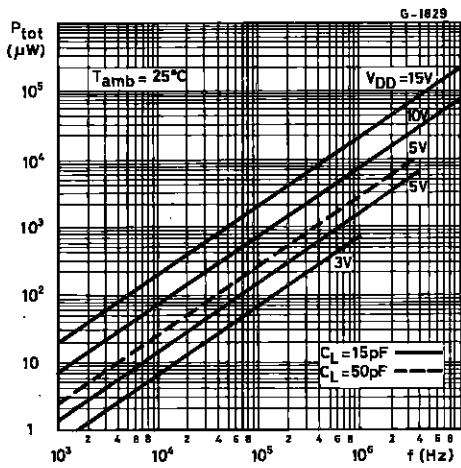

Switch Bounce Eliminator.

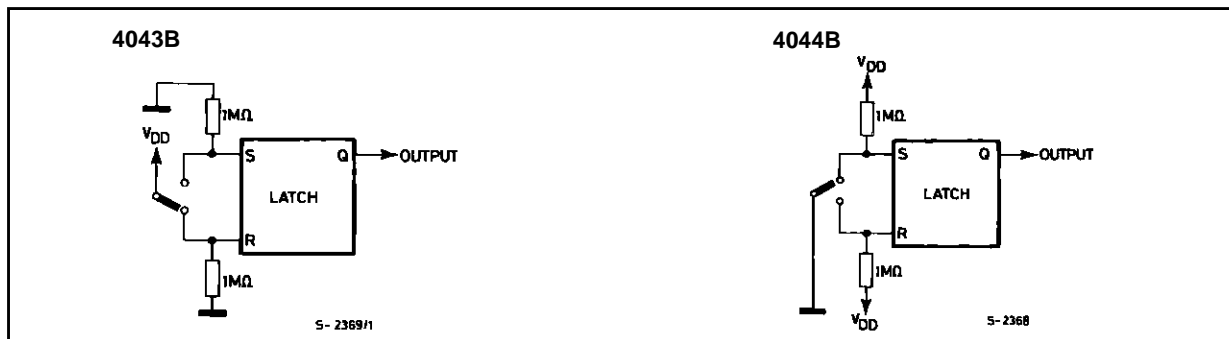

APPLICATIONS

MULTIPLE BUS STORAGE.

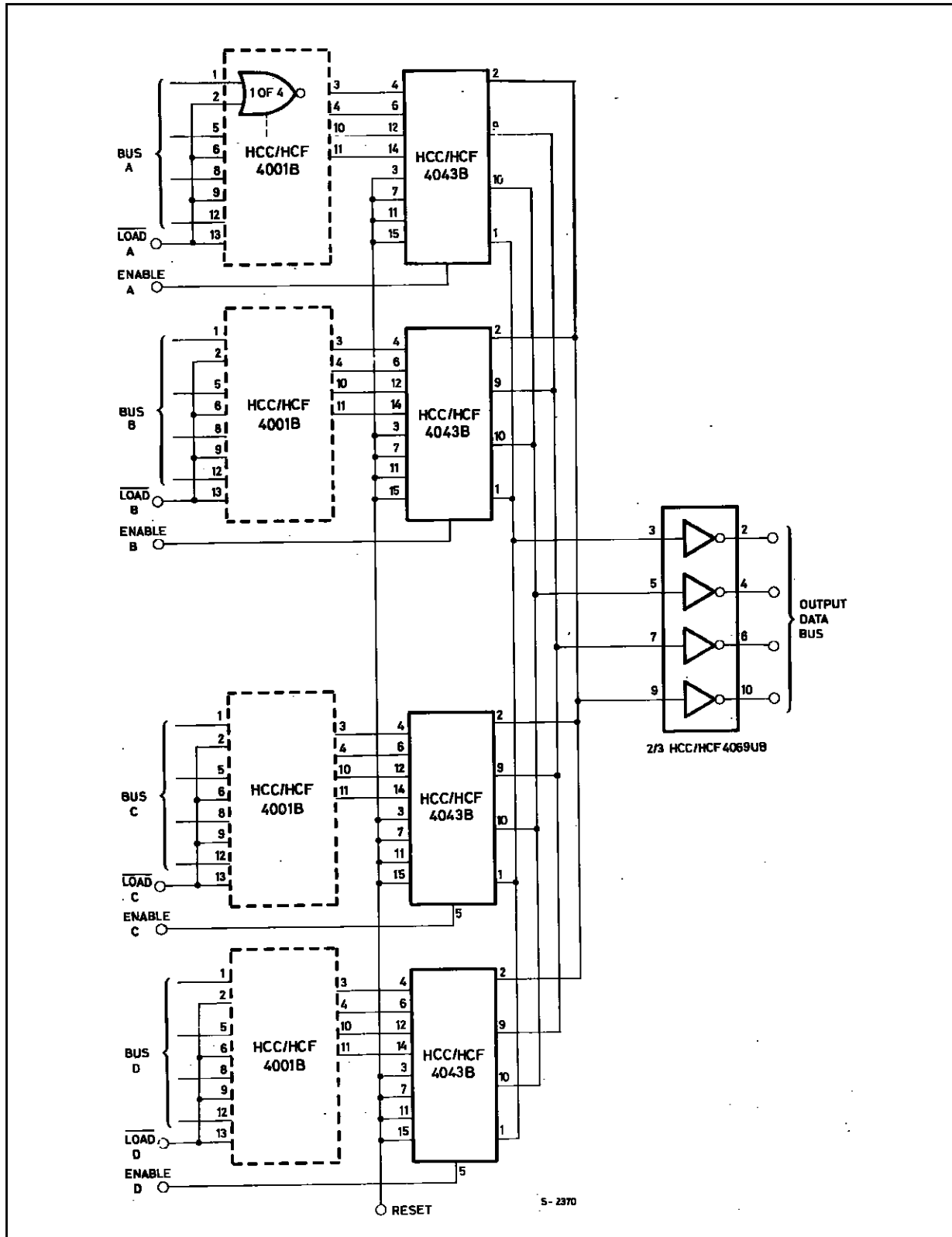

TEST CIRCUITS

Quiescent Device Current.

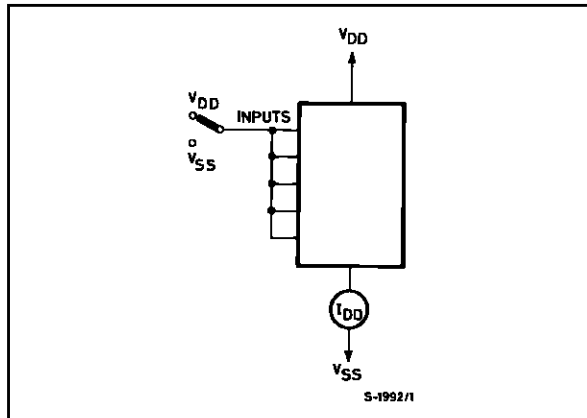

Input Voltage.

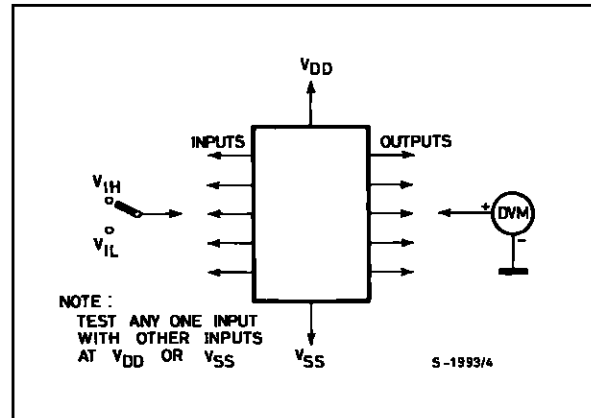

Input Current.

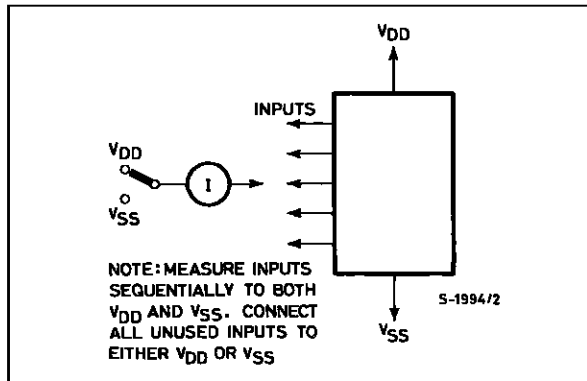

Enable Propagation Delay Time and Waveforms.

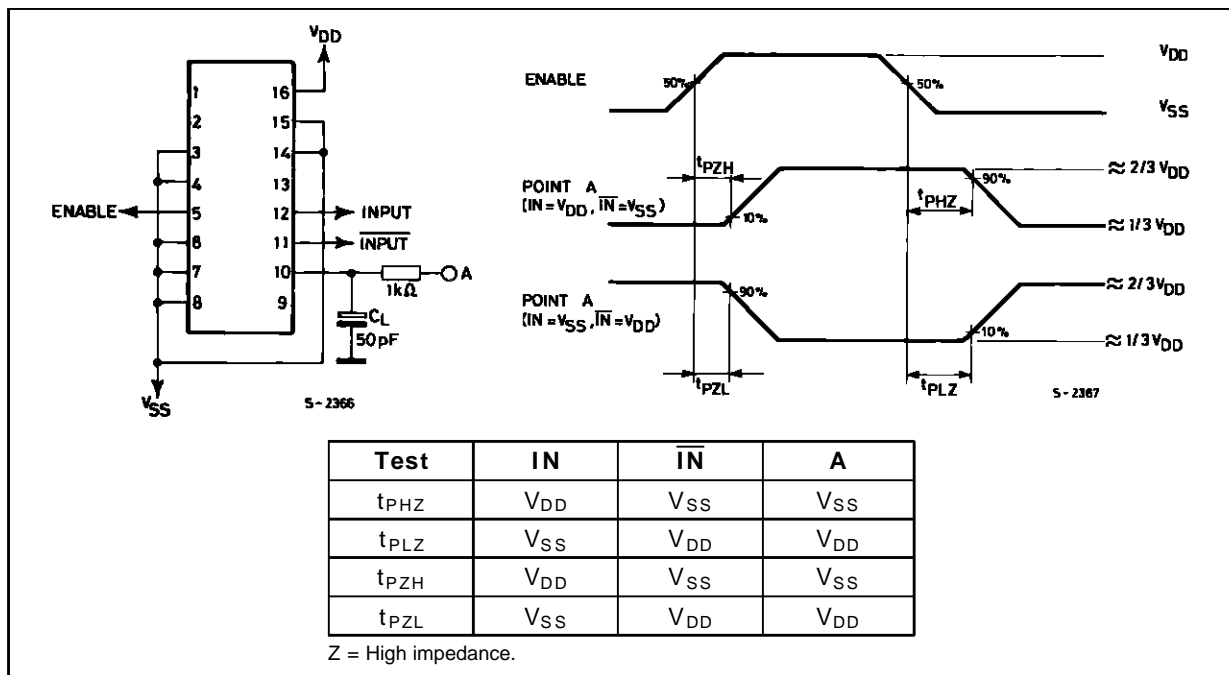

**Plastic DIP16 (0.25) MECHANICAL DATA**

DIM.	mm			inch		
	MIN.	TYP.	MAX.	MIN.	TYP.	MAX.
a1	0.51			0.020		
B	0.77		1.65	0.030		0.065
b		0.5			0.020	
b1		0.25			0.010	
D			20			0.787
E		8.5			0.335	
e		2.54			0.100	
e3		17.78			0.700	
F			7.1			0.280
I			5.1			0.201
L		3.3			0.130	
Z			1.27			0.050

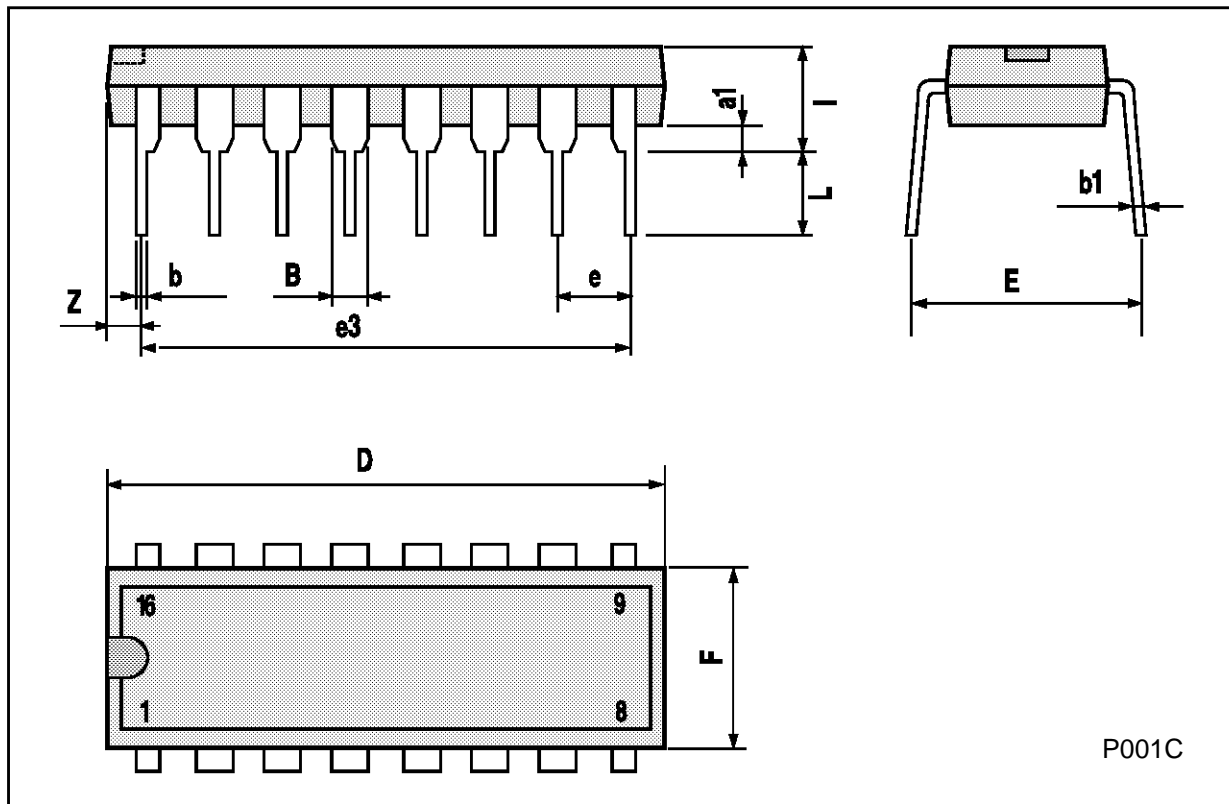

**Ceramic DIP16/1 MECHANICAL DATA**

DIM.	mm			inch		
	MIN.	TYP.	MAX.	MIN.	TYP.	MAX.
A			20			0.787
B			7			0.276
D		3.3			0.130	
E	0.38			0.015		
e3		17.78			0.700	
F	2.29		2.79	0.090		0.110
G	0.4		0.55	0.016		0.022
H	1.17		1.52	0.046		0.060
L	0.22		0.31	0.009		0.012
M	0.51		1.27	0.020		0.050
N			10.3			0.406
P	7.8		8.05	0.307		0.317
Q			5.08			0.200



**SO16 (Narrow) MECHANICAL DATA**

DIM.	mm			inch		
	MIN.	TYP.	MAX.	MIN.	TYP.	MAX.
A			1.75			0.068
a1	0.1		0.2	0.004		0.007
a2			1.65			0.064
b	0.35		0.46	0.013		0.018
b1	0.19		0.25	0.007		0.010
C		0.5			0.019	
c1	45° (typ.)					
D	9.8		10	0.385		0.393
E	5.8		6.2	0.228		0.244
e		1.27			0.050	
e3		8.89			0.350	
F	3.8		4.0	0.149		0.157
G	4.6		5.3	0.181		0.208
L	0.5		1.27	0.019		0.050
M			0.62			0.024
S	8° (max.)					

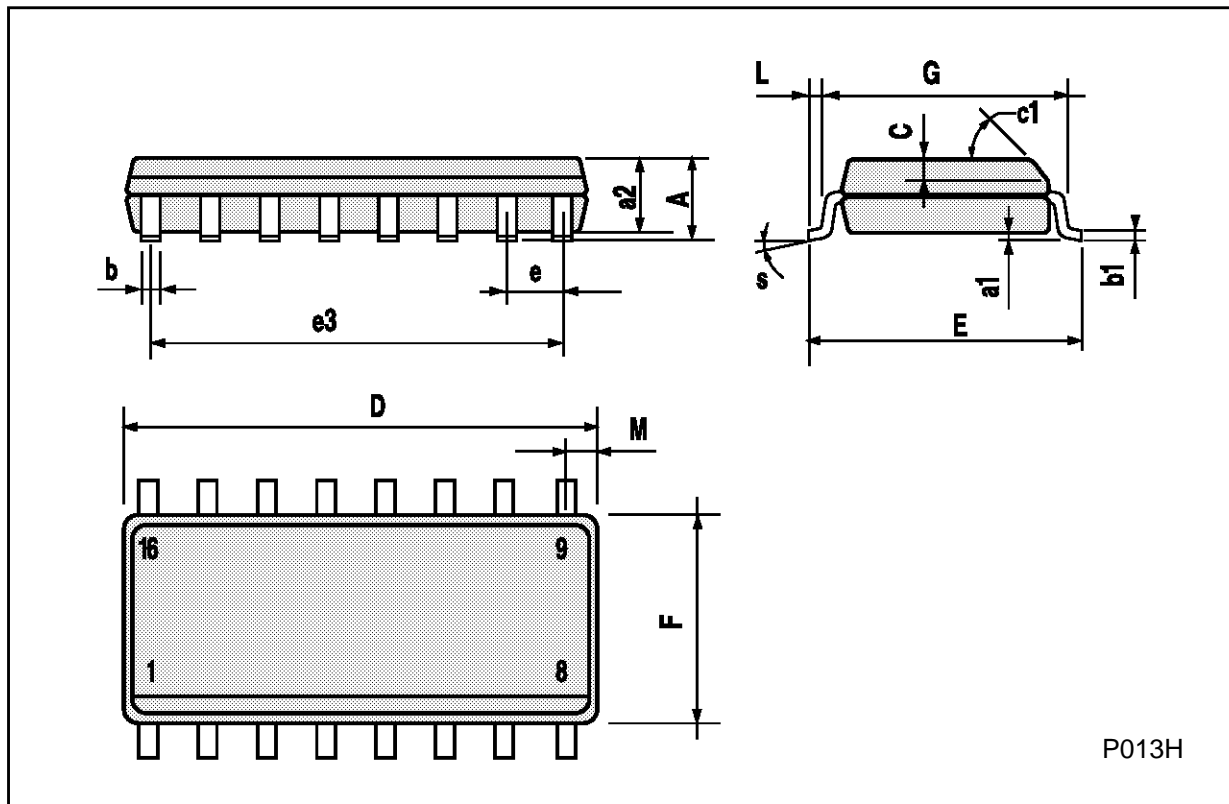

P013H

**PLCC20 MECHANICAL DATA**

DIM.	mm			inch		
	MIN.	TYP.	MAX.	MIN.	TYP.	MAX.
A	9.78		10.03	0.385		0.395
B	8.89		9.04	0.350		0.356
D	4.2		4.57	0.165		0.180
d1		2.54			0.100	
d2		0.56			0.022	
E	7.37		8.38	0.290		0.330
e		1.27			0.050	
e3		5.08			0.200	
F		0.38			0.015	
G			0.101			0.004
M		1.27			0.050	
M1		1.14			0.045	

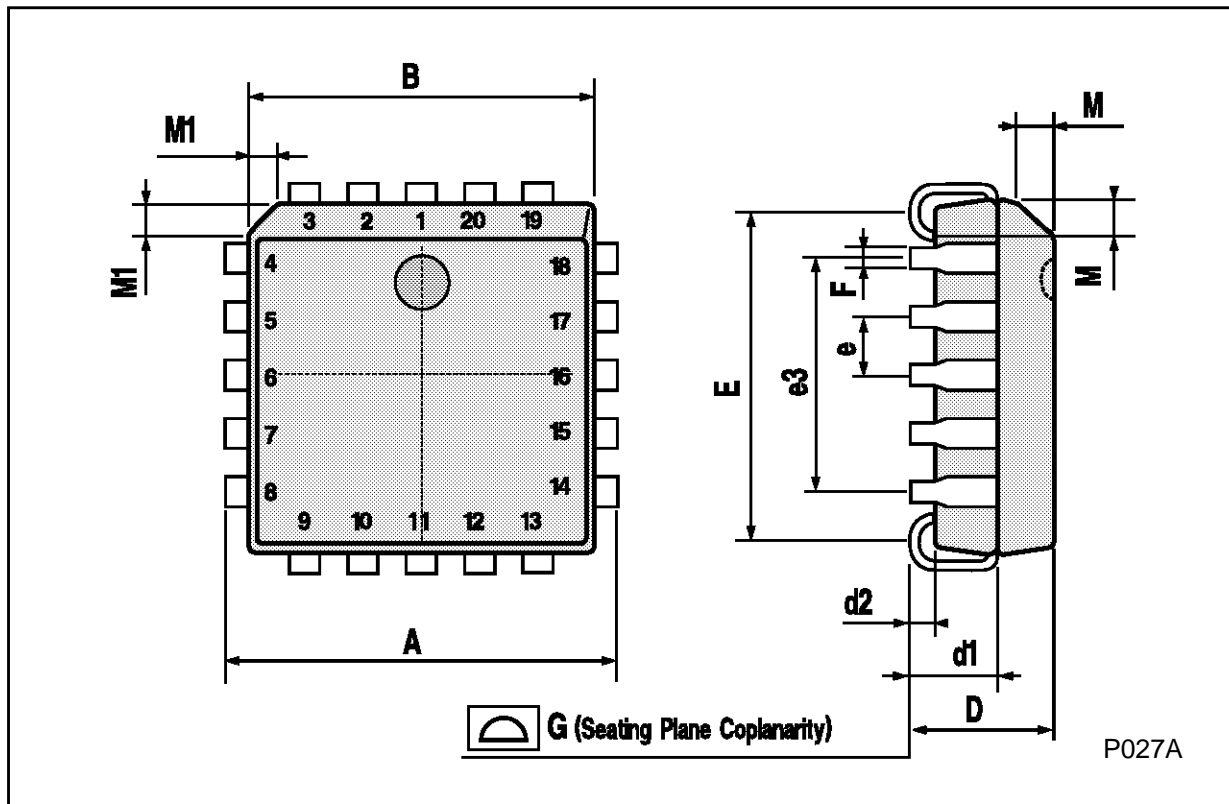

Information furnished is believed to be accurate and reliable. However, SGS-THOMSON Microelectronics assumes no responsibility for the consequences of use of such information nor for any infringement of patents or other rights of third parties which may result from its use. No license is granted by implication or otherwise under any patent or patent rights of SGS-THOMSON Microelectronics. Specifications mentioned in this publication are subject to change without notice. This publication supersedes and replaces all information previously supplied. SGS-THOMSON Microelectronics products are not authorized for use as critical components in life support devices or systems without express written approval of SGS-THOMSON Microelectronics.

© 1994 SGS-THOMSON Microelectronics - All Rights Reserved

SGS-THOMSON Microelectronics GROUP OF COMPANIES

Australia - Brazil - France - Germany - Hong Kong - Italy - Japan - Korea - Malaysia - Malta - Morocco - The Netherlands -  
Singapore - Spain - Sweden - Switzerland - Taiwan - Thailand - United Kingdom - U.S.A