

**14-STAGE RIPPLE CARRY BINARY  
COUNTER/DIVIDER AND OSCILLATOR**

- MEDIUM-SPEED OPERATION
- COMMON RESET
- FULLY STATIC OPERATION
- BUFFERED INPUTS AND OUTPUTS
- QUIESCENT CURRENT SPECIFIED TO 20V FOR HCC DEVICE
- 5V, 10V AND 15V PARAMETRIC RATINGS
- INPUT CURRENT OF 100nA AT 18V AND 25°C FOR HCC DEVICE
- 1005 TESTED FOR QUIESCENT CURRENT
- MEETS ALL REQUIREMENTS OF JEDEC TENTATIVE STANDARD N. 13A, "STANDARD SPECIFICATIONS FOR DESCRIPTION OF 'B' SERIES CMOS DEVICES"

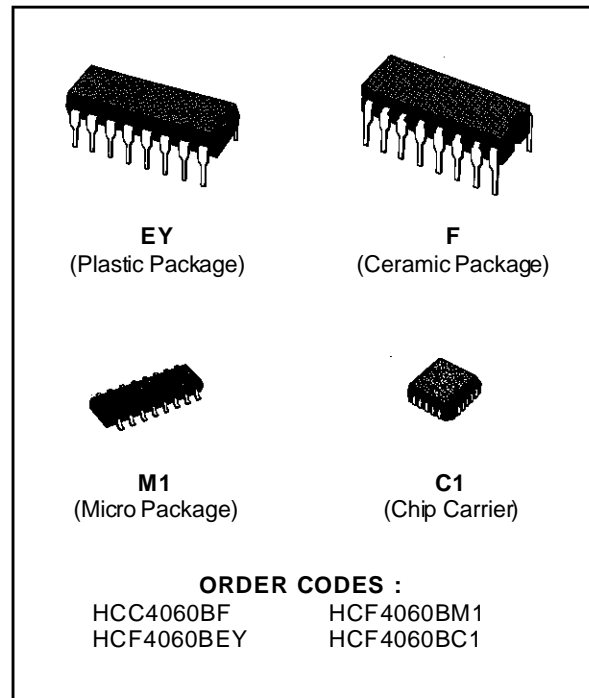

**DESCRIPTION**

The **HCC4060B** (extended temperature range) and **HCF4060B** (intermediate temperature range) are monolithic integrated circuit, available in 16-lead dual in line plastic or ceramic package and plastic micropackage. The **HCC/HCF4060B** consist of an oscillator section and 14 ripple carry binary counter stages. The oscillator configuration allows design of either RC or crystal oscillator circuits. A RESET input is provided which reset the counter to the all 0's state and disables oscillator. A high level on the RESET line accomplishes the reset function. All counter stages are master slave flip-flops. The state of the counter is advanced one step in binary order on the negative transition of  $\phi_1$  (and  $\phi_0$ ). All inputs and outputs are fully buffered. Schmitt trigger action on the clock lin permits unlimited clock rise and fall time.

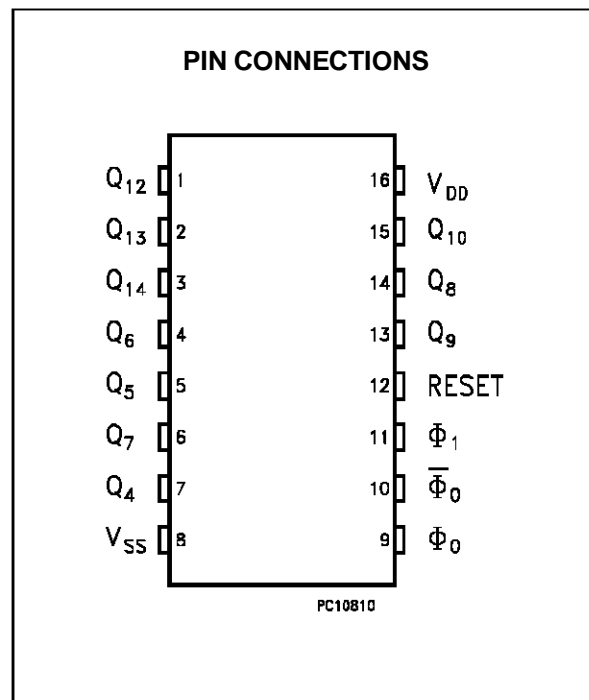

# HCC/HCF4060B

## FUNCTIONAL DIAGRAM

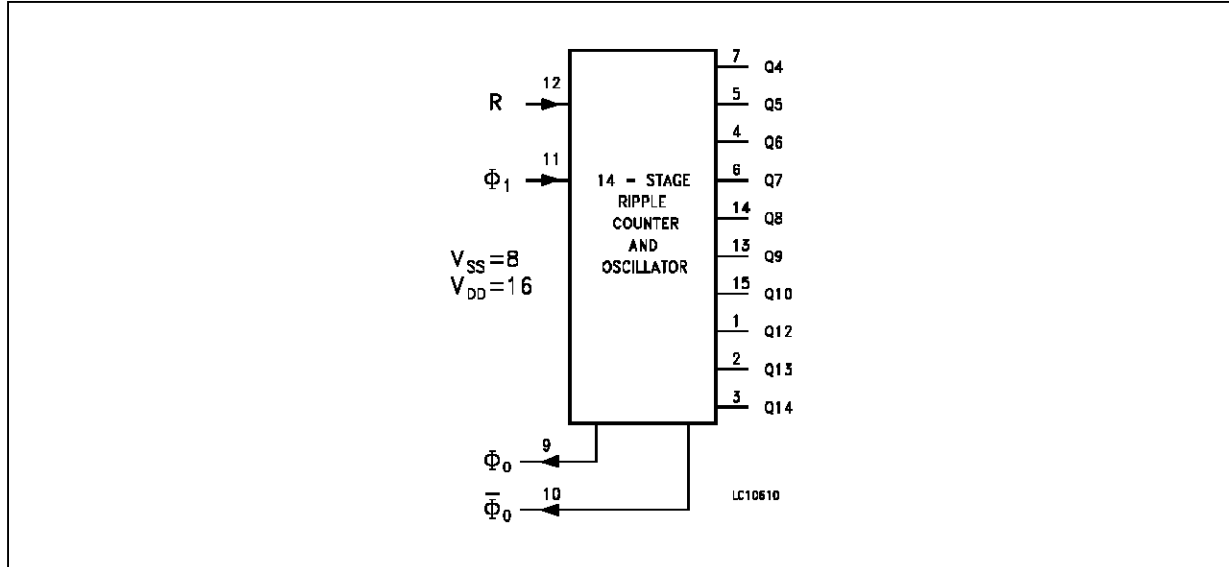

## ABSOLUTE MAXIMUM RATING

Symbol	Parameter	Value	Unit
$V_{DD}^*$	Supply Voltage: <b>HCC</b> Types <b>HCF</b> Types	-0.5 to +20 -0.5 to +18	V V
$V_i$	Input Voltage	-0.5 to $V_{DD} + 0.5$	V
$I_i$	DC Input Current (any one input)	$\pm 10$	mA
$P_{tot}$	Total Power Dissipation (per package) Dissipation per Output Transistor for Top = Full Package Temperature Range	200 100	mW mW
$T_{op}$	Operating Temperature: <b>HCC</b> Types <b>HCF</b> Types	-55 to +125 -40 to +85	$^{\circ}C$ $^{\circ}C$
$T_{stg}$	Storage Temperature	-65 to +150	$^{\circ}C$

Stresses above those listed under "Absolute Maximum Ratings" may cause permanent damage to the device. This is a stress rating only and functional operation of the device at these or any other conditions above those indicated in the operational sections of this specification is not implied. Exposure to absolute maximum rating conditions for external periods may affect device reliability.

\* All voltage values are referred to  $V_{SS}$  pin voltage.

## RECOMMENDED OPERATING CONDITIONS

Symbol	Parameter	Value	Unit
$V_{DD}$	Supply Voltage: <b>HCC</b> Types <b>HCF</b> Types	3 to 18 3 to 15	V V
$V_i$	Input Voltage	0 to $V_{DD}$	V
$T_{op}$	Operating Temperature: <b>HCC</b> Types <b>HCF</b> Types	-55 to +125 -40 to +85	$^{\circ}C$ $^{\circ}C$

LOGIC DIAGRAM

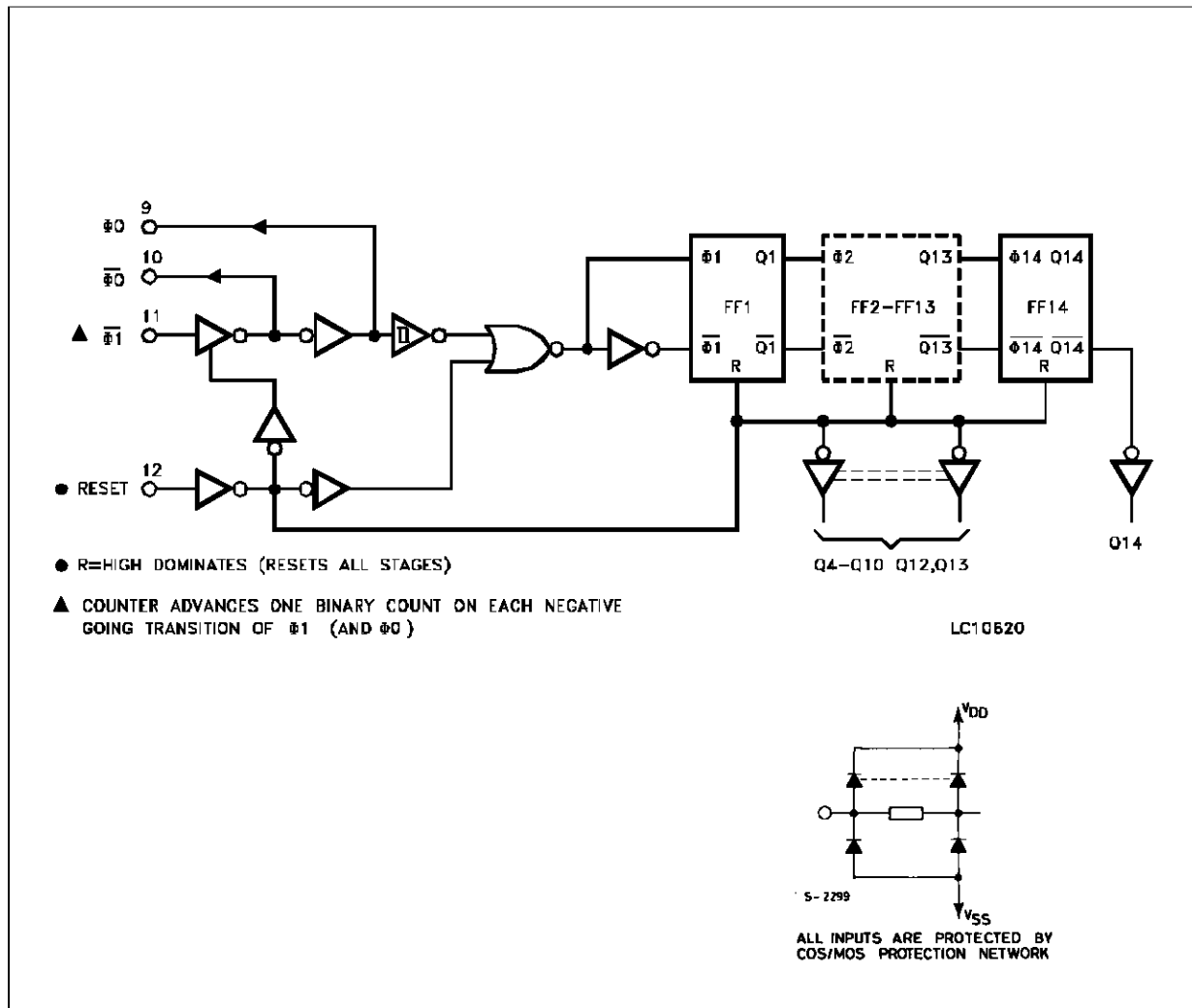

# HCC/HCF4060B

## STATIC ELECTRICAL CHARACTERISTICS (over recommended operating conditions)

Symbol	Parameter		Test Conditions				Value						Unit	
			V <sub>I</sub> (V)	V <sub>O</sub> (V)	I <sub>O</sub>   ( $\mu$ A)	V <sub>DD</sub> (V)	T <sub>LOW</sub> *		25 °C			T <sub>HIGH</sub> *		
							Min.	Max.	Min.	Typ.	Max.	Min.		Max.
I <sub>L</sub>	Quiescent Current	HCC Types	0/5			5		5		0.04	5		150	$\mu$ A
			0/10			10		10		0.04	10		300	
			0/15			15		20		0.04	20		600	
		0/20			20		100		0.08	100		3000		
		HCF Types	0/5			5		20		0.04	20		150	
			0/10			10		40		0.04	40		300	
0/15				15		80		0.04	80		600			
V <sub>OH</sub>	Output High Voltage	0/5		< 1	5	4.95		4.95			4.95		V	
		0/10		< 1	10	9.95		9.95			9.95			
		0/15		< 1	15	14.95		14.95			14.95			
V <sub>OL</sub>	Output Low Voltage	5/0		< 1	5		0.05			0.05		0.05	V	
		10/0		< 1	10		0.05			0.05		0.05		
		15/0		< 1	15		0.05			0.05		0.05		
V <sub>IH</sub>	Input High Voltage	0.5/4.5	< 1	5	3.5			3.5				3.5	V	
		1/9	< 1	10	7			7				7		
		1.5/13.5	< 1	15	11			11				11		
V <sub>IL</sub>	Input Low Voltage	4.5/0.5	< 1	5			1.5			1.5		1.5	V	
		9/1	< 1	10			3			3		3		
		13.5/1.5	< 1	15			4			4		4		
I <sub>OH</sub>	Output Drive Current	HCC Types	0/5	2.5		5	-2		-1.6	-3.2		-1.15	mA	
			0/5	4.6		5	-0.64		-0.51	-1		-0.36		
			0/10	9.5		10	-1.6		-1.3	-2.6		-0.9		
			0/15	13.5		15	-4.2		-3.4	-6.8		-2.4		
		HCF Types	0/5	2.5		5	-1.53		-1.36	-3.2		-1.1		
			0/5	4.6		5	-0.52		-0.44	-1		-0.36		
			0/10	9.5		10	-1.3		-1.1	-2.6		-0.9		
			0/15	13.5		15	-3.6		-3.0	-6.8		-2.4		
I <sub>OL</sub>	Output Sink Current	HCC Types	0/5	0.4		5	0.64		0.51	1		0.36	mA	
			0/10	0.5		10	1.6		1.3	2.6		0.9		
			0/15	1.5		15	4.2		3.4	6.8		2.4		
		HCF Types	0/5	0.4		5	0.52		0.44	1		0.36		
			0/10	0.5		10	1.3		1.1	2.6		0.9		
			0/15	1.5		15	3.6		3.0	6.8		2.4		
I <sub>IH</sub> , I <sub>IL</sub>	Input Leakage Current	0/18	Any Input	18			$\pm 0.1$		$\pm 10^{-5}$	$\pm 0.1$		$\pm 1$	$\mu$ A	
		0/15		15		$\pm 0.3$		$\pm 10^{-5}$	$\pm 0.3$		$\pm 1$	$\mu$ A		
C <sub>I</sub>	Input Capacitance		Any Input						5	7.5			pF	

\* T<sub>LOW</sub> = -55 °C for HCC device; -40 °C for HCF device.

\* T<sub>HIGH</sub> = +125 °C for HCC device; +85 °C for HCF device.

The Noise Margin for both "1" and "0" level is: 1V min. with V<sub>DD</sub> = 5V, 2V min. with V<sub>DD</sub> = 10V, 2.5V min. with V<sub>DD</sub> = 15V

**DYNAMIC ELECTRICAL CHARACTERISTICS** ( $T_{amb} = 25\text{ }^{\circ}\text{C}$ ,  $C_L = 50\text{ pF}$ ,  $R_L = 200\text{ K}\Omega$ , typical temperature coefficient for all  $V_{DD}$  values is  $03\text{ } \%/^{\circ}\text{C}$ , all input rise and fall times =  $20\text{ ns}$ )

Symbol	Parameter	Test Conditions	Value			Unit	
			$V_{DD}$ (V)	Min.	Typ.		Max.
$t_{PLH}$ $t_{PHL}$	Propagation Delay Time ( $\phi$ to Q4 out)		5		370	740	ns
			10		150	300	
			15		100	200	
$t_{PLH}$ $t_{PHL}$	Propagation Delay Time ( $Q_n$ to $Q_{n+1}$ )		5		100	200	ns
			10		50	100	
			15		40	80	
$t_{TLH}$ $t_{THL}$	Transition Time		5		100	200	ns
			10		50	100	
			15		40	80	
$t_w$	Input Pulse Width	$f = 100\text{ KHz}$	5		50	100	ns
			10		20	40	
			15		15	30	
$t_r, t_f$	Input Pulse Rise and Fall Time		5	Unlimited			$\mu\text{s}$
			10				
			15				
$f_{max}$	Maximum Clock Input Frequency		5	3.5	7		MHz
			10	8	16		
			15	12	24		
<b>RESET OPERATION</b>							
$t_{PHL}$	Propagation Delay Time		5		180	360	ns
			10		80	160	
			15		50	100	
$t_w$	Reset Pulse Width		5		60	120	ns
			10		30	60	
			15		20	40	
<b>RC OPERATION</b>							
	Variation of Frequency (Unit-to-Unit)	$C_X = 200\text{ pF}$ $R_S = 560\text{ K}\Omega$ $R_X = 50\text{ K}\Omega$	5	18	21.5	25	KHz
			10	20	23	26	
			15	21.1	24	27	
	Variation of Frequency With Voltage Change (Same Unit)	$C_X = 200\text{ pF}$ $R_S = 560\text{ K}\Omega$ $R_X = 50\text{ K}\Omega$	5 to 10			2	KHz
			10 to 15			1	
$R_X$			$C_X = 10\text{ }\mu\text{F}$	5		20	$\text{M}\Omega$
			$C_X = 50\text{ }\mu\text{F}$	10		20	
			$C_X = 10\text{ }\mu\text{F}$	15		10	
$C_X$			$R_X = 500\text{ K}\Omega$	5		1000	mF
			$R_X = 300\text{ K}\Omega$	10		50	
			$R_X = 300\text{ K}\Omega$	15		50	
	Maximum Oscillator Frequency *	$R_X = 5\text{ K}\Omega$ $C_X = 15\text{ pF}$	10	530	650	810	pF
			15	690	800	94	

\* RC oscillator applications are not recommended at supply voltages below 7V for  $R_X = 50\text{ K}\Omega$

Typical Output Low (sink) Current Characteristics

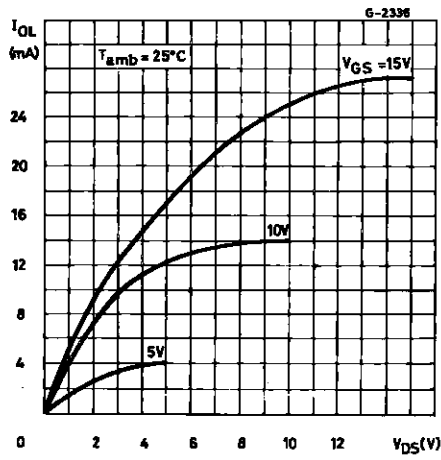

Minimum Output Low (sink) Current Characteristics

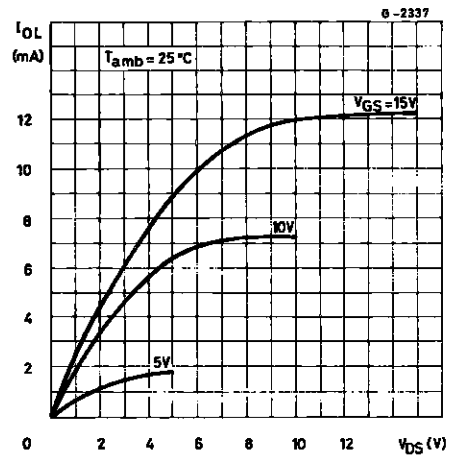

Typical Output High (source) Current Characteristics

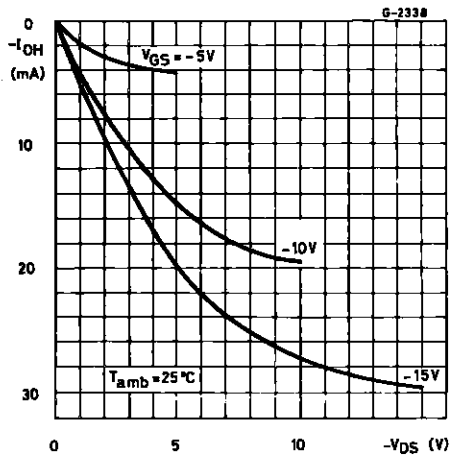

Minimum Output High (source) Current Characteristics

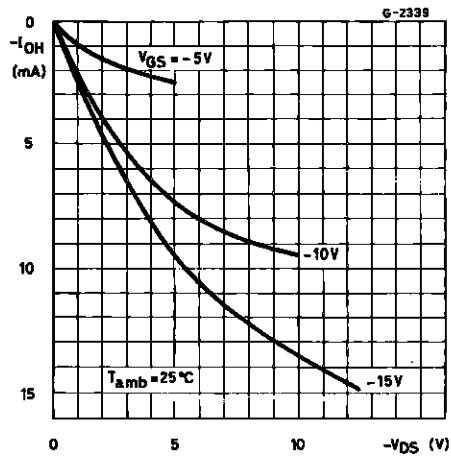

DETAIL OF TYPICAL FILP-FLOP STAGE

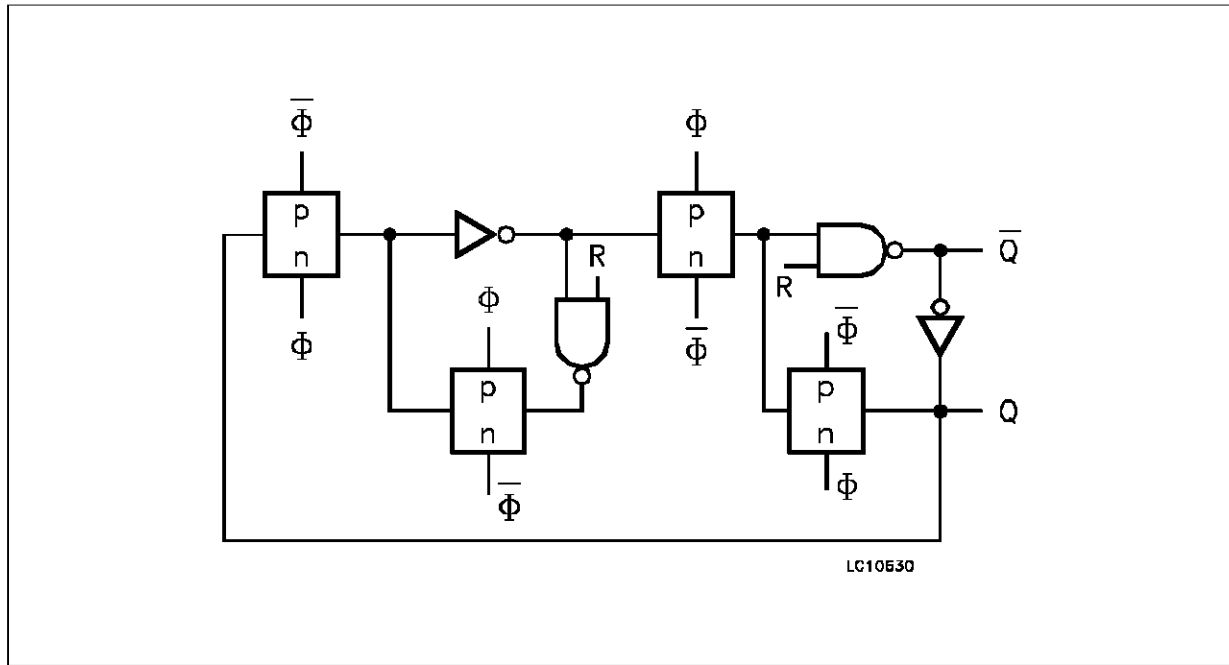

TYPICAL RC OSILLATOR CIRCUIT

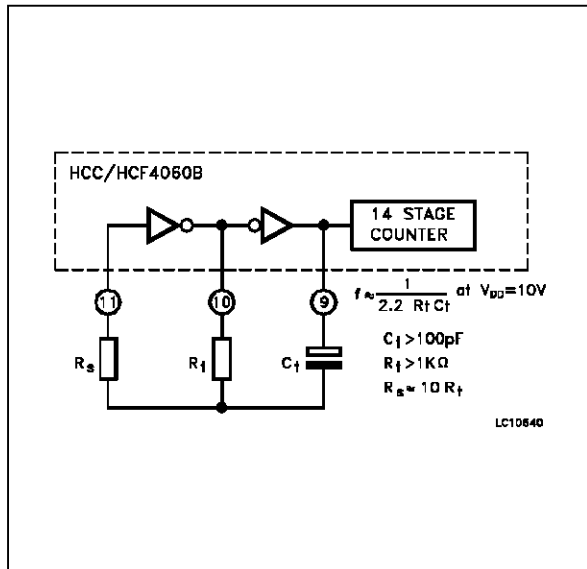

TYPICAL CRYSTAL OSCILLATOR CIRCUIT

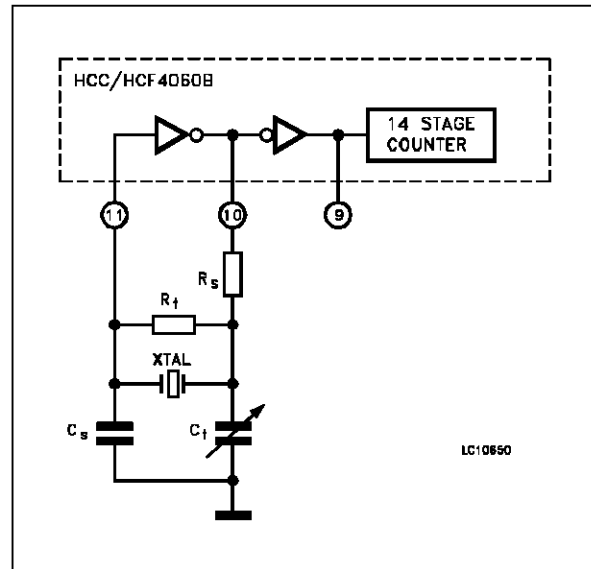

TEST CIRCUITS

Quiescent Device Current

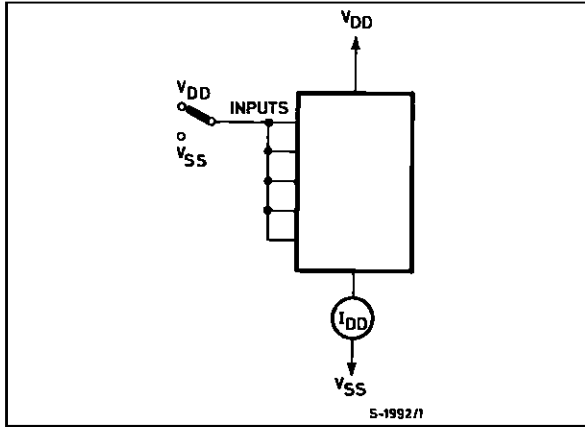

Noise Immunity.

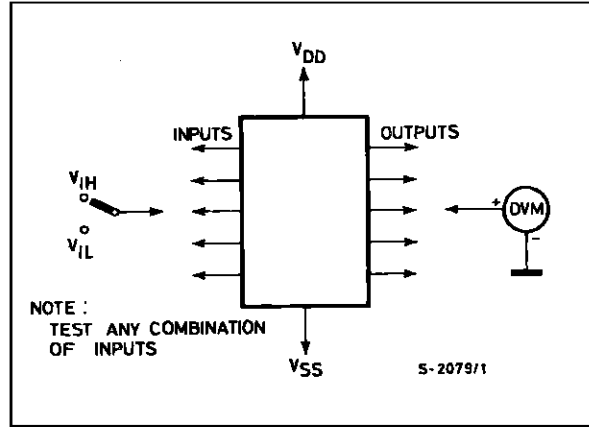

Input Leakage Current.

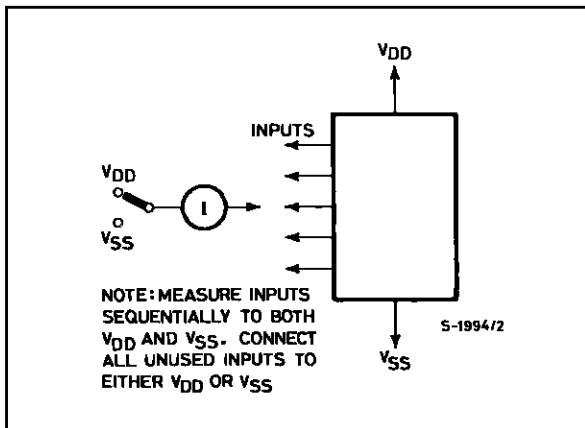

## Plastic DIP16 (0.25) MECHANICAL DATA

DIM.	mm			inch		
	MIN.	TYP.	MAX.	MIN.	TYP.	MAX.
a1	0.51			0.020		
B	0.77		1.65	0.030		0.065
b		0.5			0.020	
b1		0.25			0.010	
D			20			0.787
E		8.5			0.335	
e		2.54			0.100	
e3		17.78			0.700	
F			7.1			0.280
I			5.1			0.201
L		3.3			0.130	
Z			1.27			0.050

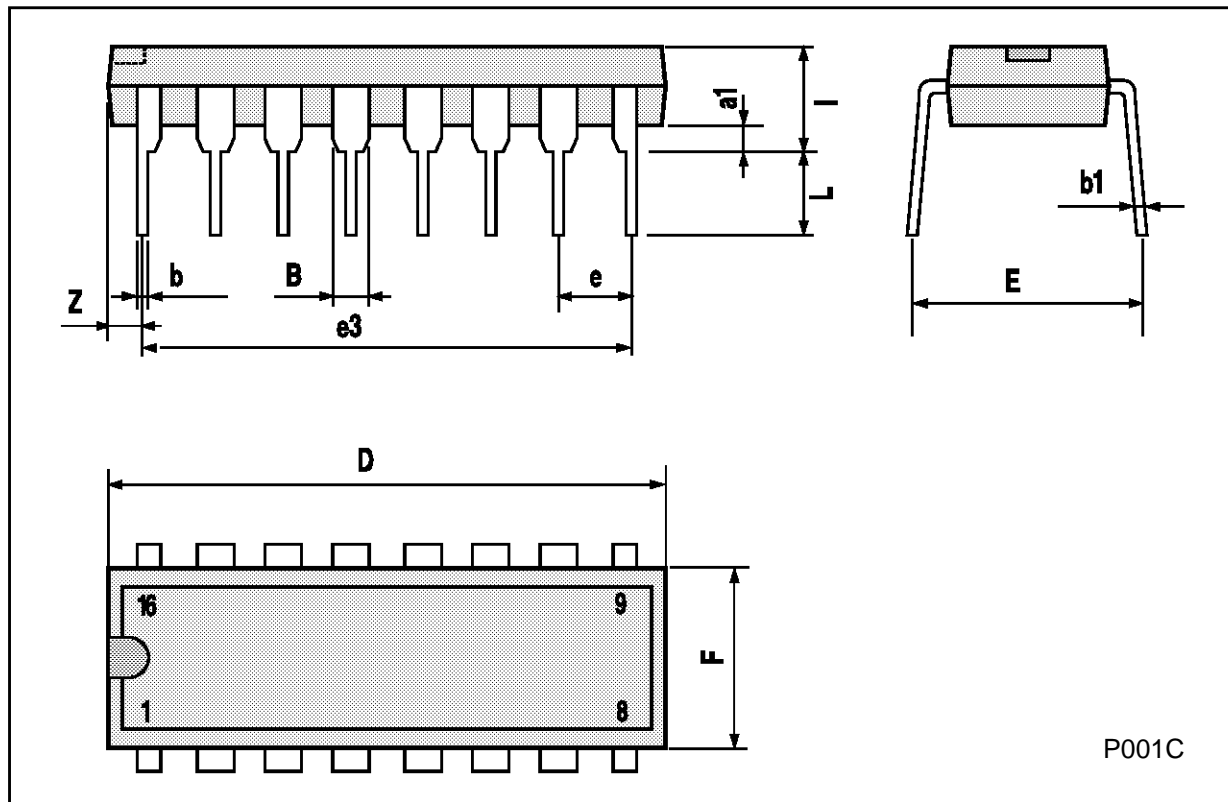

P001C

Ceramic DIP16/1 MECHANICAL DATA

DIM.	mm			inch		
	MIN.	TYP.	MAX.	MIN.	TYP.	MAX.
A			20			0.787
B			7			0.276
D		3.3			0.130	
E	0.38			0.015		
e3		17.78			0.700	
F	2.29		2.79	0.090		0.110
G	0.4		0.55	0.016		0.022
H	1.17		1.52	0.046		0.060
L	0.22		0.31	0.009		0.012
M	0.51		1.27	0.020		0.050
N			10.3			0.406
P	7.8		8.05	0.307		0.317
Q			5.08			0.200

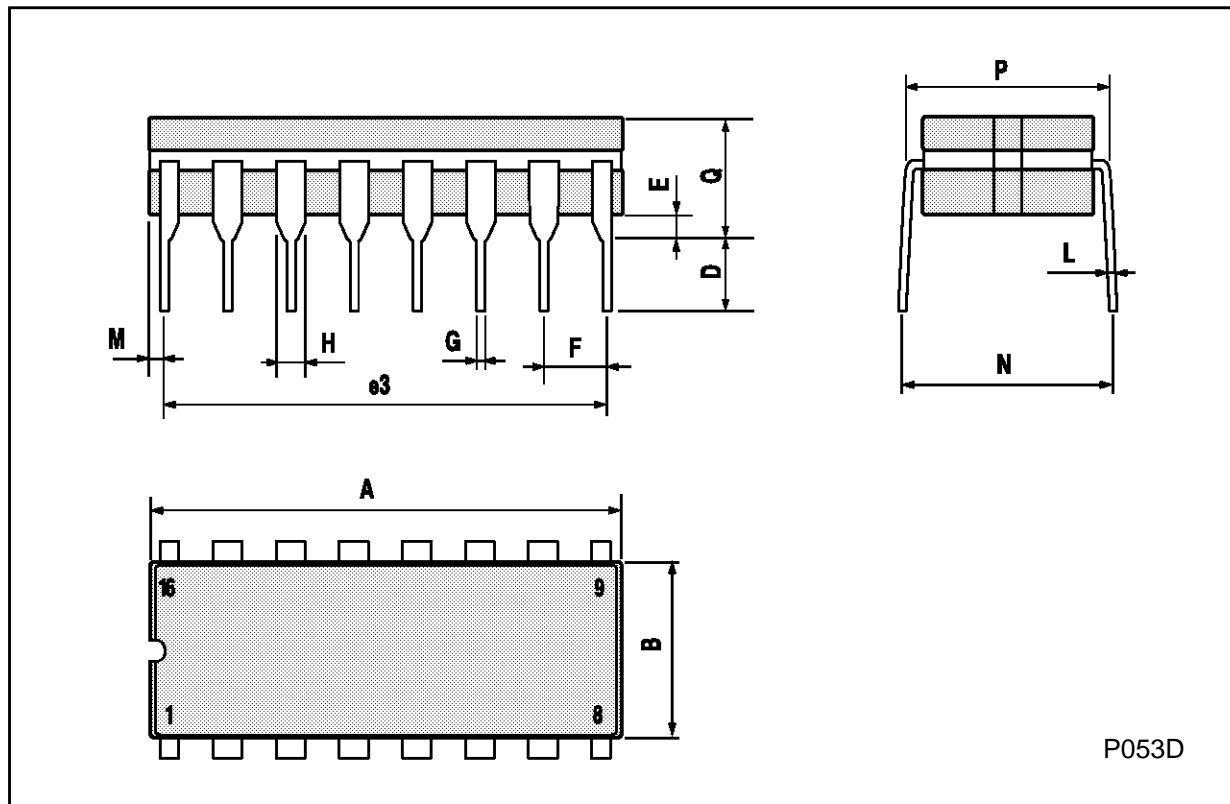

**SO16 (Narrow) MECHANICAL DATA**

DIM.	mm			inch		
	MIN.	TYP.	MAX.	MIN.	TYP.	MAX.
A			1.75			0.068
a1	0.1		0.2	0.004		0.007
a2			1.65			0.064
b	0.35		0.46	0.013		0.018
b1	0.19		0.25	0.007		0.010
C		0.5			0.019	
c1	45° (typ.)					
D	9.8		10	0.385		0.393
E	5.8		6.2	0.228		0.244
e		1.27			0.050	
e3		8.89			0.350	
F	3.8		4.0	0.149		0.157
G	4.6		5.3	0.181		0.208
L	0.5		1.27	0.019		0.050
M			0.62			0.024
S	8° (max.)					

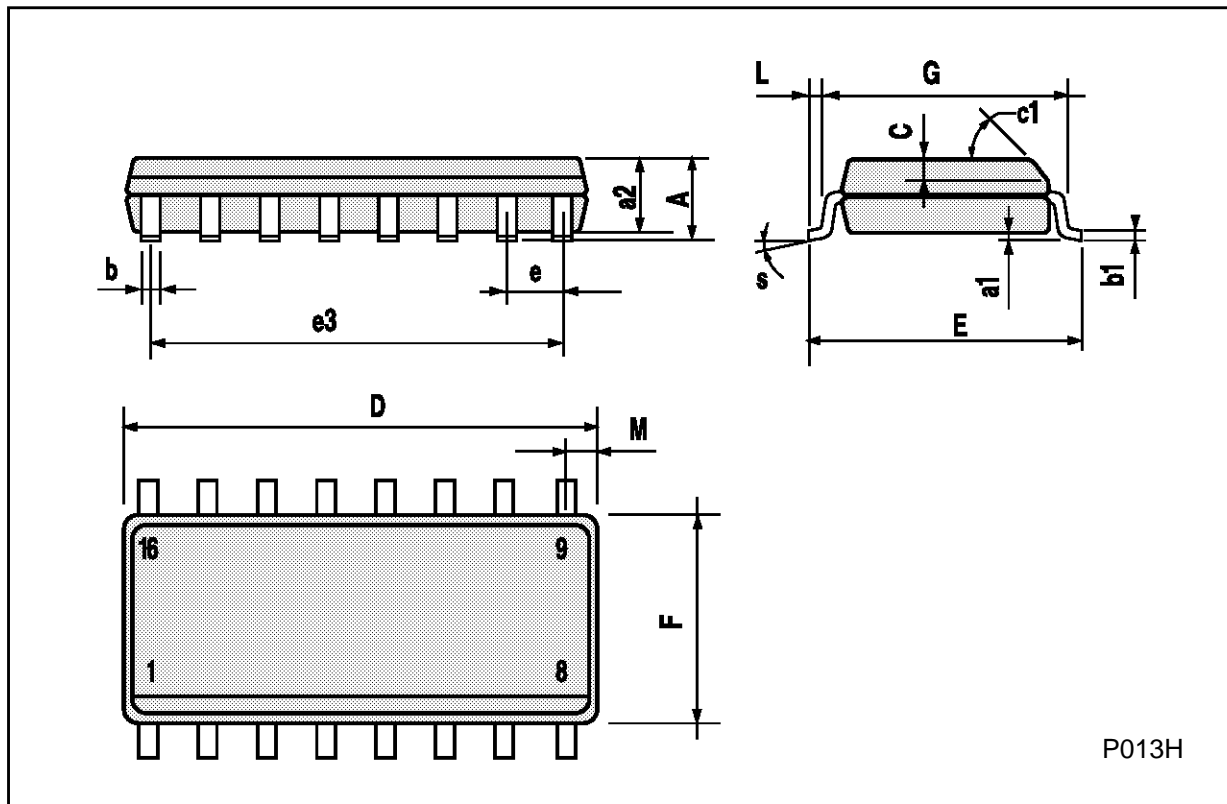

P013H

**PLCC20 MECHANICAL DATA**

DIM.	mm			inch		
	MIN.	TYP.	MAX.	MIN.	TYP.	MAX.
A	9.78		10.03	0.385		0.395
B	8.89		9.04	0.350		0.356
D	4.2		4.57	0.165		0.180
d1		2.54			0.100	
d2		0.56			0.022	
E	7.37		8.38	0.290		0.330
e		1.27			0.050	
e3		5.08			0.200	
F		0.38			0.015	
G			0.101			0.004
M		1.27			0.050	
M1		1.14			0.045	



Information furnished is believed to be accurate and reliable. However, SGS-THOMSON Microelectronics assumes no responsibility for the consequences of use of such information nor for any infringement of patents or other rights of third parties which may result from its use. No license is granted by implication or otherwise under any patent or patent rights of SGS-THOMSON Microelectronics. Specifications mentioned in this publication are subject to change without notice. This publication supersedes and replaces all information previously supplied. SGS-THOMSON Microelectronics products are not authorized for use as critical components in life support devices or systems without express written approval of SGS-THOMSON Microelectronics.

© 1994 SGS-THOMSON Microelectronics - All Rights Reserved

SGS-THOMSON Microelectronics GROUP OF COMPANIES

Australia - Brazil - France - Germany - Hong Kong - Italy - Japan - Korea - Malaysia - Malta - Morocco - The Netherlands -  
Singapore - Spain - Sweden - Switzerland - Taiwan - Thailand - United Kingdom - U.S.A