

QUAD 2-INPUT NAND SCHMIDT TRIGGERS

- SCHMITT-TRIGGER ACTION ON EACH INPUT WITH NO EXTERNAL COMPONENTS
- HYSTERESIS VOLTAGE TYPICALLY 0.9V AT $V_{DD} = 5V$ AND 2.3V AT $V_{DD} = 10V$
- NOISE IMMUNITY GREATER THAN 50% OF V_{DD} (typ.)
- NO LIMIT ON INPUT RISE AND FALL TIMES
- STANDARDIZED SYMMETRICAL OUTPUT CHARACTERISTICS
- QUIESCENT CURRENT SPECIFIED TO 20V FOR HCC DEVICE
- 5V, 10V, AND 15V PARAMETRIC RATINGS
- INPUT CURRENT OF 100nA AT 18V AND 25°C FOR HCC DEVICE
- 100% TESTED FOR QUIESCENT CURRENT
- MEETS ALL REQUIREMENTS OF JEDEC TENTATIVE STANDARD N°. 13A, "STANDARD SPECIFICATIONS FOR DESCRIPTION OF "B" SERIES CMOS DEVICES"

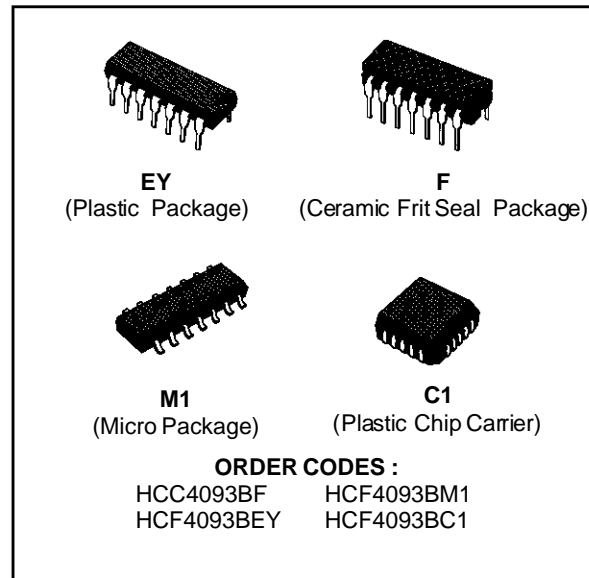

DESCRIPTION

The **HCC4093B** (extended temperature range) and **HCF4093B** (intermediate temperature range) are available in 14-lead dual in-line plastic or ceramic package and plastic micropackage. The **HCC/HCF4093B** consists of four Schmitt-trigger circuits. Each circuit functions as a two-input NAND gate with Schmitt-trigger action on both inputs. The gate switches at different points for positive and negative-going signals.

The difference between the positive voltage (V_P) and the negative voltage (V_N) is defined as hysteresis voltage (V_H) (see fig. 1).

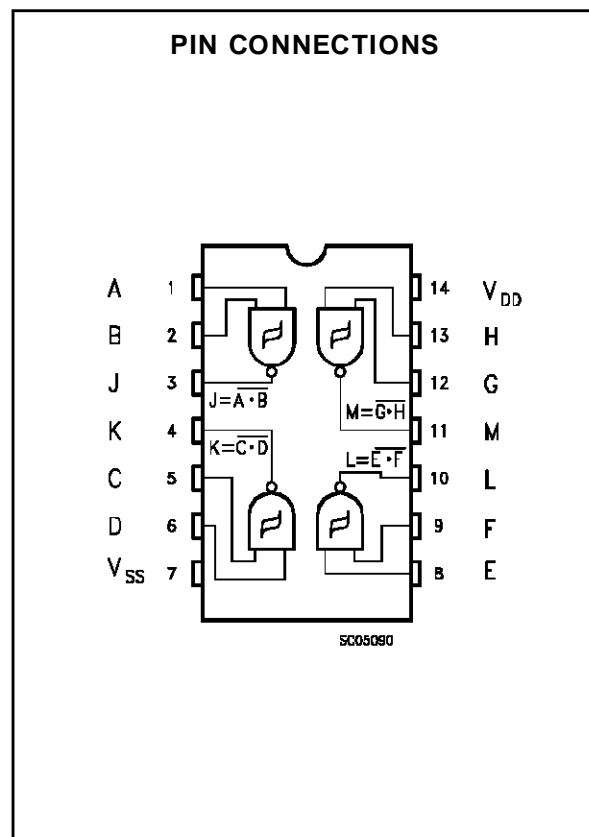

FUNCTIONAL DIAGRAM

1 of 4 Schmitt triggers

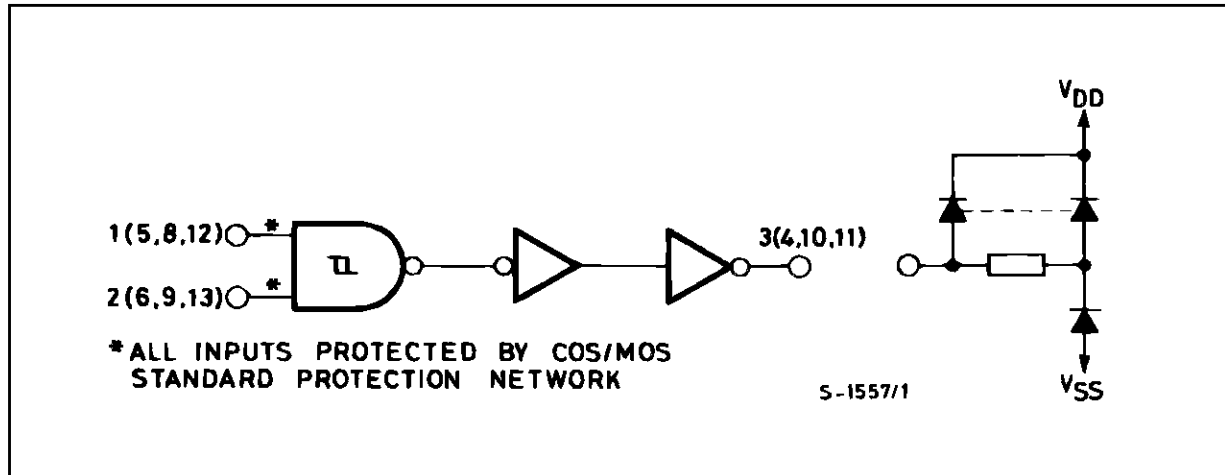

ABSOLUTE MAXIMUM RATINGS

Symbol	Parameter	Value	Unit
V_{DD}^*	Supply Voltage : HCC Types HCF Types	- 0.5 to + 20 - 0.5 to + 18	V V
V_I	Input Voltage	- 0.5 to $V_{DD} + 0.5$	V
I_I	DC Input Current (any one input)	± 10	mA
P_{tot}	Total Power Dissipation (per package) Dissipation per Output Transistor for T_{op} = Full Package-temperature Range	200 100	mW mW
T_{op}	Operating Temperature : HCC Types HCF Types	- 55 to + 125 - 40 to + 85	$^{\circ}C$ $^{\circ}C$
T_{stg}	Storage Temperature	- 65 to + 150	$^{\circ}C$

Stresses above those listed under "Absolute Maximum Ratings "may cause permanent damage to the device. This is a stress rating only and functional operation of the device at these or any other conditions above those indicated in the operational sections of this specification is not implied. Exposure to absolute maximum rating conditions for external periods may affect device reliability.

* All voltage values are referred to V_{SS} pin voltage.

RECOMMENDED OPERATING CONDITIONS

Symbol	Parameter	Value	Unit
V_{DD}	Supply Voltage : HCC Types HCF Types	3 to 18 3 to 15	V V
V_I	Input Voltage	0 to V_{DD}	V
T_{op}	Operating Temperature : HCC Types HCF Types	- 55 to + 125 - 40 to + 85	$^{\circ}C$ $^{\circ}C$

STATIC ELECTRICAL CHARACTERISTICS (over recommended operating conditions)

Symbol	Parameter		Test Conditions				Value						Unit	
			V _I (V)	V _O (V)	I _O (μ A)	V _{DD} (V)	T _{Low} *		25°C			T _{High} *		
							Min.	Max.	Min.	Typ.	Max.	Min.		Max.
I _L	Quiescent Current	HCC Types	0/ 5			5		1		0.02	1		30	μ A
			0/10			10		2		0.02	2		60	
			0/15			15		4		0.02	4		120	
		0/20			20		20		0.04	20		600		
		HCF Types	0/ 5			5		4		0.02	4		30	
			0/10			10		8		0.02	8		60	
0/15				15		16		0.02	16		120			
V _P	Positive Trigger Threshold Voltage		a			5	2.2	3.6	2.2	2.9	3.6	2.2	3.6	V
			a			10	4.6	7.1	4.6	5.9	7.1	4.6	7.1	
			a			15	6.8	10.8	6.8	8.8	10.8	6.8	10.8	
			b			5	2.6	4	2.6	3.3	4	2.6	4	
			b			10	5.6	8.2	5.6	7	8.2	5.6	8.2	
			b			15	6.3	12.7	6.3	9.4	12.7	6.3	12.7	
V _N	Negative Trigger Threshold Voltage		a			5	0.9	2.8	0.9	1.9	2.8	0.9	2.8	V
			a			10	2.5	5.2	2.5	3.9	5.2	2.5	5.2	
			a			15	4	7.4	4	5.8	7.4	4	7.4	
			b			5	1.4	3.2	1.4	2.3	3.2	1.4	3.2	
			b			10	3.4	6.6	3.4	5.1	6.6	3.4	6.6	
			b			15	4.8	9.6	4.8	7.3	9.6	4.8	9.6	
V _H	Hysteresis Voltage		a			5	0.3	1.6	0.3	0.9	1.6	0.3	1.6	V
			a			10	1.2	3.4	1.2	2.3	3.4	1.2	3.4	
			a			15	1.6	5	1.6	3.5	5	1.6	5	
			b			5	0.3	1.6	0.3	0.9	1.6	0.3	1.6	
			b			10	1.2	3.4	1.2	2.3	3.4	1.2	3.4	
			b			15	1.6	5	1.6	3.5	5	1.6	5	
V _{OH}	Output High Voltage		0/ 5		< 1	5	4.95		4.95			4.95	V	
			0/10		< 1	10	9.95		9.95			9.95		
			0/15		< 1	15	14.95		14.95			14.95		
V _{OL}	Output Low Voltage		5/0		< 1	5		0.05			0.05	0.05	V	
			10/0		< 1	10		0.05			0.05	0.05		
			15/0		< 1	15		0.05			0.05	0.05		
I _{OH}	Output Drive Current	HCC Types	0/ 5	2.5		5	- 2		- 1.6	- 3.2		- 1.15	mA	
			0/ 5	4.6		5	- 0.64		- 0.51	- 1		- 0.36		
			0/10	9.5		10	- 1.6		- 1.3	- 2.6		- 0.9		
			0/15	13.5		15	- 4.2		- 3.4	- 6.8		- 2.4		
		HCF Types	0/ 5	2.5		5	- 1.53		- 1.36	- 3.2		- 1.1		
			0/ 5	4.6		5	- 0.52		- 0.44	- 1		- 0.36		
			0/10	9.5		10	- 1.3		- 1.1	- 2.6		- 0.9		
			0/15	13.5		15	- 3.6		- 3.0	- 6.8		- 2.4		

a : input on terminals 1, 5, 8, 12 or 2, 6, 9, 13 ; other inputs to V_{DD}.

b : input on terminals 1 and 2, 5 and 6, 8 and 9, or 12 and 13 ; other inputs to V_{DD}.

* T_{Low} = -55°C for HCC device : -40°C for HCF device.

* T_{High} = +125°C for HCC device : +85°C for HCF device.

STATIC ELECTRICAL CHARACTERISTICS (continued)

Symbol	Parameter	Test Conditions				Value						Unit	
		V _I (V)	V _O (V)	I _O (μA)	V _{DD} (V)	T _{Low} *		25°C			T _{High} *		
						Min.	Max.	Min.	Typ.	Max.	Min.		Max.
I _{OL}	Output Sink Current	0/ 5	0.4		5	0.64		0.51	1		0.36	mA	
		0/10	0.5		10	1.6		1.3	2.6		0.9		
		0/15	1.5		15	4.2		3.4	6.8		2.4		
		0/ 5	0.4		5	0.52		0.44	1		0.36		
		0/10	0.5		10	1.3		1.1	2.6		0.9		
		0/15	1.5		15	3.6		3.0	6.8		2.4		
I _{IH} , I _{IL}	Input Leakage Current	HCC Types	0/18	Any Input	18		± 0.1		± 10 ⁻⁵	± 0.1		± 1	μA
		HCF Types	0/15		15		± 0.3		± 10 ⁻⁵	± 0.3		± 1	
C _I	Input Capacitance			Any Input				5	7.5			pF	

DYNAMIC ELECTRICAL CHARACTERISTICS (T_{amb} = 25°C, C_L = 50pF, R_L = 200kΩ, typical temperature coefficient for all V_{DD} = 0.3%/°C values , all input rise and fall time = 20ns)

Symbol	Parameter	Test Conditions		Value			Unit
			V _{DD} (V)	Min.	Typ.	Max.	
t _{PLH} , t _{PHL}	Propagation Delay Time		5		190	380	ns
			10		90	180	
			15		65	130	
t _{TLH} , t _{THL}	Transition Time		5		100	200	ns
			10		50	100	
			15		40	80	

Figure1 : Hysteresis Definition, Characteristics and Test Setup.

(a) Definition of V_P, V_N and V_H

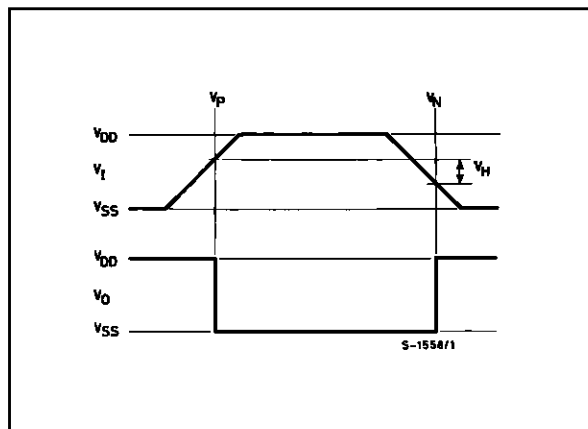

(b) Transfer characteristics of 1 of 4 gates

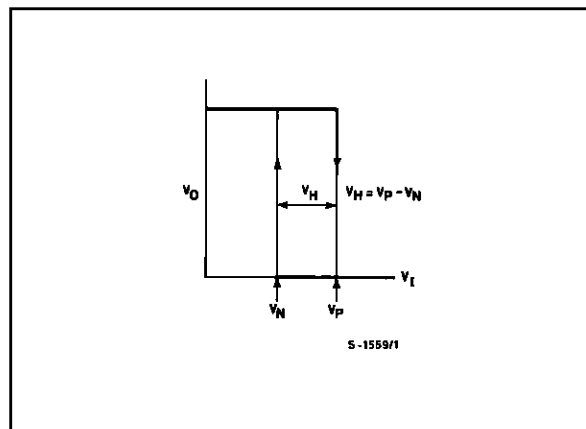

(c) Test setup

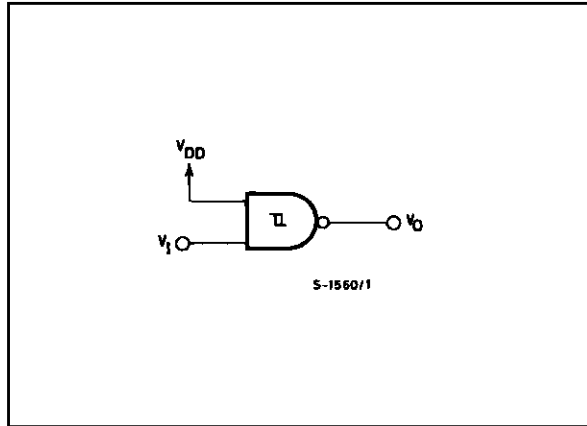

Figure 2 : Input and Output Characteristics.

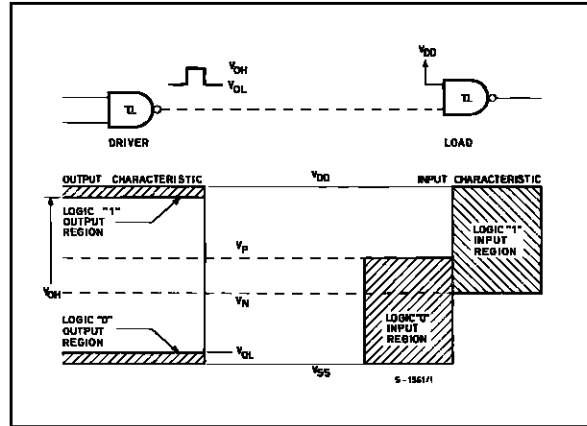

Figure 3 : Typical Current and Voltage Transfer Characteristics.

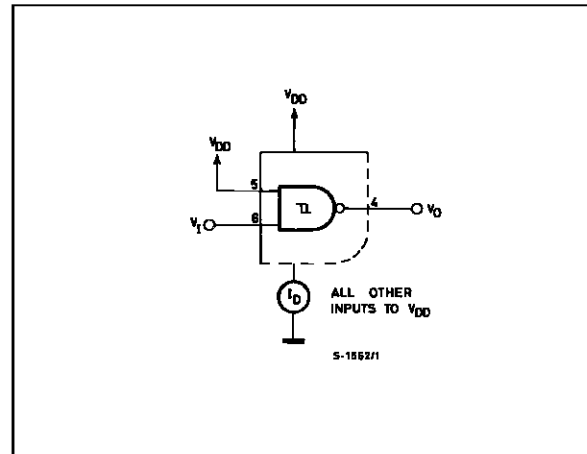
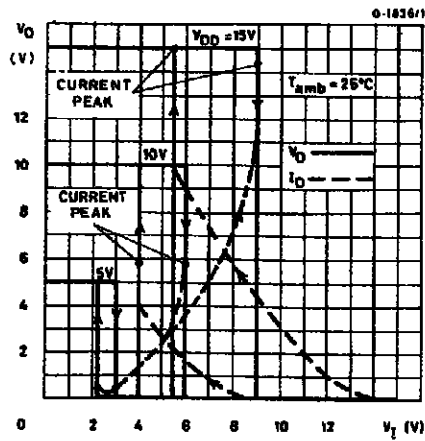

Figure 4 : Typical Voltage Transfer Characteristics as a Function of Temperature, and Test Circuit.

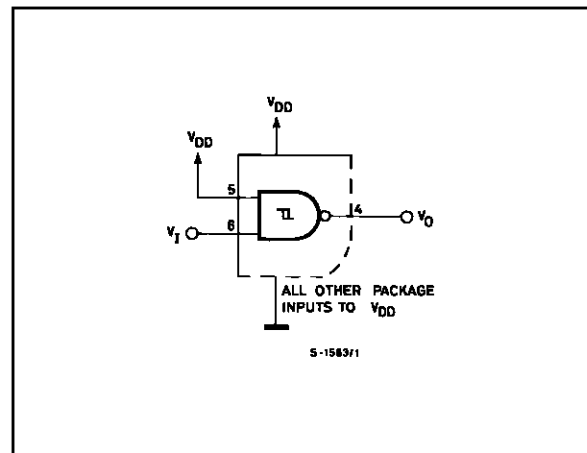
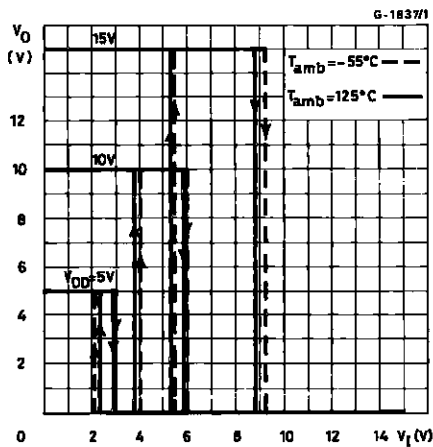

Figure 5 : Typical Output Low (sink) Current Characteristics.

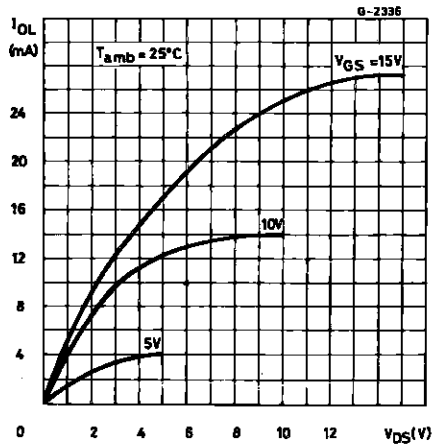

Figure 6 : Minimum Output Low (sink) Current Characteristics.

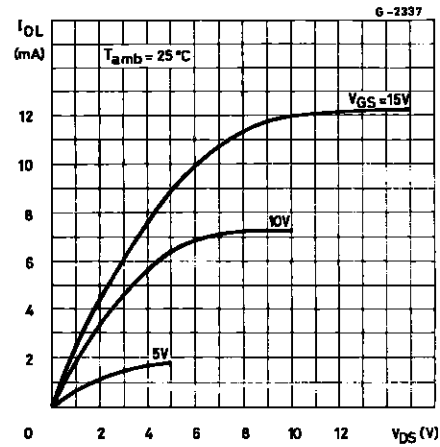

Figure 7 : Typical Output High (source) Current Characteristic.

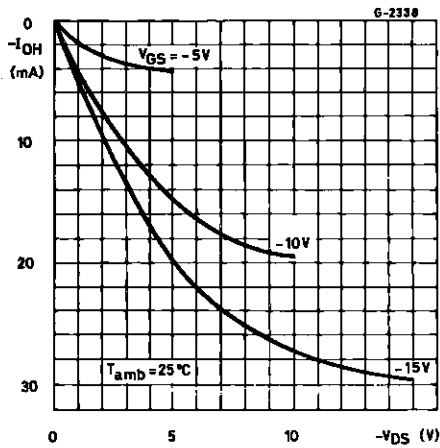

Figure 8 : Minimum Output High Current Characteristics.

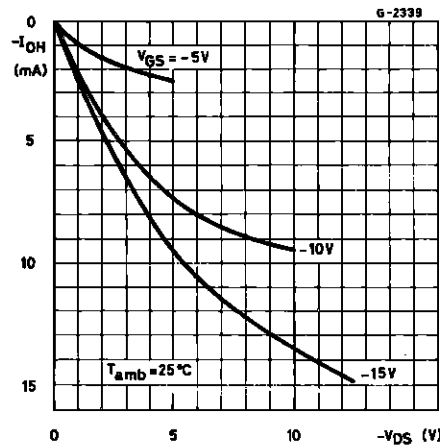

Figure 9 : Typical Propagation Delay Time vs. Supply Voltage.

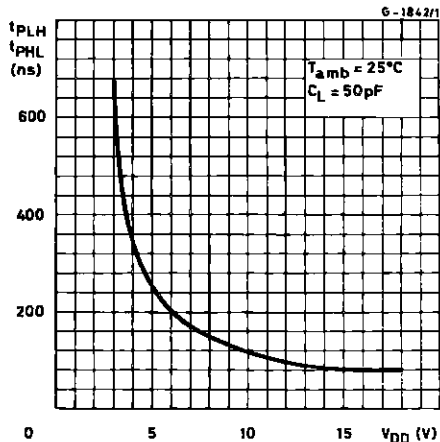

Figure 10 : Typical Transition Time vs. Load Capacitance.

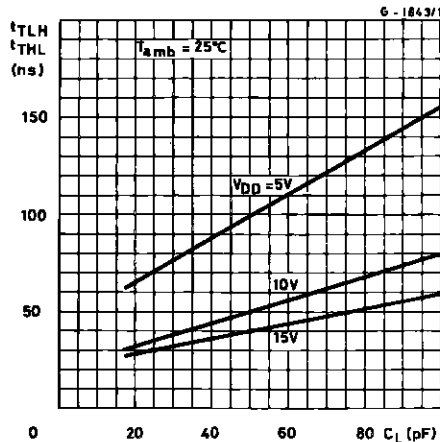

Figure 11 : Typical Trigger Threshold Voltage vs. V_{DD}

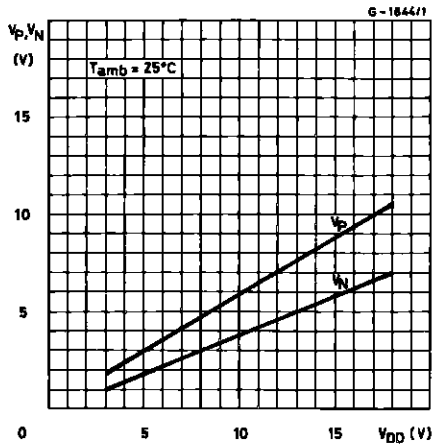

Figure 12 : Typical per cent Hysteresis vs. Supply Voltage.

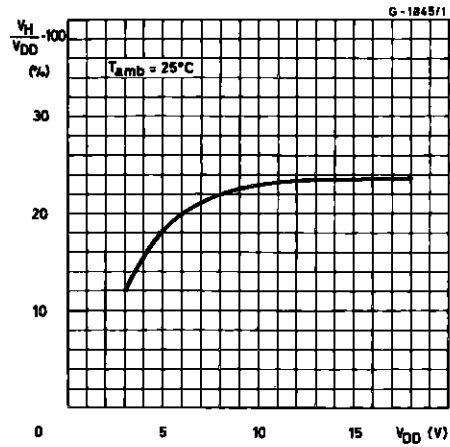

Figure 13 : Typical Dissipation Characteristics.

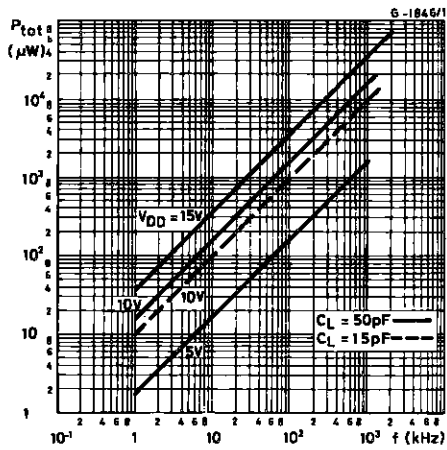
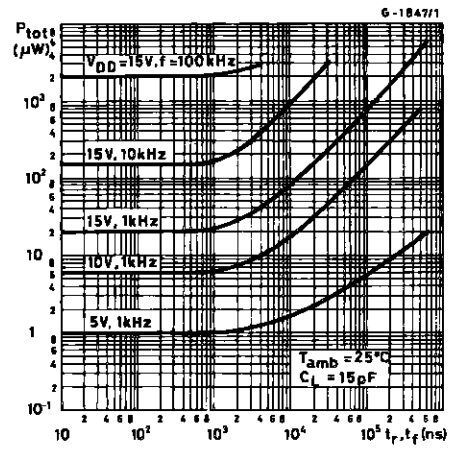

Figure 14 : Power Dissipation vs. Rise and Fall Times.



APPLICATIONS

Figure 15 : Wave Shaper.

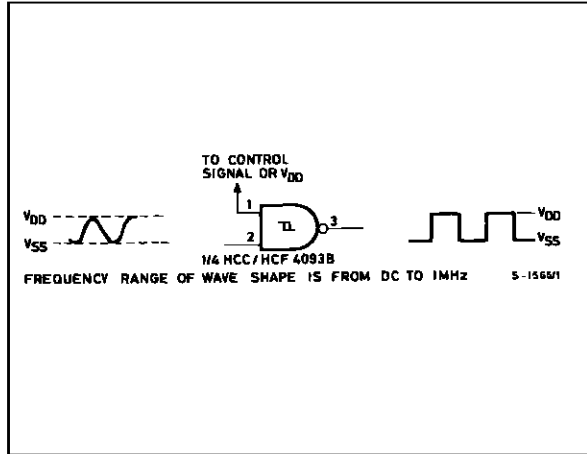

Figure 16 : Monostable Multivibrator.

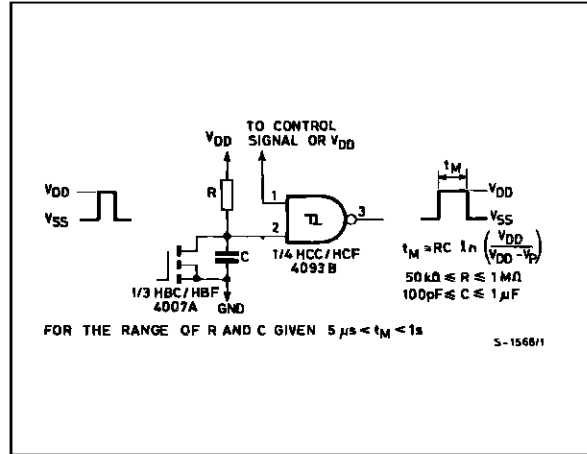
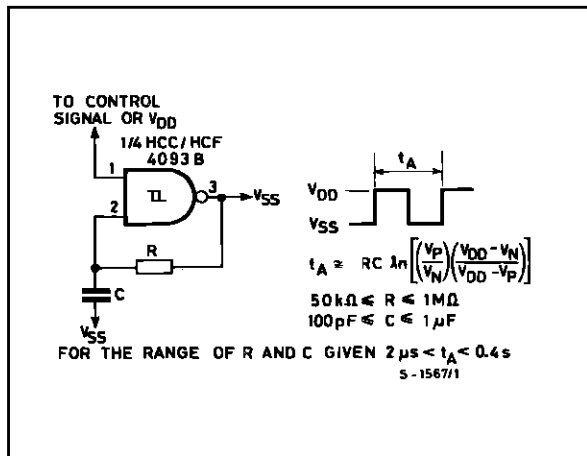

Figure 17 : Astable Multivibrator.



TEST CIRCUITS

Figure 18 : Quiescent Device Current.

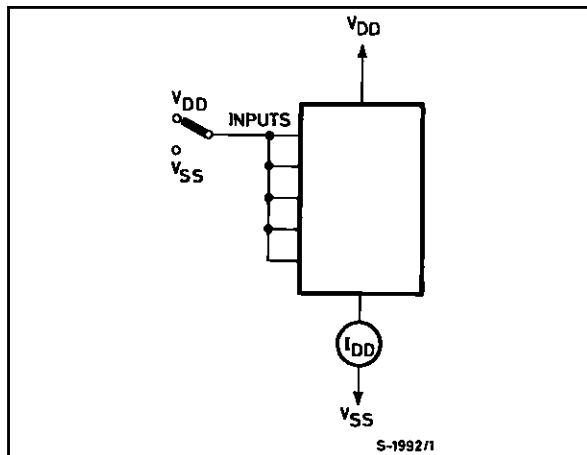
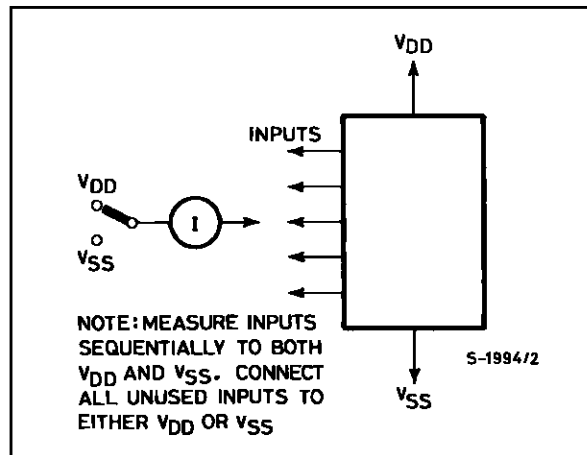
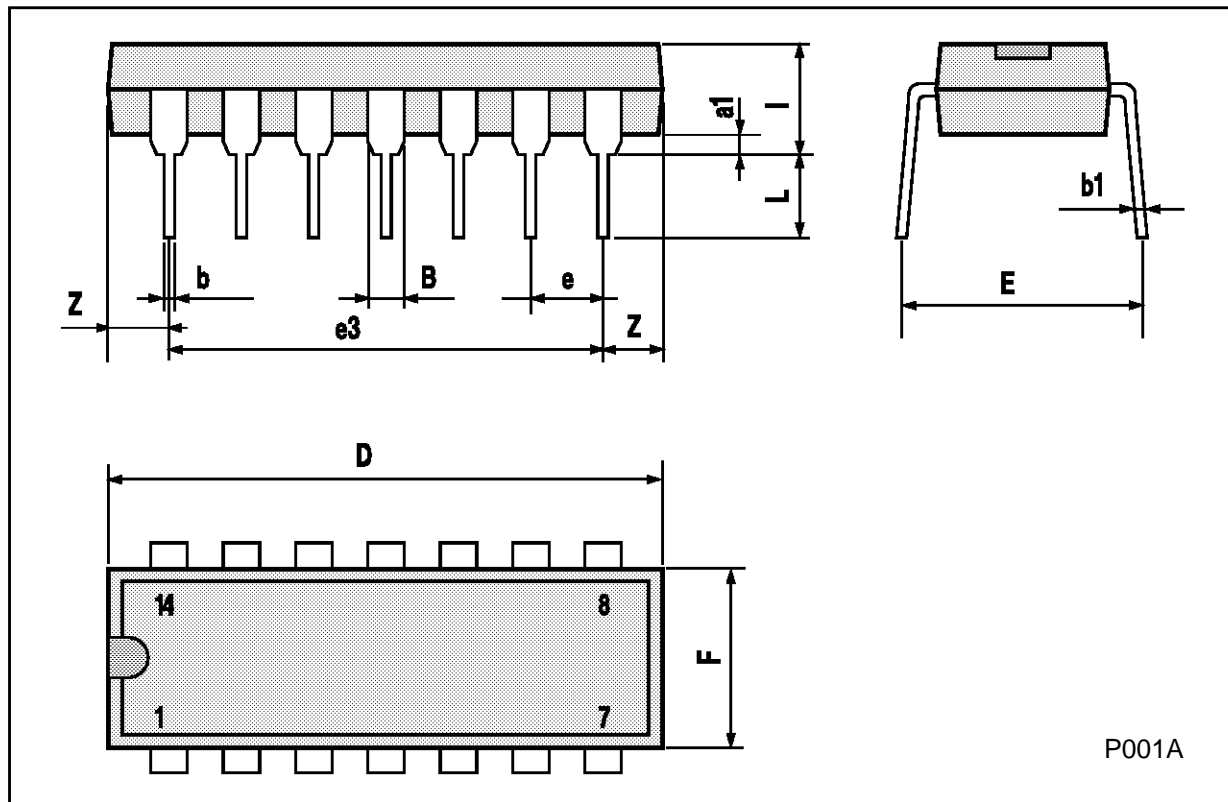

Figure 19 : Input Leakage Current.



Plastic DIP14 MECHANICAL DATA

DIM.	mm			inch		
	MIN.	TYP.	MAX.	MIN.	TYP.	MAX.
a1	0.51			0.020		
B	1.39		1.65	0.055		0.065
b		0.5			0.020	
b1		0.25			0.010	
D			20			0.787
E		8.5			0.335	
e		2.54			0.100	
e3		15.24			0.600	
F			7.1			0.280
I			5.1			0.201
L		3.3			0.130	
Z	1.27		2.54	0.050		0.100



Ceramic DIP14/1 MECHANICAL DATA

DIM.	mm			inch		
	MIN.	TYP.	MAX.	MIN.	TYP.	MAX.
A			20			0.787
B			7.0			0.276
D		3.3			0.130	
E	0.38			0.015		
e3		15.24			0.600	
F	2.29		2.79	0.090		0.110
G	0.4		0.55	0.016		0.022
H	1.17		1.52	0.046		0.060
L	0.22		0.31	0.009		0.012
M	1.52		2.54	0.060		0.100
N			10.3			0.406
P	7.8		8.05	0.307		0.317
Q			5.08			0.200

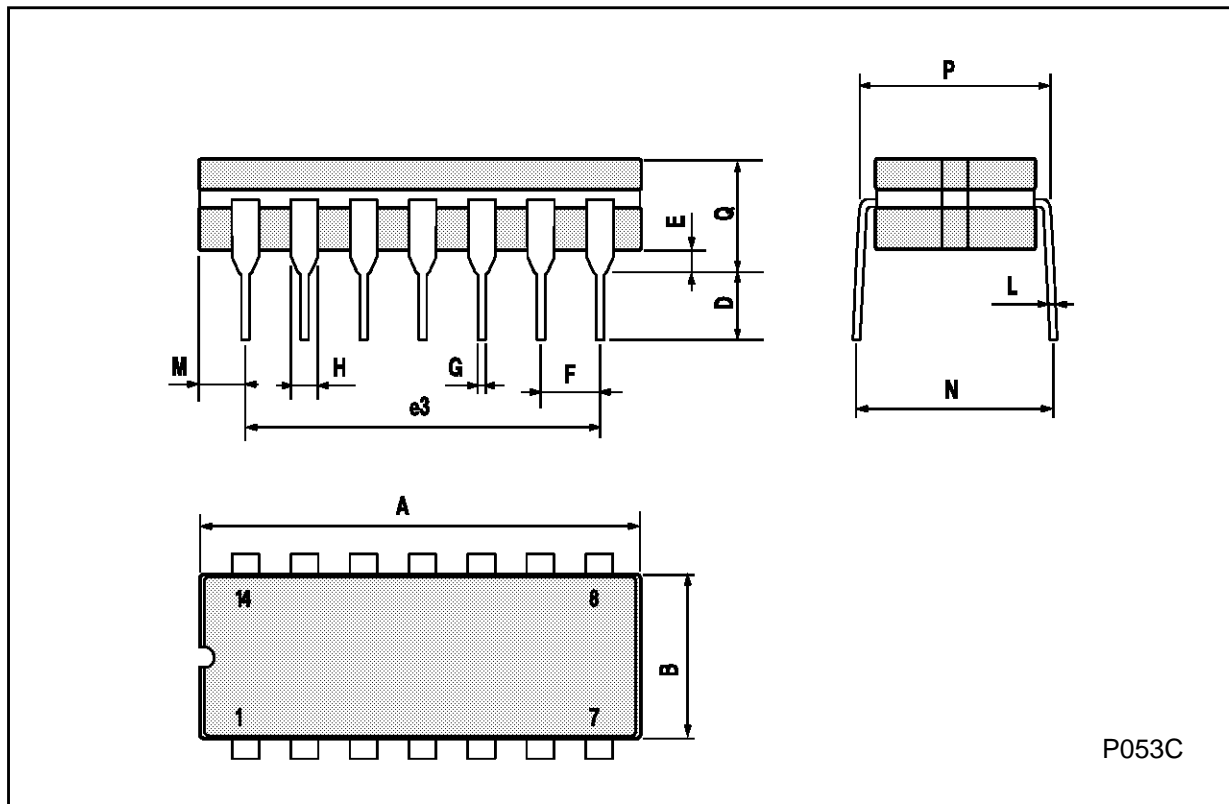

P053C

SO14 MECHANICAL DATA

DIM.	mm			inch		
	MIN.	TYP.	MAX.	MIN.	TYP.	MAX.
A			1.75			0.068
a1	0.1		0.2	0.003		0.007
a2			1.65			0.064
b	0.35		0.46	0.013		0.018
b1	0.19		0.25	0.007		0.010
C		0.5			0.019	
c1	45° (typ.)					
D	8.55		8.75	0.336		0.344
E	5.8		6.2	0.228		0.244
e		1.27			0.050	
e3		7.62			0.300	
F	3.8		4.0	0.149		0.157
G	4.6		5.3	0.181		0.208
L	0.5		1.27	0.019		0.050
M			0.68			0.026
S	8° (max.)					

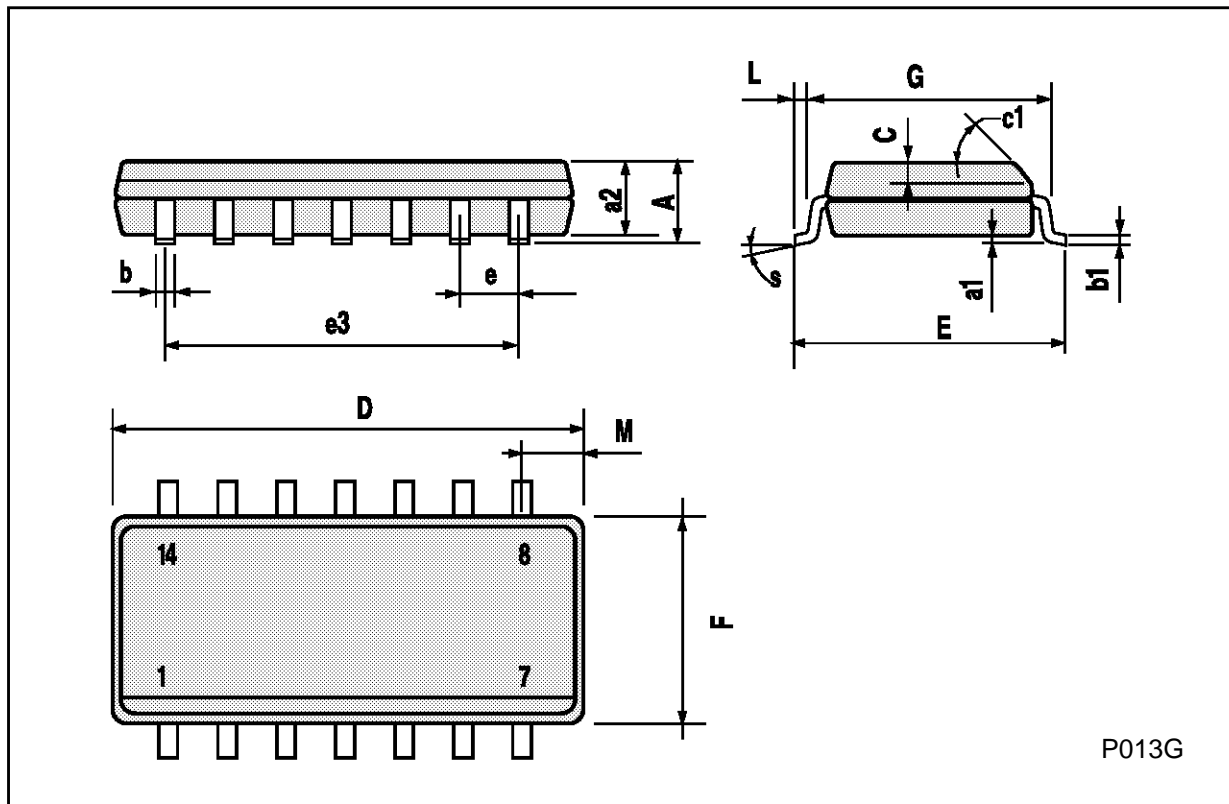

P013G

PLCC20 MECHANICAL DATA

DIM.	mm			inch		
	MIN.	TYP.	MAX.	MIN.	TYP.	MAX.
A	9.78		10.03	0.385		0.395
B	8.89		9.04	0.350		0.356
D	4.2		4.57	0.165		0.180
d1		2.54			0.100	
d2		0.56			0.022	
E	7.37		8.38	0.290		0.330
e		1.27			0.050	
e3		5.08			0.200	
F		0.38			0.015	
G			0.101			0.004
M		1.27			0.050	
M1		1.14			0.045	



Information furnished is believed to be accurate and reliable. However, SGS-THOMSON Microelectronics assumes no responsibility for the consequences of use of such information nor for any infringement of patents or other rights of third parties which may result from its use. No license is granted by implication or otherwise under any patent or patent rights of SGS-THOMSON Microelectronics. Specifications mentioned in this publication are subject to change without notice. This publication supersedes and replaces all information previously supplied. SGS-THOMSON Microelectronics products are not authorized for use as critical components in life support devices or systems without express written approval of SGS-THOMSON Microelectronics.

© 1994 SGS-THOMSON Microelectronics - All Rights Reserved

SGS-THOMSON Microelectronics GROUP OF COMPANIES

Australia - Brazil - France - Germany - Hong Kong - Italy - Japan - Korea - Malaysia - Malta - Morocco - The Netherlands -
Singapore - Spain - Sweden - Switzerland - Taiwan - Thailand - United Kingdom - U.S.A