

QUAD LOW-TO-HIGH VOLTAGE LEVEL SHIFTER

- INDEPENDENCE OF POWER SUPPLY SEQUENCE CONSIDERATIONS – V_{CC} CAN EXCEED V_{DD} , INPUT SIGNALS CAN EXCEED BOTH V_{CC} AND V_{DD}
- UP AND DOWN LEVEL-SHIFTING CAPABILITY
- THREE-STATE OUTPUTS WITH SEPARATE ENABLE CONTROLS
- STANDARDIZED SYMMETRICAL OUTPUT CHARACTERISTICS
- QUIESCENT CURRENT SPECIFIED AT 20V FOR HCC DEVICE
- 5V, 10V, AND 15V PARAMETRIC RATINGS
- INPUT CURRENT OF 100nA AT 18V AND 25°C FOR HCC DEVICE
- 100% TESTED FOR QUIESCENT CURRENT
- MEETS ALL REQUIREMENTS OF JEDEC TENTATIVE STANDARD N°. 13A, "STANDARD SPECIFICATIONS FOR DESCRIPTION OF "B" SERIES CMOS DEVICES"

controls produces a high-impedance state in the corresponding output.

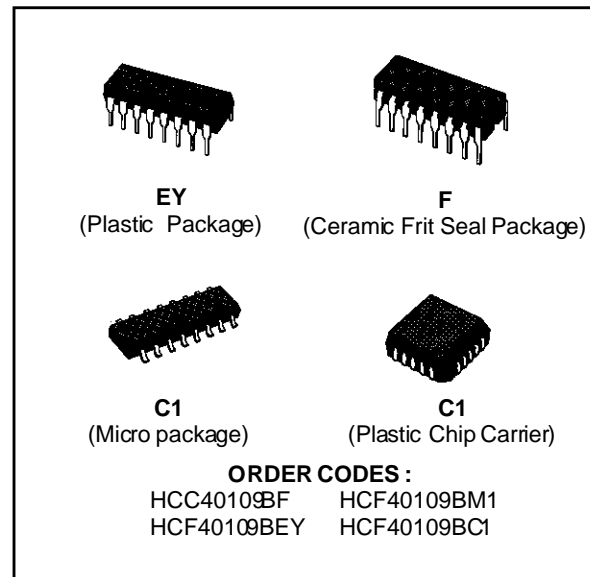

DESCRIPTION

The **HCC40109B** (extended temperature range) and **HCF40109B** (intermediate temperature range) are monolithic integrated circuits, available in 16-lead dual in-line plastic or ceramic package and plastic micropackage. The **HCC/HCF40109B** contains four low-to-high-voltage level-shifting circuits. Each circuit will shift a low-voltage digital-logic input signal (A, B, C, D) with logical 1 = V_{CC} and logical 0 = V_{SS} to a higher-voltage output signal (E, F, G, H) with logical 1 = V_{DD} and logical 0 = V_{SS} . The **HCC/HCF40109B**, unlike other low-to-high level-shifting circuits, does not require the presence of the high-voltage supply (V_{DD}) before the application of either the low-voltage supply (V_{CC}) or the input signals. There are no restrictions on the sequence of application of V_{DD} , V_{CC} , or the input signals. In addition, there are no restrictions on the relative magnitudes of the supply voltages or input signals within the device maximum ratings ; V_{CC} may exceed V_{DD} , and input signals may exceed V_{CC} , and V_{DD} . When operated in the mode $V_{CC} = V_{DD}$, the **HCC/HCF40109B**, will operate as a high-to-low level-shifter. The **HCC/HCF 40109B** also features individual three-state output capability. A low level on any of the separately enabled three-state output

PIN CONNECTIONS

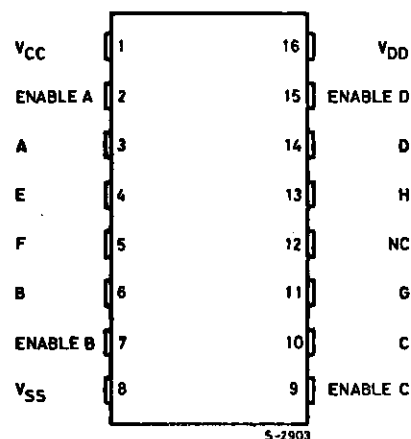

FUNCTIONAL DIAGRAM

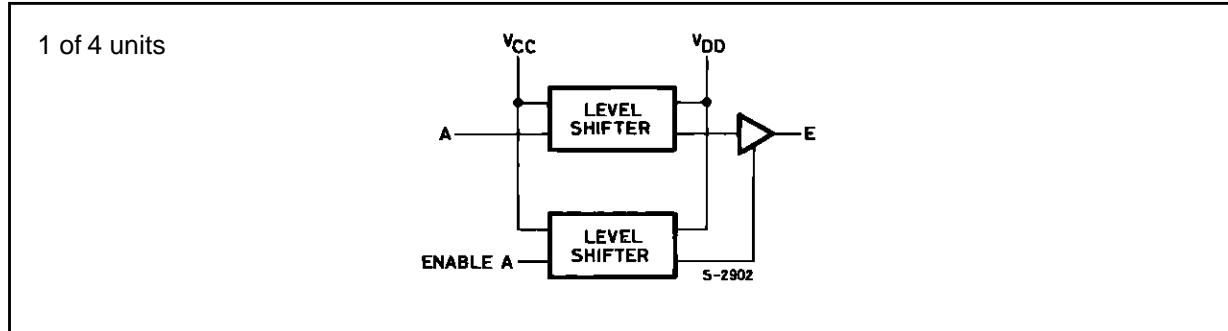

ABSOLUTE MAXIMUM RATINGS

Symbol	Parameter	Value	Unit
V_{DD}^*	Supply Voltage : HCC Types HCF Types	- 0.5 to + 20 - 0.5 to + 18	V
V_i	Input Voltage	- 0.5 to $V_{DD} + 0.5$	V
I_I	DC Input Current (any one input)	± 10	mA
P_{tot}	Total Power Dissipation (per package) Dissipation per Output Transistor for $T_{op} =$ Full Package-temperature Range	200 100	mW
T_{op}	Operating Temperature : HCC Types HCF Types	- 55 to + 125 - 40 to + 85	$^{\circ}C$
T_{stg}	Storage Temperature	- 65 to + 150	$^{\circ}C$

Stresses above those listed under "Absolute Maximum Ratings" may cause permanent damage to the device. This is a stress rating only and functional operation of the device at these or any other conditions above those indicated in the operational sections of this specification is not implied. Exposure to absolute maximum rating conditions for external periods may affect device reliability.

* All voltage are with respect to V_{SS} (GND).

RECOMMENDED OPERATING CONDITIONS

Symbol	Parameter	Value	Unit
V_{DD}	Supply Voltage : HCC Types HCF Types	3 to 18 3 to 15	V
V_I	Input Voltage	0 to V_{DD}	V
T_{op}	Operating Temperature : HCC Types HCF Types	- 55 to + 125 - 40 to + 85	$^{\circ}C$

LOGIC DIAGRAM

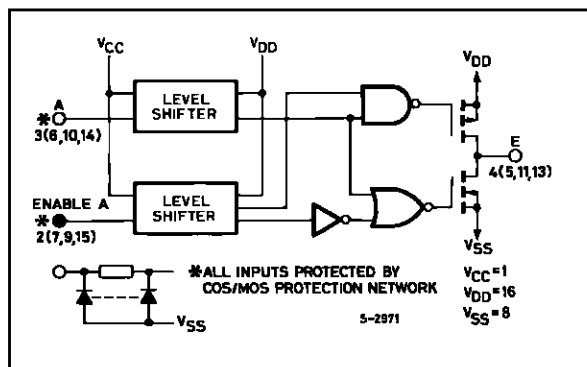

TRUTH TABLE

Mode	Inputs		Outputs
	A, B, C, D	Enable A, B, C, D	E, F, G, H
Low to High Level Shift	0	1	0
	1	1	1
	X	0	Z

LOGIC 0 = LOW (V_{SS})

X = Don't Care.

Z = High Impedance.

LOGIC 1 = V_{CC} at INPUTS and V_{DD} at OUTPUTS.

STATIC ELECTRICAL CHARACTERISTICS (over recommended operating conditions)

Symbol	Parameter		Test Conditions					Value						Unit	
			V _I (V)	V _O (V)	I _O (μ A)	V _{CC} (V)	V _{DD} (V)	T _{Low} *		25°C			T _{High} *		
								Min.	Max.	Min.	Typ.	Max.	Min.		Max.
I _L	Quiescent Current	HCC Types	0/ 5				5		1	0.02	1		30	μ A	
			0/10				10		2	0.02	2		60		
			0/15				15		4	0.02	4		120		
			0/20				20		20	0.04	20		600		
		HCF Types	0/ 5				5		4	0.02	4		30		
			0/10				10		8	0.02	8		60		
			0/15				15		16	0.02	16		120		
V _{OH}	Output High Voltage	0/ 5		< 1		5	4.95		4.95			4.95	V		
		0/10		< 1		10	9.95		9.95			9.95			
		0/15		< 1		15	14.95		14.95			14.95			
V _{OL}	Output Low Voltage	5/0		< 1		5		0.05			0.05		V		
		10/0		< 1		10		0.05			0.05			0.05	
		15/0		< 1		15		0.05			0.05			0.05	
V _{IH}	Input High Voltage		1/9	< 1	5	10	3.5		3.5			3.5	V		
			1.5/13.5	< 1	10	15	7		7			7			
V _{IL}	Input Low Voltage		1/9	< 1	5	10		1.5			1.5		V		
			1.5/13.5	< 1	10	15		3			3			3	
I _{OH}	Output Drive Current	HCC Types	0/ 5	2.5			5	- 2		- 1.6	- 3.2		- 1.15	mA	
			0/ 5	4.6			5	- 0.64		- 0.51	- 1		- 0.36		
			0/10	9.5			10	- 1.6		- 1.3	- 2.6		- 0.9		
			0/15	13.5			15	- 4.2		- 3.4	- 6.8		- 2.4		
		HCF Types	0/ 5	2.5			5	- 1.53		- 1.36	- 3.2		- 1.1		
			0/ 5	4.6			5	- 0.52		- 0.44	- 1		- 0.36		
			0/10	9.5			10	- 1.3		- 1.1	- 2.6		- 0.9		
0/15	13.5			15	- 3.6		- 3.0	- 6.8		- 2.4					
I _{OL}	Output Sink Current	HCC Types	0/ 5	0.4			5	0.64		0.51	1		0.36	mA	
			0/10	0.5			10	1.6		1.3	2.6		0.9		
			0/15	1.5			15	4.2		3.4	6.8		2.4		
		HCF Types	0/ 5	0.4			5	0.52		0.44	1		0.36		
			0/10	0.5			10	1.3		1.1	2.6		0.9		
			0/15	1.5			15	3.6		3.0	6.8		2.4		
I _{IH} , I _{IL}	Input Leakage Current	HCC Types	0/18	Any Input			18		\pm 0.1		\pm 10 ⁻⁵	\pm 0.1		\pm 1	μ A
		HCF Types	0/15	Any Input			15		\pm 0.3		\pm 10 ⁻⁵	\pm 0.3		\pm 1	

* T_{Low} = - 55°C for HCC device : - 40°C for HCF device.* T_{High} = + 125°C for HCC device : + 85°C for HCF device.The Noise Margin for both "1" and "0" level is : 1V min. with V_{DD} = 5V, 2V min. with V_{DD} = 10V, 2.5V min. with V_{DD} = 15V.

** Forced output disabled

STATIC ELECTRICAL CHARACTERISTICS (continued)

Symbol	Parameter		Test Conditions					Value						Unit	
			V _I (V)	V _O (V)	I _O (V)	V _{CC} (V)	V _{DD} (V)	T _{Low} *		25 °C			T _{High} *		
								Min.	Max.	Min.	Typ.	Max.	Min.		Max.
I _{OH} , I _{OL} **	3-State Output Leakage Current	HCC Types	0/18	0/18			18		± 0.4		±10 ⁻⁴	± 0.4		± 12	µA
		HCF Types	0/15	0/15			15		± 1.0		±10 ⁻⁴	± 1.0		± 7.5	
C _I	Input Capacitance		Any Input								5	7.5			pF

* T_{Low} = - 55°C for HCC device : - 40°C for HCF device.

* T_{High} = + 125°C for HCC device : + 85°C for HCF device.

The Noise Margin for both "1" and "0" levels is : 1V min. with V_{DD} = 5V, 2V min. with V_{DD} = 10V, 2.5V min. with V_{DD} = 15V.

** Forced output disabled

DYNAMIC ELECTRICAL CHARACTERISTICS (T_{amb} = 25°C, C_L = 50pF, R_L = 200kΩ, typical temperature coefficient for all V_{DD} values is 0.3%/°C, all input rise and fall time = 20ns)

Symbol	Parameter	Shifting Mode	Test Conditions		Value			Unit
			V _{CC} (V)	V _{DD} (V)	Min.	Typ.	Max.	
t _{PHL} , t _{PLH}	Propagation Delay Time (data input to output) High to Low Level	L - H	5	10		300	600	ns
			5	15		220	440	
			10	15		180	360	
		H - L	10	5		850	1600	
			15	5		850	1600	
			15	10		290	580	
	Low to High Level	L - H	5	10		130	260	ns
			5	15		120	240	
			10	15		70	140	
		H - L	10	5		230	460	
			15	5		230	460	
			15	10		80	160	
t _{PHZ}	3-State Disable Delay Time Output High to High Impedance	L - H	5	10		60	120	ns
			5	15		50	100	
			10	15		35	70	
		H - L	10	5		120	240	
			15	5		120	240	
			15	10		40	80	
t _{PZH}	High Impedance to Output High	L - H	5	10		320	640	ns
			5	15		230	460	
			10	15		180	360	
		H - L	10	5		800	1500	
			15	5		800	1500	
			15	10		280	560	
t _{PLZ}	Output Low to High Impedance	L - H	5	10		370	740	ns
			5	15		300	600	
			10	15		250	500	
		H - L	10	5		850	1600	
			15	5		850	1600	
			15	10		350	700	

DYNAMIC ELECTRICAL CHARACTERISTICS (continued)

Symbol	Parameter	Shifting Mode	Test Conditions		Value			Unit
			V _{CC} (V)	V _{DD} (V)	Min.	Typ.	Max.	
t _{PZL}	High Impedance to Output Low	L - H	5	10		100	200	ns
			5	15		80	160	
			10	15		40	80	
		H - L	10	5		120	240	
			15	5		120	240	
			15	10		40	80	
t _{THL} , t _{TLH}	Transition Time	L - H	5	10		50	100	ns
			5	15		40	80	
			10	15		40	80	
		H - L	10	5		100	200	
			15	5		100	200	
			15	10		50	100	

Output Low (sink) Current Characteristics.

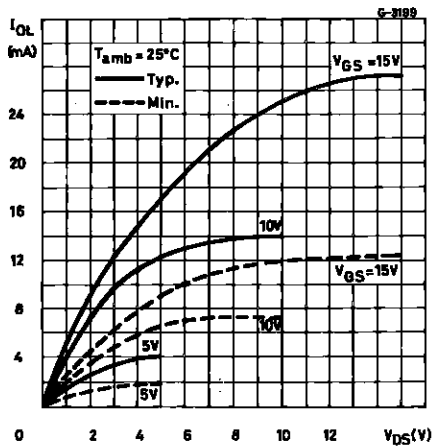

Output High (source) Current Characteristics.

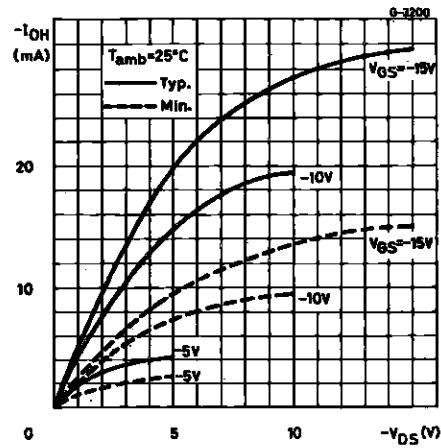

Typical Transition Times. Load Capacitance.

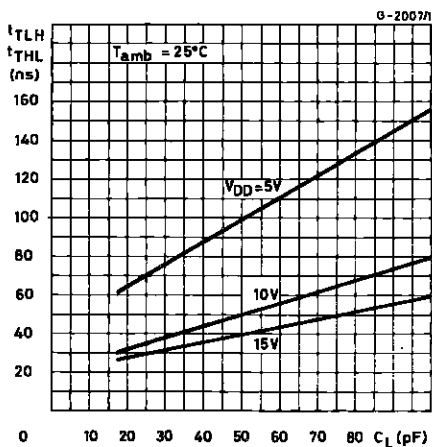

Typical High-to-low Propagation Delay Time vs. Load Capacitance.

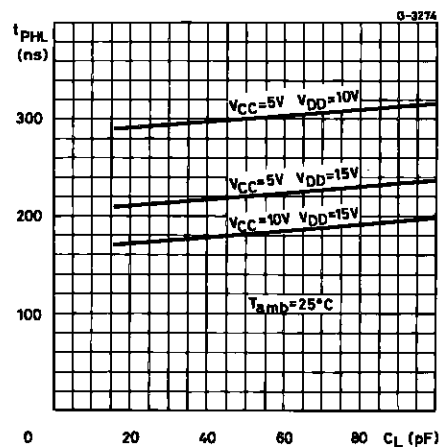

HCC/HCF40109B

Typical Low-to-high Propagation Delay Time vs. Load Capacitance.

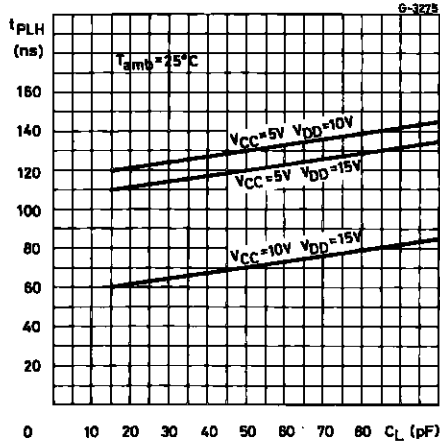

Typical Input Switching vs. High-level Supply Voltage.

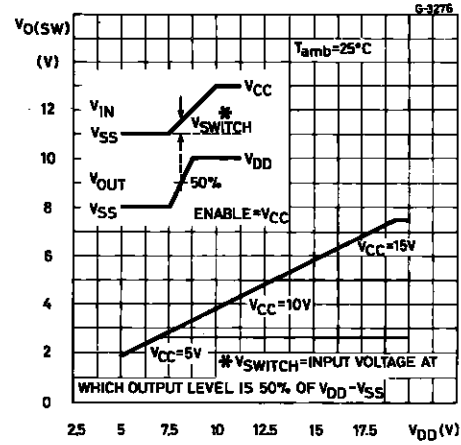

High-level Supply Voltage vs. Low-level Supply Voltage.

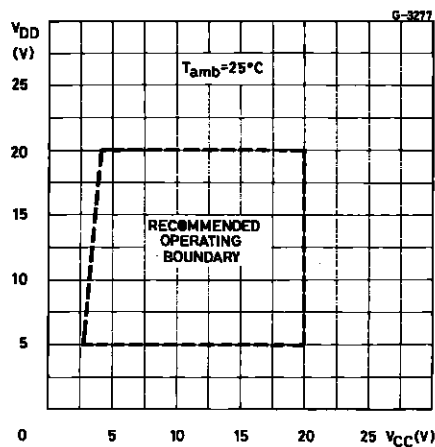

Typical Dynamic Power Dissipation vs. Input Frequency.

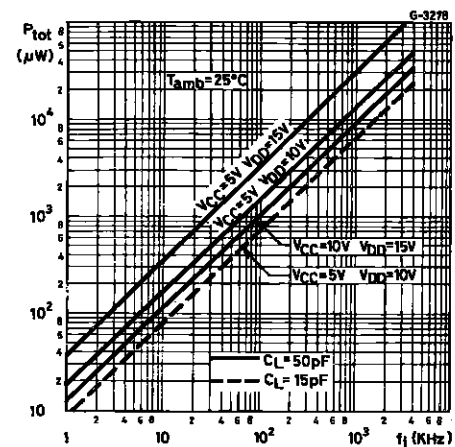

TEST CIRCUITS

Output Enable Delay Times Test Circuit and Waveforms.

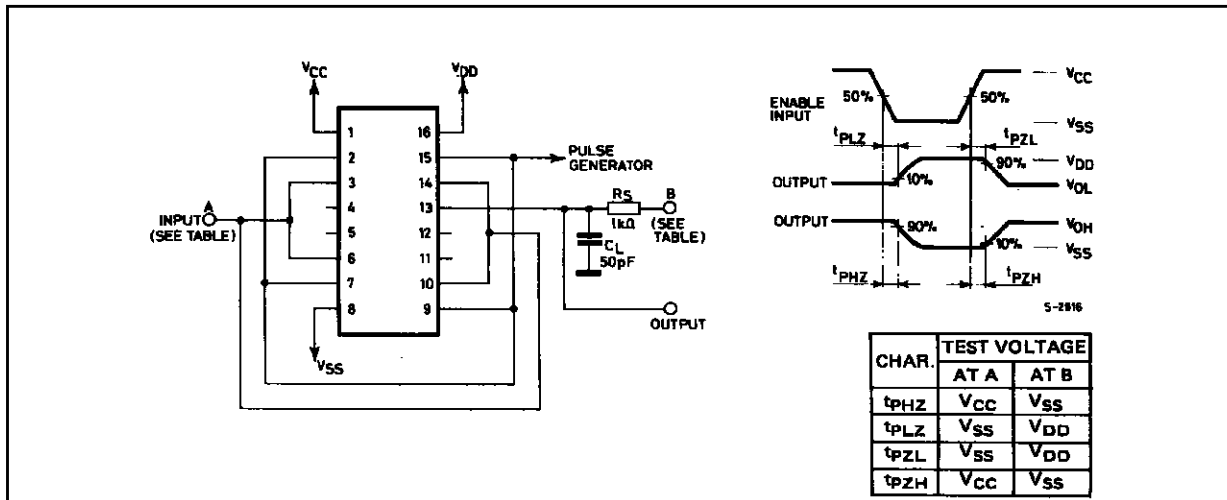

TEST CIRCUITS (continued)

Quiescent Device Current.

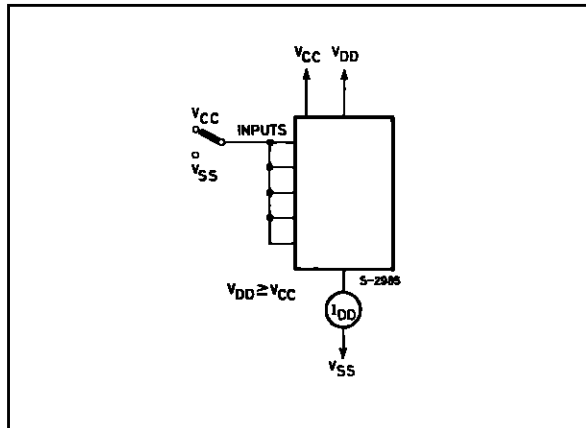

Input Voltage.

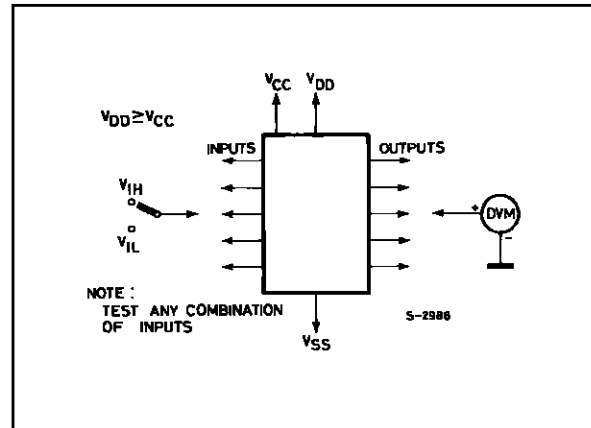

Input Leakage Current.

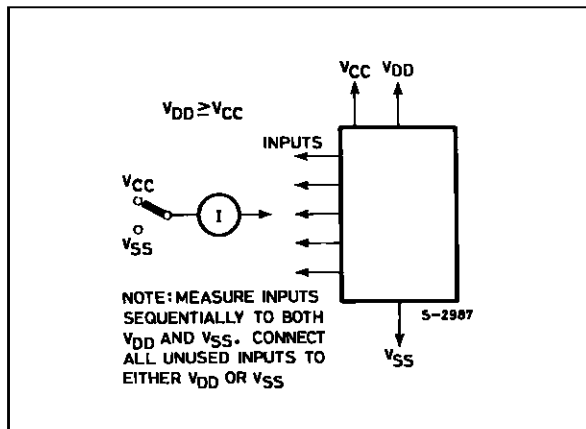

Dynamic Power Dissipation.

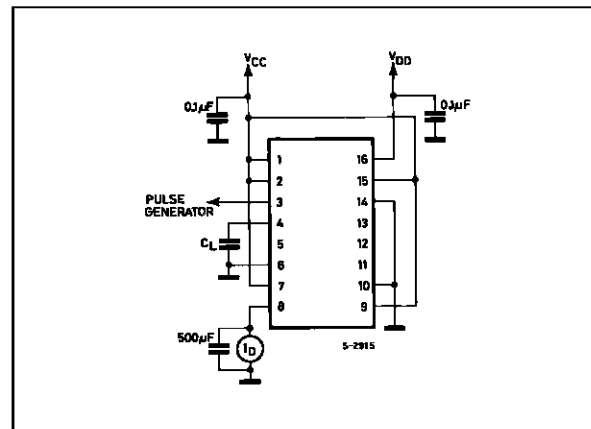

Plastic DIP16 (0.25) MECHANICAL DATA

DIM.	mm			inch		
	MIN.	TYP.	MAX.	MIN.	TYP.	MAX.
a1	0.51			0.020		
B	0.77		1.65	0.030		0.065
b		0.5			0.020	
b1		0.25			0.010	
D			20			0.787
E		8.5			0.335	
e		2.54			0.100	
e3		17.78			0.700	
F			7.1			0.280
I			5.1			0.201
L		3.3			0.130	
Z			1.27			0.050

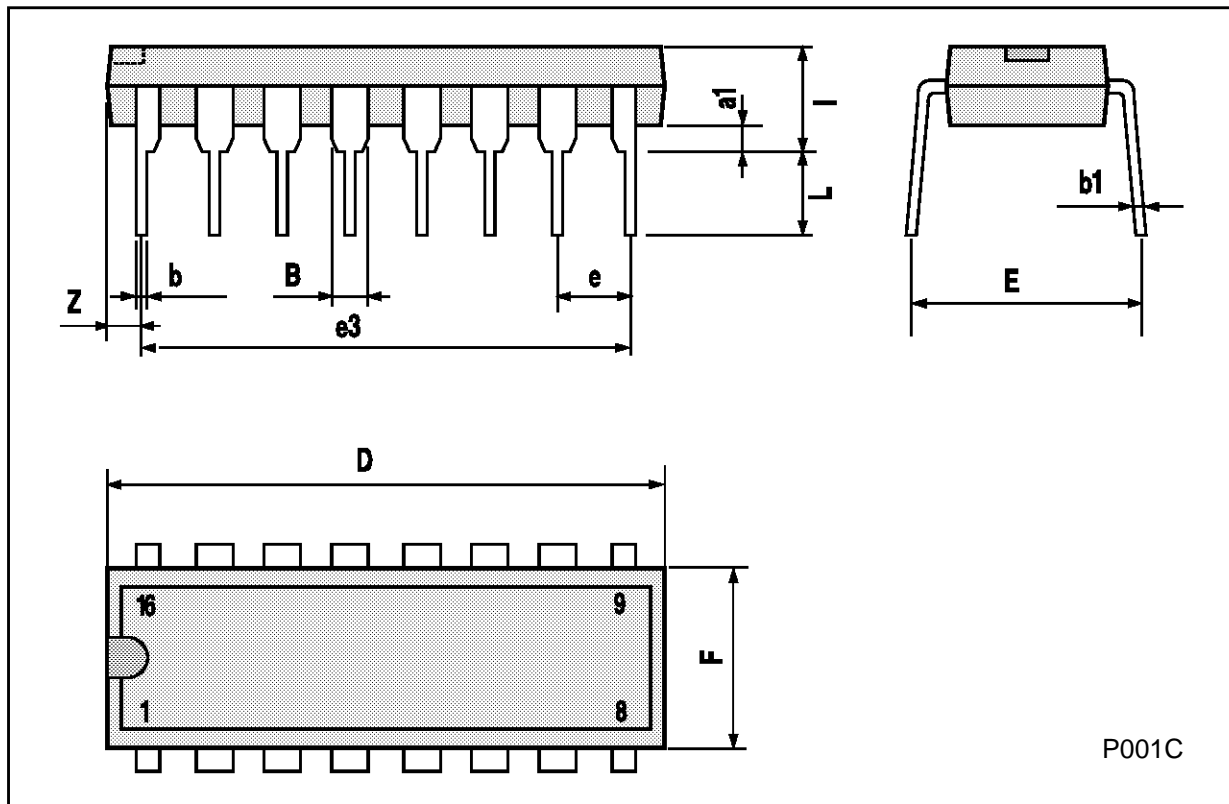

P001C

Ceramic DIP16/1 MECHANICAL DATA

DIM.	mm			inch		
	MIN.	TYP.	MAX.	MIN.	TYP.	MAX.
A			20			0.787
B			7			0.276
D		3.3			0.130	
E	0.38			0.015		
e3		17.78			0.700	
F	2.29		2.79	0.090		0.110
G	0.4		0.55	0.016		0.022
H	1.17		1.52	0.046		0.060
L	0.22		0.31	0.009		0.012
M	0.51		1.27	0.020		0.050
N			10.3			0.406
P	7.8		8.05	0.307		0.317
Q			5.08			0.200



SO16 (Narrow) MECHANICAL DATA

DIM.	mm			inch		
	MIN.	TYP.	MAX.	MIN.	TYP.	MAX.
A			1.75			0.068
a1	0.1		0.2	0.004		0.007
a2			1.65			0.064
b	0.35		0.46	0.013		0.018
b1	0.19		0.25	0.007		0.010
C		0.5			0.019	
c1	45° (typ.)					
D	9.8		10	0.385		0.393
E	5.8		6.2	0.228		0.244
e		1.27			0.050	
e3		8.89			0.350	
F	3.8		4.0	0.149		0.157
G	4.6		5.3	0.181		0.208
L	0.5		1.27	0.019		0.050
M			0.62			0.024
S	8° (max.)					



P013H

PLCC20 MECHANICAL DATA

DIM.	mm			inch		
	MIN.	TYP.	MAX.	MIN.	TYP.	MAX.
A	9.78		10.03	0.385		0.395
B	8.89		9.04	0.350		0.356
D	4.2		4.57	0.165		0.180
d1		2.54			0.100	
d2		0.56			0.022	
E	7.37		8.38	0.290		0.330
e		1.27			0.050	
e3		5.08			0.200	
F		0.38			0.015	
G			0.101			0.004
M		1.27			0.050	
M1		1.14			0.045	



Information furnished is believed to be accurate and reliable. However, SGS-THOMSON Microelectronics assumes no responsibility for the consequences of use of such information nor for any infringement of patents or other rights of third parties which may result from its use. No license is granted by implication or otherwise under any patent or patent rights of SGS-THOMSON Microelectronics. Specifications mentioned in this publication are subject to change without notice. This publication supersedes and replaces all information previously supplied. SGS-THOMSON Microelectronics products are not authorized for use as critical components in life support devices or systems without express written approval of SGS-THOMSON Microelectronics.

© 1994 SGS-THOMSON Microelectronics - All Rights Reserved

SGS-THOMSON Microelectronics GROUP OF COMPANIES
Australia - Brazil - France - Germany - Hong Kong - Italy - Japan - Korea - Malaysia - Malta - Morocco - The Netherlands -
Singapore - Spain - Sweden - Switzerland - Taiwan - Thailand - United Kingdom - U.S.A