

10 TO 4 LINE BCD PRIORITY ENCODER

- ENCODES 10 LINE TO 4 LINE BCD
- ACTIVE LOW INPUTS AND OUTPUTS
- STANDARDIZED, SYMMETRICAL OUTPUT CHARACTERIZATION
- 100 % TESTED FOR QUIESCENT CURRENT AT 20 V
- 5V, 10V AND 15V PARAMETRIC RATINGS
- MAXIMUM INPUT CURRENT OF 1 μ A AT 18V OVER FULL PACKAGE TEMPERATURE RANGE; 100 nA AT 18 V AND 25 °C
- NOISE MARGIN (FULL PACKAGE TEMPERATURE RANGE): 1V AT $V_{DD} = 5V$, 2V AT $V_{DD} = 10V$, 2.5V AT $V_{DD} = 15V$

APPLICATIONS:

- KEYBOARD ENCODING
- 10 LINE TO BCD ENCODING
- RANGE SELECTION

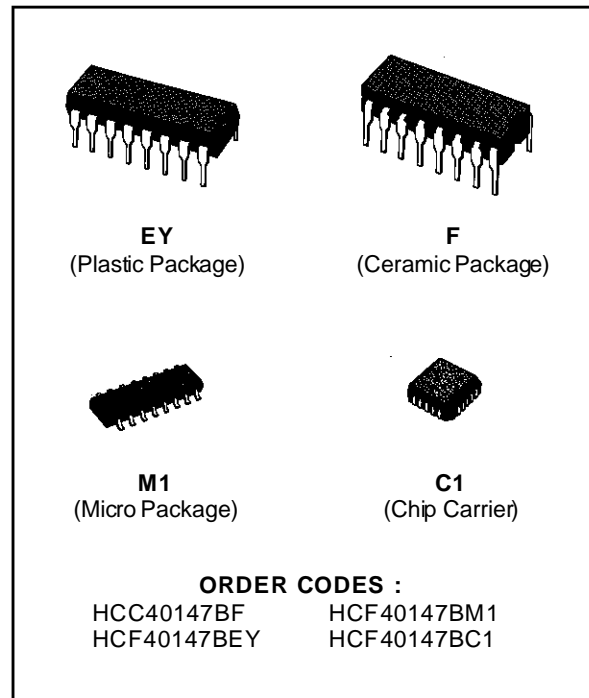

DESCRIPTION

The **HCC/HCF40147B** CMOS encoder features priority encoding of the inputs to ensure that only the highest order data line is encoded. Ten data input lines (0-9) are encoded to four line (8, 4, 2, 1) BCD. The highest priority line is line 9. All four output lines are logic 1 (V_{SS}) when all input lines are logic 0. All inputs and outputs are buffered, and each output can drive one TTL Low Power Schottky load. The **HCC/HCF40147** is functionally similar to the T54/T74LS147 if pin 15 is tied low.

The **HCC/HCF40147B** types are supplied in 16 lead plastic or ceramic and plastic micropackage.

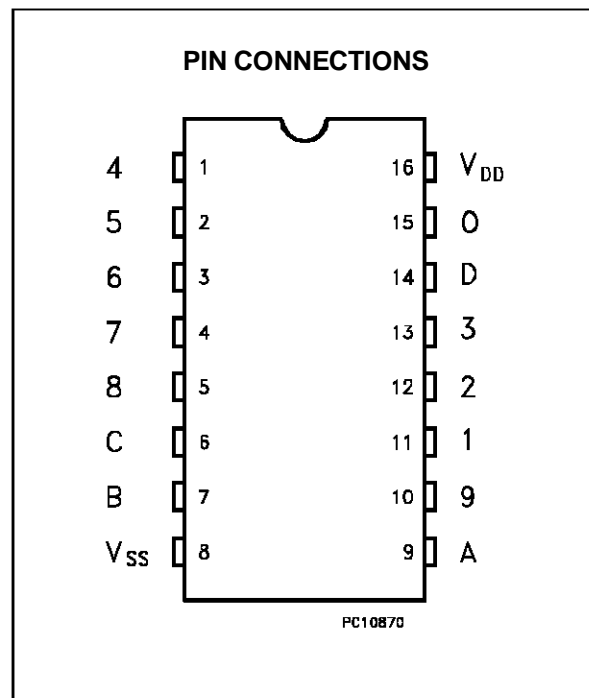

HCC/HCF40147B

ABSOLUTE MAXIMUM RATING

Symbol	Parameter	Value	Unit
V _{DD} *	Supply Voltage: HCC Types HCF Types	-0.5 to +20	V
		-0.5 to +18	V
V _i	Input Voltage	-0.5 to V _{DD} + 0.5	V
I _i	DC Input Current (any one input)	± 10	mA
P _{tot}	Total Power Dissipation (per package) Dissipation per Output Transistor for Top = Full Package Temperature Range	200	mW
		100	mW
T _{op}	Operating Temperature: HCC Types HCF Types	-55 to +125	°C
		-40 to +85	°C
T _{stg}	Storage Temperature	-65 to +150	°C

Stresses above those listed under "Absolute Maximum Ratings" may cause permanent damage to the device. This is a stress rating only and functional operation of the device at these or any other conditions above those indicated in the operational sections of this specification is not implied. Exposure to absolute maximum rating conditions for external periods may affect device reliability.

* All voltage values are referred to V_{SS} pin voltage.

RECOMMENDED OPERATING CONDITIONS

Symbol	Parameter	Value	Unit
V _{DD}	Supply Voltage: HCC Types HCF Types	3 to 18	V
		3 to 15	V
V _i	Input Voltage	0 to V _{DD}	V
T _{op}	Operating Temperature: HCC Types HCF Types	-55 to +125	°C
		-40 to +85	°C

TRUTH TABLE

INPUT										OUTPUTS			
0	1	2	3	4	5	6	7	8	9	D	C	B	A
0	0	0	0	0	0	0	0	0	0	1	1	1	1
1	0	0	0	0	0	0	0	0	0	0	0	0	0
X	1	0	0	0	0	0	0	0	0	0	0	0	1
X	X	1	0	0	0	0	0	0	0	0	0	1	0
X	X	X	1	0	0	0	0	0	0	0	0	1	1
X	X	X	X	1	0	0	0	0	0	0	1	0	0
X	X	X	X	X	1	0	0	0	0	0	1	1	0
X	X	X	X	X	X	1	0	0	0	0	1	1	1
X	X	X	X	X	X	X	1	0	0	1	0	0	0
X	X	X	X	X	X	X	X	X	1	1	0	0	1

0 = High Level, 1 = Low Level, X = Don't Care

LOGIC DIAGRAM

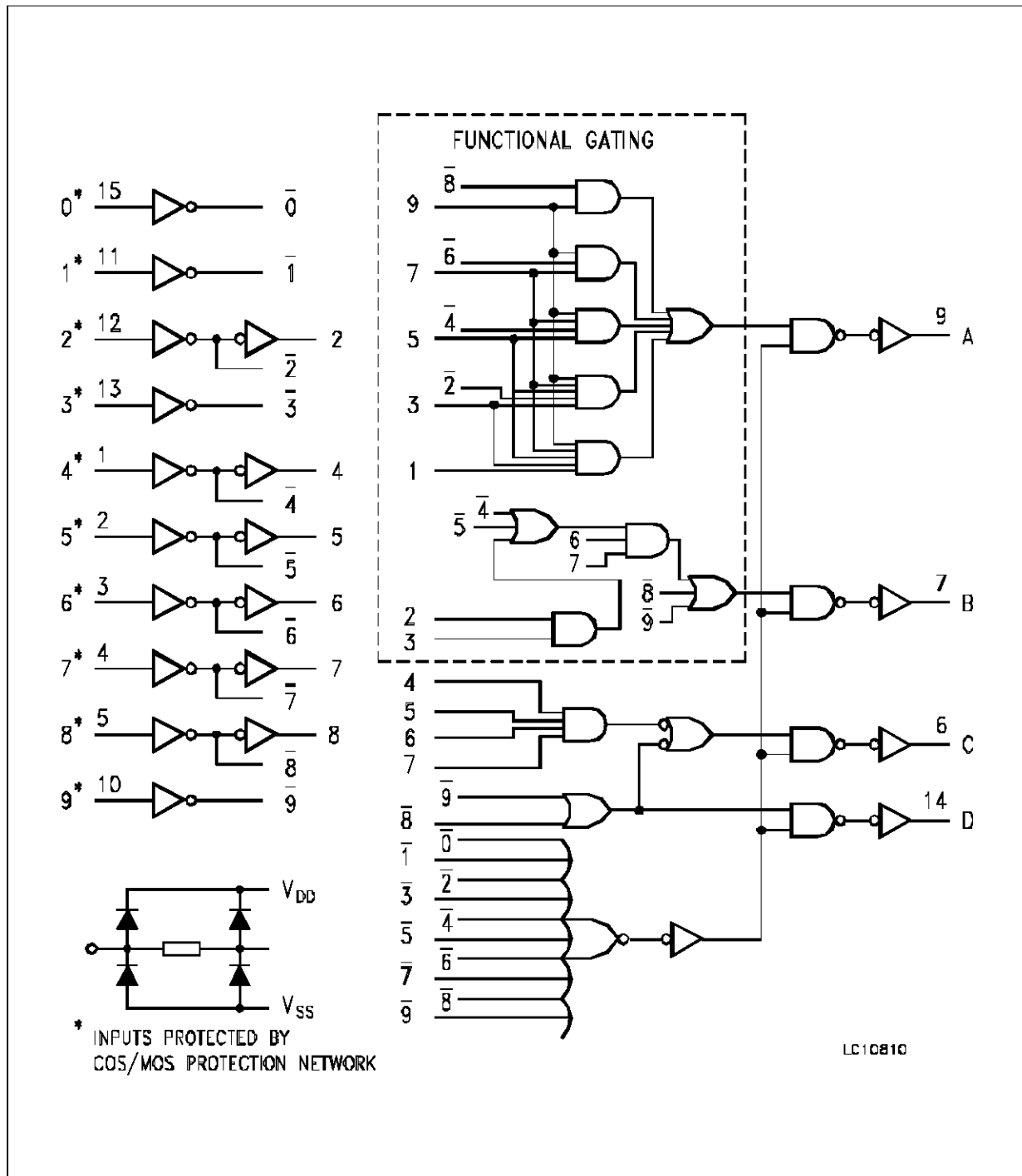

STATIC ELECTRICAL CHARACTERISTICS (over recommended operating conditions)

Symbol	Parameter		Test Conditions				Value						Unit	
			V _I (V)	V _O (V)	I _O (μ A)	V _{DD} (V)	T _{LOW} *		25 °C			T _{HIGH} *		
							Min.	Max.	Min.	Typ.	Max.	Min.		Max.
I _L	Quiescent Current	HCC Types	0/5			5		1		0.02	1		30	μ A
			0/10			10		2		0.02	2		60	
			0/15			15		4		0.02	4		120	
			0/20			20		20		0.04	20		600	
		HCF Types	0/5			5		4		0.02	4		30	
			0/10			10		8		0.02	8		60	
V _{OH}	Output High Voltage		0/5		< 1	5	4.95		4.95			4.95		V
			0/10		< 1	10	9.95		9.95			9.95		
			0/15		< 1	15	14.95		14.95			14.95		
V _{OL}	Output Low Voltage		5/0		< 1	5		0.05			0.05		0.05	V
			10/0		< 1	10		0.05			0.05		0.05	
			15/0		< 1	15		0.05			0.05		0.05	
V _{IH}	Input High Voltage			0.5/4.5	< 1	5	3.5		3.5			3.5		V
				1/9	< 1	10	7		7			7		
				1.5/13.5	< 1	15	11		11			11		
V _{IL}	Input Low Voltage			4.5/0.5	< 1	5		1.5			1.5		1.5	V
				9/1	< 1	10		3			3		3	
				13.5/1.5	< 1	15		4			4		4	
I _{OH}	Output Drive Current	HCC Types	0/5	2.5		5	-2		-1.6	-3.2		-1.15		mA
			0/5	4.6		5	-0.64		-0.51	-1		-0.36		
			0/10	9.5		10	-1.6		-1.3	-2.6		-0.9		
			0/15	13.5		15	-4.2		-3.4	-6.8		-2.4		
		HCF Types	0/5	2.5		5	-1.53		-1.36	-3.2		-1.1		
			0/5	4.6		5	-0.52		-0.44	-1		-0.36		
			0/10	9.5		10	-1.3		-1.1	-2.6		-0.9		
			0/15	13.5		15	-3.6		-3.0	-6.8		-2.4		
I _{OL}	Output Sink Current	HCC Types	0/5	0.4		5	0.64		0.51	1		0.36	mA	
			0/10	0.5		10	1.6		1.3	2.6		0.9		
			0/15	1.5		15	4.2		3.4	6.8		2.4		
		HCF Types	0/5	0.4		5	0.52		0.44	1		0.36		
			0/10	0.5		10	1.3		1.1	2.6		0.9		
			0/15	1.5		15	3.6		3.0	6.8		2.4		
I _{IH} , I _{IL}	Input Leakage Current		0/18	Any Input		18		\pm 0.1		\pm 10 ⁻⁵	\pm 0.1		\pm 1	μ A
			0/15			15		\pm 0.3		\pm 10 ⁻⁵	\pm 0.3		\pm 1	μ A
C _I	Input Capacitance		Any Input						5	7.5			pF	

* T_{LOW} = -55 °C for HCC device; -40 °C for HCF device.

* T_{HIGH} = +125 °C for HCC device; +85 °C for HCF device.

The Noise Margin for both "1" and "0" level is: 1V min. with V_{DD} = 5V, 2V min. with V_{DD} = 10V, 2.5V min. with V_{DD} = 15V

DYNAMIC ELECTRICAL CHARACTERISTICS ($T_{amb} = 25\text{ }^{\circ}\text{C}$, $C_L = 50\text{ pF}$, $R_L = 200\text{ K}\Omega$, typical temperature coefficient for all V_{DD} values is $03\text{ } \%/^{\circ}\text{C}$, all input rise and fall times = 20 ns)

Symbol	Parameter	Test Conditions		Value			Unit
			V_{DD} (V)	Min.	Typ.	Max.	
t_{PLH} t_{PHL}	Propagation Delay Time In Phase Output		5		450	900	ns
			10		200	400	
			15		150	300	
t_{PLH} t_{PHL}	Propagation Delay Time Out of Phase Output		5		425	850	ns
			10		175	350	
			15		125	250	
t_{TLH} t_{THL}	Transition Time		5		100	200	ns
			10		50	100	
			15		40	80	
C_i	Input Capacitance				5	7.5	pF

Typical Output Low (source) Current Characteristics

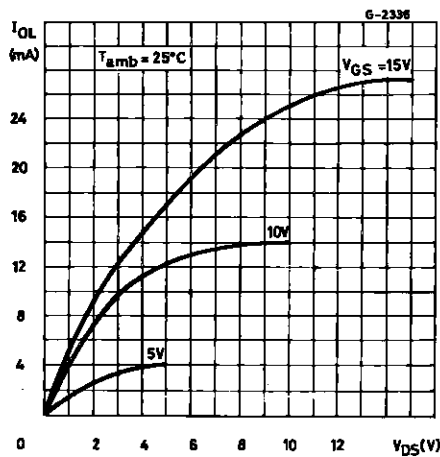

Minimum Output Low (source) Current Characteristics

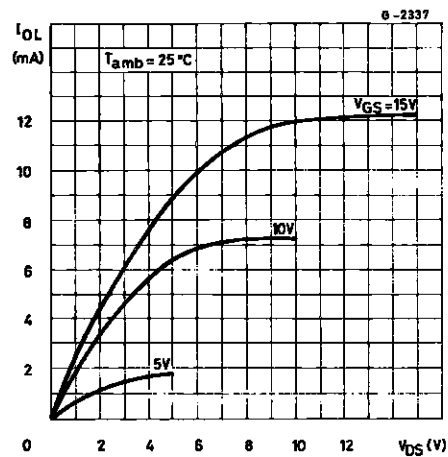

Typical Output High (source) Current Characteristics

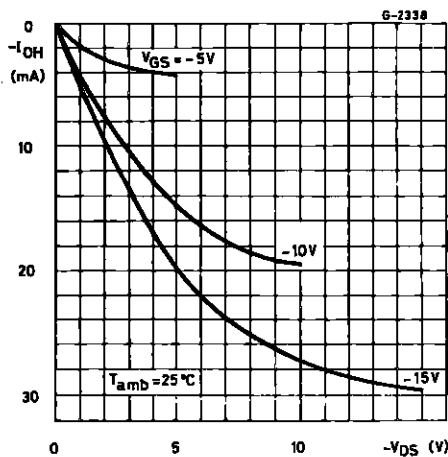

Minimum Output High (source) Current Characteristics

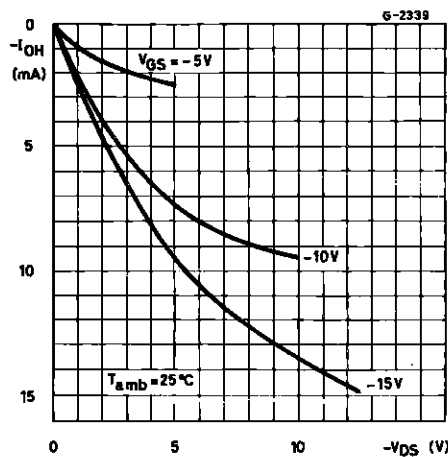

Propagation Delay Time vs Load Capacitance

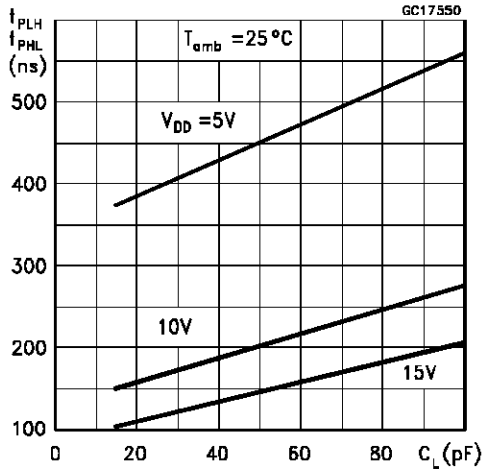

Typical Transition Time vs Load Capacitance

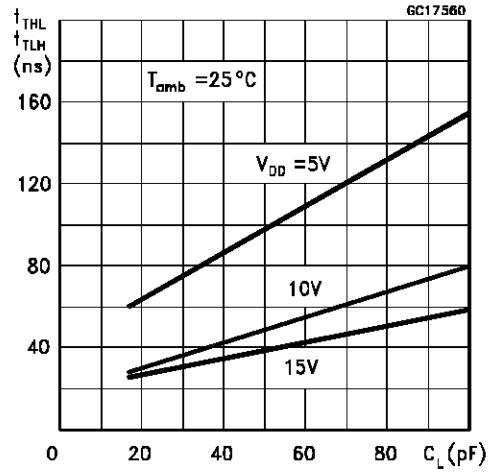

Typical Dynamic Power Dissipation vs Input Frequency

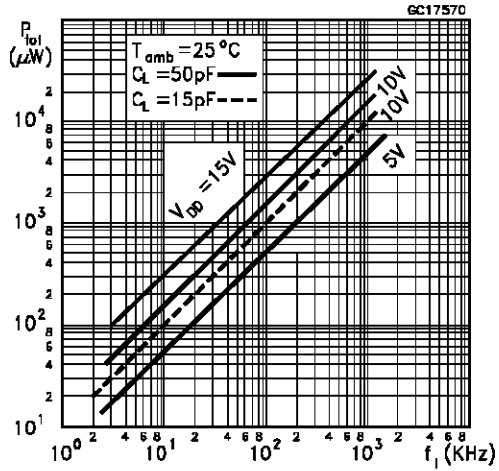

TEST CIRCUITS

Quiescent Device Current

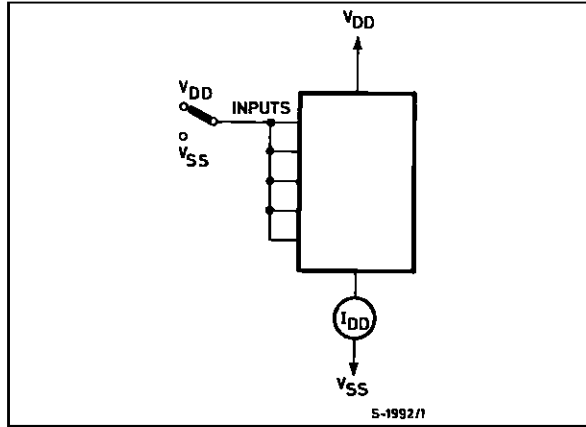

Noise Immunity.

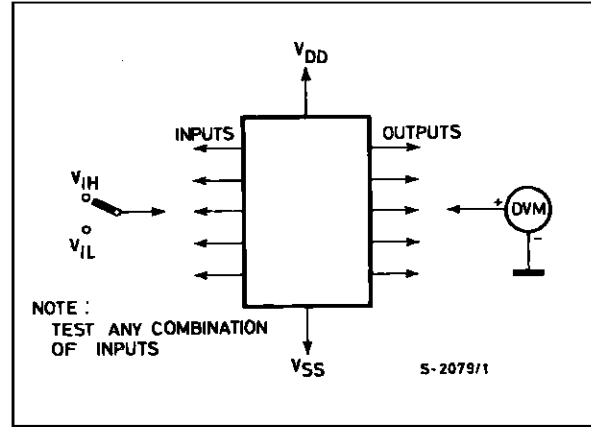

Input Leakage Current.

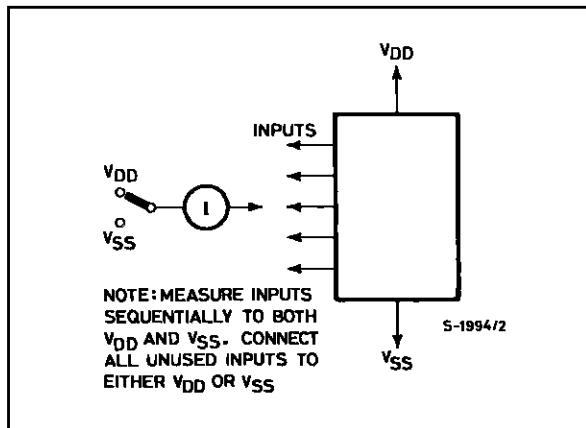

Dynamic Power Dissipation Test Circuit

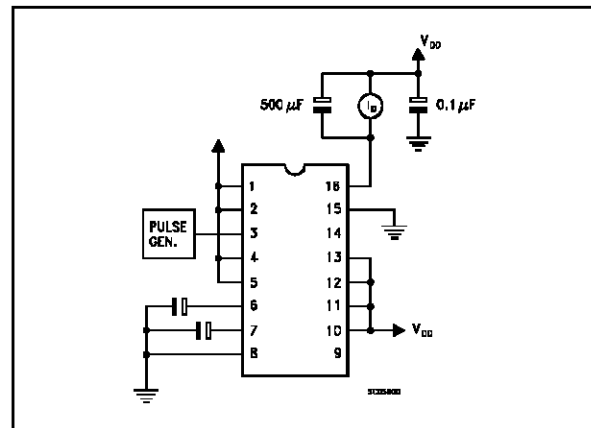

Plastic DIP16 (0.25) MECHANICAL DATA

DIM.	mm			inch		
	MIN.	TYP.	MAX.	MIN.	TYP.	MAX.
a1	0.51			0.020		
B	0.77		1.65	0.030		0.065
b		0.5			0.020	
b1		0.25			0.010	
D			20			0.787
E		8.5			0.335	
e		2.54			0.100	
e3		17.78			0.700	
F			7.1			0.280
I			5.1			0.201
L		3.3			0.130	
Z			1.27			0.050



P001C

Ceramic DIP16/1 MECHANICAL DATA

DIM.	mm			inch		
	MIN.	TYP.	MAX.	MIN.	TYP.	MAX.
A			20			0.787
B			7			0.276
D		3.3			0.130	
E	0.38			0.015		
e3		17.78			0.700	
F	2.29		2.79	0.090		0.110
G	0.4		0.55	0.016		0.022
H	1.17		1.52	0.046		0.060
L	0.22		0.31	0.009		0.012
M	0.51		1.27	0.020		0.050
N			10.3			0.406
P	7.8		8.05	0.307		0.317
Q			5.08			0.200

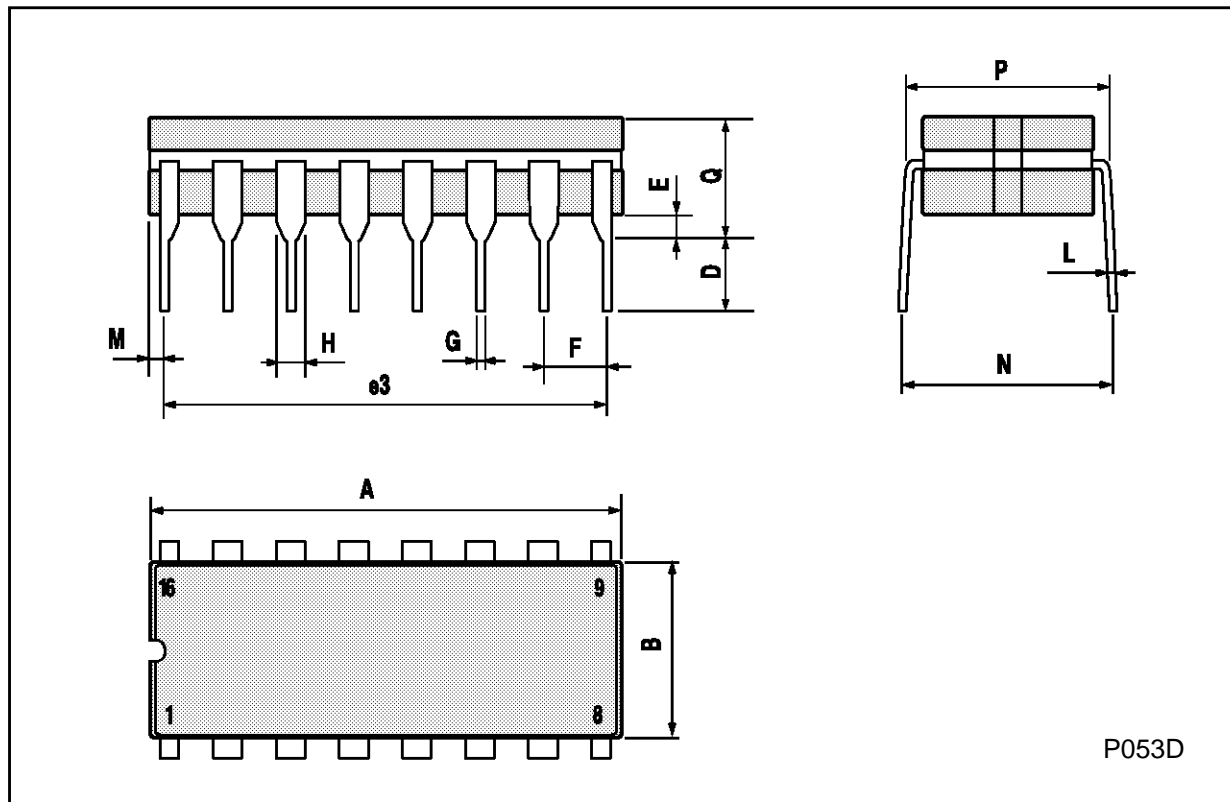

SO16 (Narrow) MECHANICAL DATA

DIM.	mm			inch		
	MIN.	TYP.	MAX.	MIN.	TYP.	MAX.
A			1.75			0.068
a1	0.1		0.2	0.004		0.007
a2			1.65			0.064
b	0.35		0.46	0.013		0.018
b1	0.19		0.25	0.007		0.010
C		0.5			0.019	
c1	45° (typ.)					
D	9.8		10	0.385		0.393
E	5.8		6.2	0.228		0.244
e		1.27			0.050	
e3		8.89			0.350	
F	3.8		4.0	0.149		0.157
G	4.6		5.3	0.181		0.208
L	0.5		1.27	0.019		0.050
M			0.62			0.024
S	8° (max.)					



P013H

PLCC20 MECHANICAL DATA

DIM.	mm			inch		
	MIN.	TYP.	MAX.	MIN.	TYP.	MAX.
A	9.78		10.03	0.385		0.395
B	8.89		9.04	0.350		0.356
D	4.2		4.57	0.165		0.180
d1		2.54			0.100	
d2		0.56			0.022	
E	7.37		8.38	0.290		0.330
e		1.27			0.050	
e3		5.08			0.200	
F		0.38			0.015	
G			0.101			0.004
M		1.27			0.050	
M1		1.14			0.045	



Information furnished is believed to be accurate and reliable. However, SGS-THOMSON Microelectronics assumes no responsibility for the consequences of use of such information nor for any infringement of patents or other rights of third parties which may result from its use. No license is granted by implication or otherwise under any patent or patent rights of SGS-THOMSON Microelectronics. Specifications mentioned in this publication are subject to change without notice. This publication supersedes and replaces all information previously supplied. SGS-THOMSON Microelectronics products are not authorized for use as critical components in life support devices or systems without express written approval of SGS-THOMSON Microelectronics.

© 1994 SGS-THOMSON Microelectronics - All Rights Reserved

SGS-THOMSON Microelectronics GROUP OF COMPANIES

Australia - Brazil - France - Germany - Hong Kong - Italy - Japan - Korea - Malaysia - Malta - Morocco - The Netherlands -
Singapore - Spain - Sweden - Switzerland - Taiwan - Thailand - United Kingdom - U.S.A