

QUAD BILATERAL SWITCH

- 20V DIGITAL OR $\pm 10V$ PEAK-TO-PEAK SWITCHING
- 280 Ω TYPICAL ON RESISTANCE FOR 15V OPERATION
- SWITCH ON RESISTANCE MATCHED TO WITHIN 10 Ω TYP. OVER 15V SIGNAL INPUT RANGE
- HIGH ON/OFF OUTPUT-VOLTAGE RATIO : 65dB TYP. @ $f_{is} = 10\text{kHz}$, $R_L = 10\text{k}\Omega$
- HIGH DEGREE OF LINEARITY : < 0.5% DISTORTION TYP. @ $f_{is} = 1\text{kHz}$, $V_{is} = 5\text{V}_{pp}$, $V_{DD} - V_{SS} \geq 10\text{V}$, $R_L = 10\text{k}\Omega$
- EXTREMELY LOW OFF SWITCH LEAKAGE RESULTING IN VERY LOW OFFSET CURRENT AND HIGH EFFECTIVE OFF RESISTANCE: 100pA TYP. @ $V_{DD} - V_{SS} = 18\text{V}$, $T_{amb} = 25^\circ\text{C}$
- EXTREMELY HIGH CONTROL INPUT IMPEDANCE (control circuit isolated from signal circuit 10¹² Ω typ.)
- LOW CROSSTALK BETWEEN SWITCHES : 50dB TYP. @ $f_{is} = 0.9\text{MHz}$, $R_L = 1\text{k}\Omega$
- MATCHED CONTROL-INPUT TO SIGNAL-OUTPUT CAPACITANCE : REDUCES OUTPUT SIGNAL TRANSIENTS
- FREQUENCY RESPONSE' SWITCH ON = 40MHz (typ.)
- QUIESCENT CURRENT SPECIFIED TO 20V FOR HCC DEVICE
- 5V, 10V, AND 15V PARAMETRIC RATINGS
- INPUT CURRENT OF 100nA AT 18V AND 25 $^\circ\text{C}$ FOR HCC DEVICE
- 100% TESTED FOR QUIESCENT CURRENT
- MEETS ALL REQUIREMENTS OF JEDEC TENTATIVE STANDARD N^o 13A, "STANDARD SPECIFICATIONS FOR DESCRIPTION OF "B" SERIES CMOS DEVICES"

DESCRIPTION

The **HCC4016B** (extended temperature range) and **HCF4016B** (intermediate temperature range) are monolithic integrated circuit, available in 14-lead dual in-line plastic or ceramic package and plastic micropackage.

The **HCC/HCF4016B** Series types are quad bilateral switches intended for the transmission or multiplexing

of analog or digital signals. Each of the four independent bilateral switches has a single control signal input which simultaneously biases both the p and n device in a given switch ON or OFF.

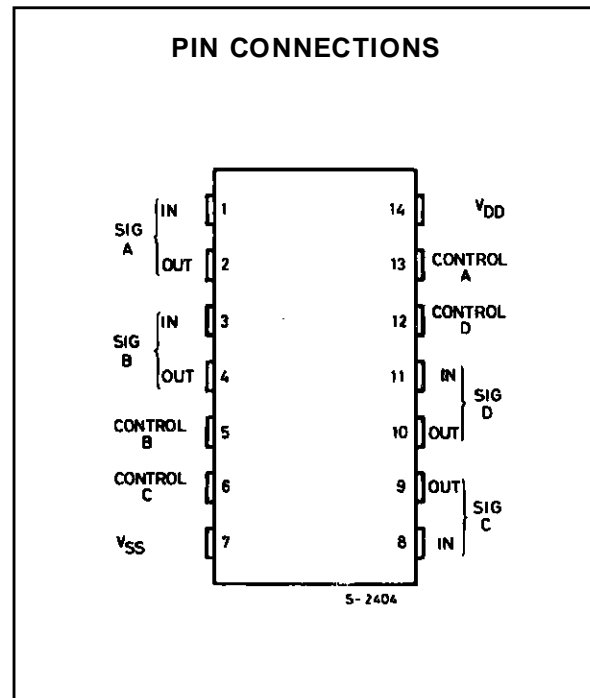
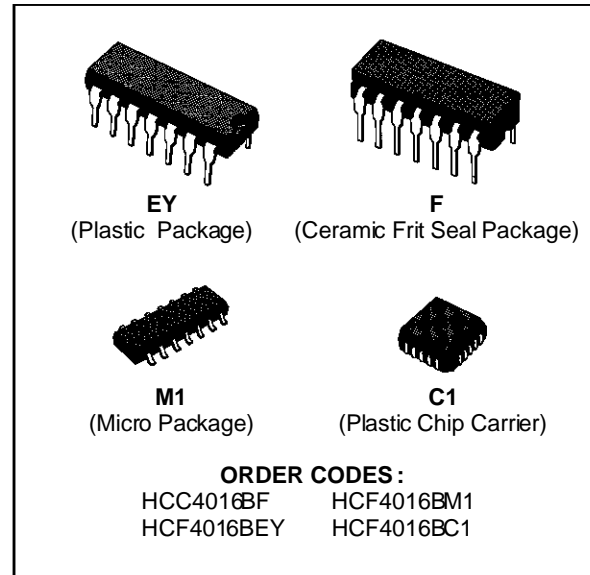

HCC/HCF4016B

FUNCTIONAL DIAGRAM

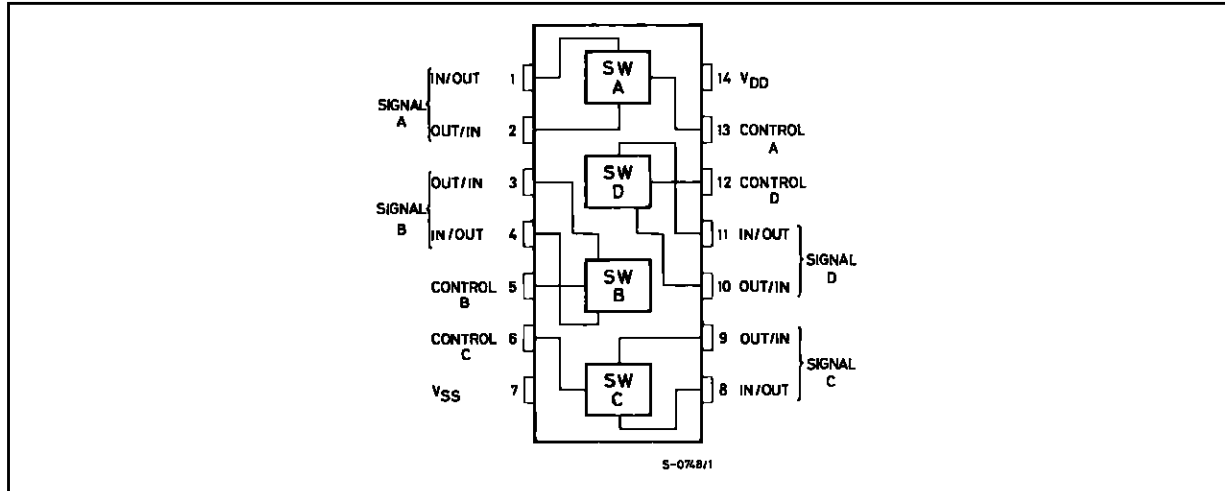

ABSOLUTE MAXIMUM RATINGS

Symbol	Parameter	Value	Unit
V_{DD}^*	Supply Voltage : HCC Types HCF Types	- 0.5 to + 20 - 0.5 to + 18	V
V_i	Input Voltage	- 0.5 to $V_{DD} + 0.5$	V
I_i	DC Input Current (any one input)	± 10	mA
P_{tot}	Total Power Dissipation (per package)	200	mW
	Dissipation per Output Transistor for $T_{op} =$ Full Package-temperature Range	100	mW
T_{op}	Operating Temperature : HCC Types HCF Types	- 55 to + 125	$^{\circ}C$
		- 40 to + 85	$^{\circ}C$
T_{stg}	Storage Temperature	- 65 to + 150	$^{\circ}C$

Stresses above those listed under "Absolute Maximum Ratings" may cause permanent damage to the device. This is a stress rating only and functional operation of the device at these or any other conditions above those indicated in the operational sections of this specification is not implied. Exposure to absolute maximum rating conditions for external periods may affect device reliability.

* All voltage values are referred to V_{SS} pin voltage.

RECOMMENDED OPERATING CONDITIONS

Symbol	Parameter	Value	Unit
V_{DD}	Supply Voltage : HCC Types HCF Types	3 to 18	V
		3 to 15	V
V_i	Input Voltage	0 to V_{DD}	V
T_{op}	Operating Temperature : HCC Types HCF Types	- 55 to + 125	$^{\circ}C$
		- 40 to + 85	$^{\circ}C$

SCHEMATIC DIAGRAM

1 OF 4 IDENTICAL SECTION

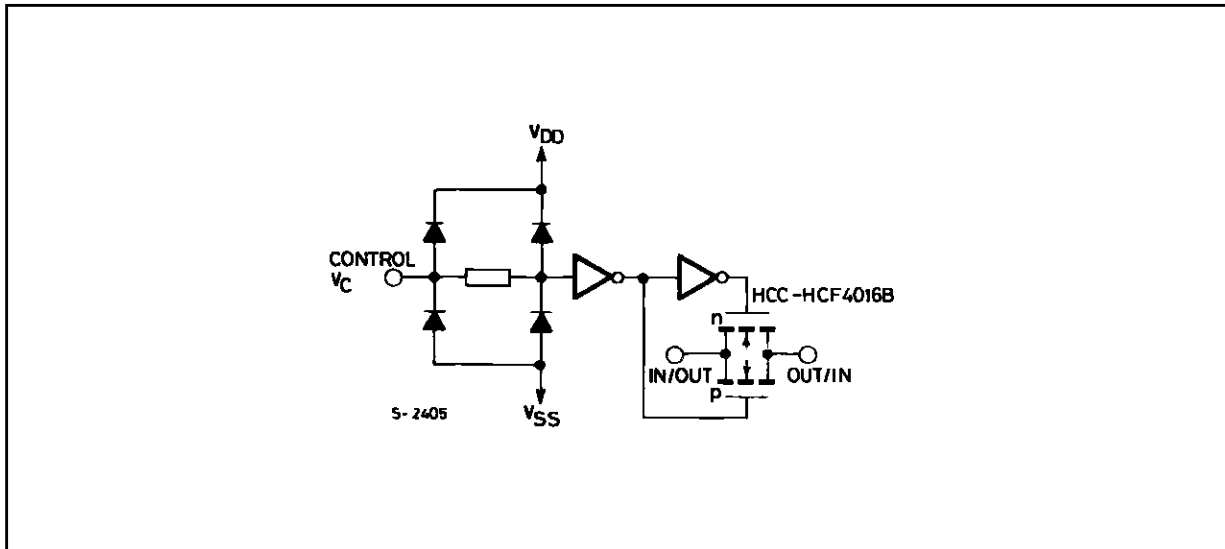

STATIC ELECTRICAL CHARACTERISTICS (over recommended operating conditions)

Symbol	Parameter		Test Conditions			Value						Unit		
			V _C = V _{SS} V _{DD} (V)	V _{DD} (V)	T _{Low} *		25°C			T _{High} *				
					Min.	Max.	Min.	Typ.	Max.	Min.	Max.			
I _L	Quiescent Device Current (all switches on or all switches off)	HCC Types			5	0.25		0.01	0.25		7.5	μA		
					10	0.5		0.01	0.5		15			
					15	1		0.01	1		30			
					20	5		0.02	5		150			
		HCF Types			5	1		0.01	1		7.5			
					10	2		0.01	2		15			
					15	4		0.01	4		30			
SWITCH					V _{IS}									
R _{ON}	Resistance	HCC	R _L = 10kΩ•	+ 7.5 - 7.5	± 0.25	+ 7.5	360		200	400		600	Ω	
						- 7.5	360		200	400		600		
							775		280	850		1230		
		HCF				+ 7.5		370		200	400			520
						- 7.5		370		200	400			520
								790		280	850			1080
HCC	R _L = 10kΩ•	+ 5 - 5	± 0.25	+ 5		600		250	660		960	Ω		
				- 5		600		250	660		960			
						1870		580	2000		2600			
HCF				+ 5		610		250	660		840			
				- 5		610		250	660		840			
						1900		580	2000		2380			

* T_{Low}= - 55°C for HCC device : - 40°C for HCF device.

* T_{High}= + 125°C for HCC device : + 85°C for HCF device.

STATIC ELECTRICAL CHARACTERISTICS (continued)

Symbol	Parameter	Test Conditions				Value						Unit			
			V _C = V _{DD}	V _{SS} (V)	V _{DD} (V)	T _{Low} *		25°C			T _{High} *				
						Min.	Max.	Min.	Typ.	Max.	Min.		Max.		
SWITCH (continued)															
R _{ON}	Resistance	HCC	R _L = 10kΩ•	+ 15	0	+ 15 + 0.25 + 9.3		360 360 775		200 200 300	400 400 850		600 600 1230	Ω	
				HCF	+ 15	0	+ 15 + 0.25 + 9.3		370 370 790		200 200 300	400 400 800			520 520 1080
		HCC	R _L = 10kΩ•	+ 10	0	+ 10 + 0.25 + 5.6		600 600 1870		250 250 560	660 660 2000		960 960 2600		
				HCF	+ 10	0	+ 10 + 0.25 + 5.6		610 610 1900		250 250 560	660 660 2000			840 840 2380
ΔON	Resistance ΔRON (between any 2 of 4 switches)	R _L = 10kΩ•	+ 7.5	- 7.5	± 7.5				10				Ω		
			+ 5	- 5	± 5				15						
Input or Output Leakage Current Switch OFF (effective off resistance)		HCC	V _{DD}	V _C = V _{SS}				± 0.1	10 ⁻⁵	± 0.1		1	μA		
		HCF	V _{DD}	V _C = V _{SS}				± 0.3	10 ⁻⁵	± 0.3		1			
C _I	Input Capacitance	V _{CC} = V _{SS} = - 5				+ 5				4			pF		
C _O	Output Capacitance									4					
C _{IO}	Feedthrough									0.2					
CONTROL (V_C)															
V _{TH}	Switch Threshold Voltage	I _{IS} = 10μA				5	1		1	2.25		1		V	
						10	2		2	4.5		2			
						15	2		2	6.75		2			
I _I	Input Current	HCC Types	V _{IS} ≤ V _{DD}						± 0.1		± 10 ⁻⁵	± 0.1		± 1	μA
		HCF Types							± 0.3		± 10 ⁻⁵	± 0.3		± 1	
C _I	Input Capacitance									5	7.5		pF		

* T_{Low} = - 55°C for HCC device : - 40°C for HCF device.

* T_{High} = + 125°C for HCC device : + 85°C for HCF device.

DYNAMIC ELECTRICAL CHARACTERISTICS ($T_{amb} = 25^{\circ}\text{C}$, $C_L = 50\text{pF}$ all input square wave rise and fall time = 20ns)

Parameter	Test Conditions							Value		Unit
	V_C (V)	R_L (k Ω)	f_i (KHz)	V_I (V)	V_{SS} (V)	V_{DD} (V)	Typ.	Max.		
SWITCH										
t_{pd} Propagation Delay Time (signal input to output)	$= V_{DD}$	10		10sq. Wave	GND	5 10 15	40 20 15	100 50 40		ns
Crosstalk Between any 2 of 4 Switches (f @ - 50dB) $20 \log 10 \frac{V_{O(B)}}{V_{I(A)}} = - 50\text{dB}$	$V_{C(A)} = V_{DD} = + 5$ $V_{C(B)} = V_{SS} = - 5$	1		$V_{I(A)} \Delta = 5\text{p-p}$			0.9			MHz
Frequency Response Switch "ON" (sine wave input) At $20 \log 10 \frac{V_O}{V_I} = - 3\text{dB}$	$= V_{DD}$ $= + 5$	1		5p-p	- 5		40			MHz
Feedthrough (switch OFF) At $20 \log 10 \frac{V_O}{V_I} = - 50\text{dB}$	$= V_{SS}$ $= - 5$	1		- 5p-p		5	1.25			MHz
Sine Wave Distortion	$= V_{DD}$ $= 5$	10	1	5p-p	- 5		0.4			%
CONTROL (V_C)										
Propagation Delay : (turn on control to output)	$V_{DD} - V_{SS}$ (sq. wave)	1		V_{DD} or V_{SS}		5 10 15	$V_{DD}-V_{SS} = 10\text{V}$	35 20 15	70 40 30	ns
Max. Allowable Control Input Repetition Rate	10 (sq. wave)	1		V_{DD}	GND	10		10		MHz
Crosstalk (control input to signal output)	10 (sq. wave)	10			GND	10		50		mV

(Δ) Symmetrical about OV

(\bullet) For all test conditions.

Typical "ON" Characteristics for 1 of 4 switches with $V_{DD} = + 15\text{V}$, $V_{SS} = 0\text{V}$, and Test Circuit.

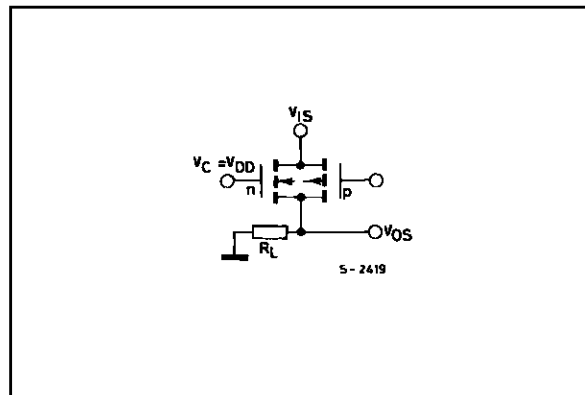
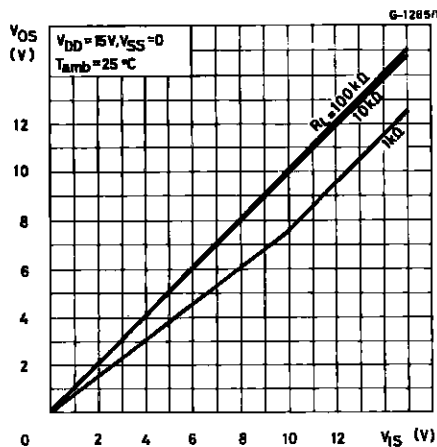

HCC/HCF4016B

Typical "ON" Characteristics for 1 of 4 switches with $V_{DD} = +10V$, $V_{SS} = 0V$, and Test Circuit.

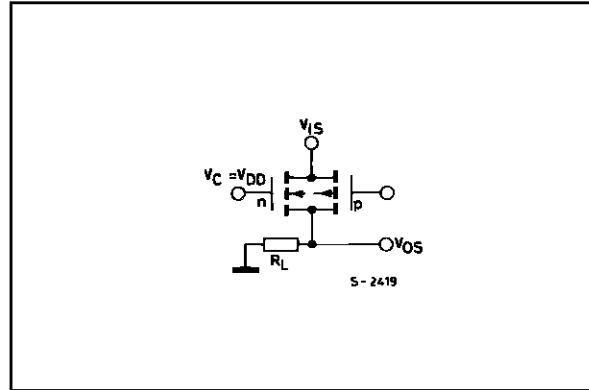
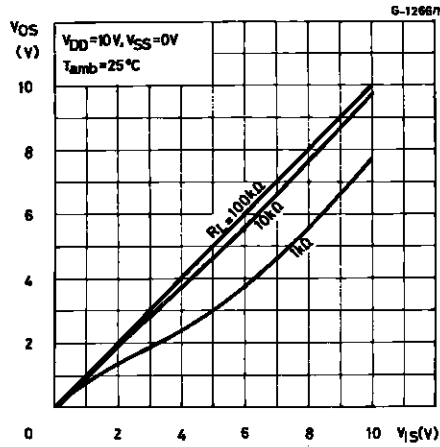

Typical "ON" Characteristics for 1 of 4 switches with $V_{DD} = +5V$, $V_{SS} = 0V$, and Test Circuit.

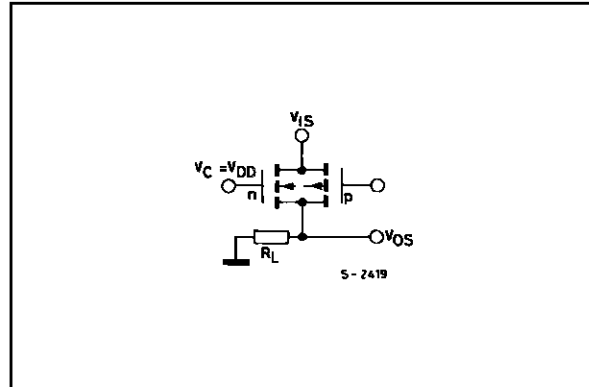
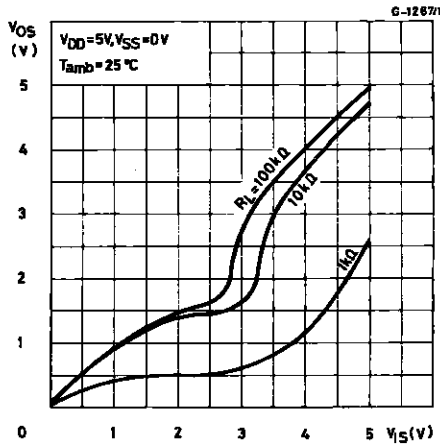

Typical "ON" Characteristics for 1 of 4 switches with $V_{DD} = +7.5V$, $V_{SS} = -7.5V$, and Test Circuit.

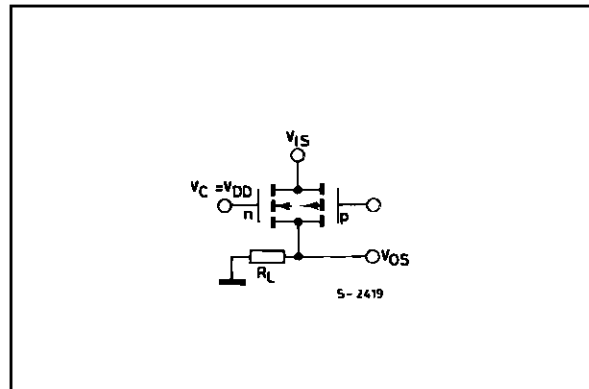
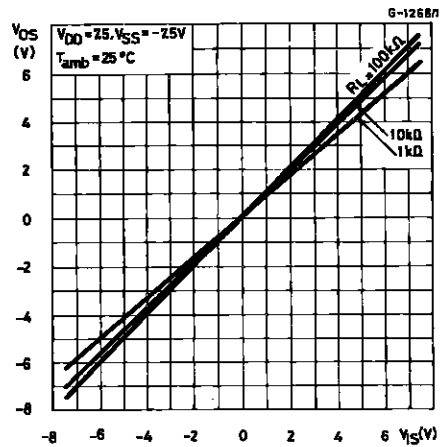

Typical "ON" Characteristics for 1 of 4 switches with $V_{DD} = +5V$, $V_{SS} = -5V$, and Test Circuit.

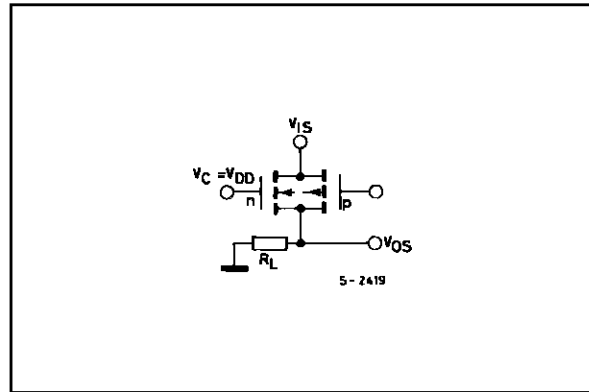
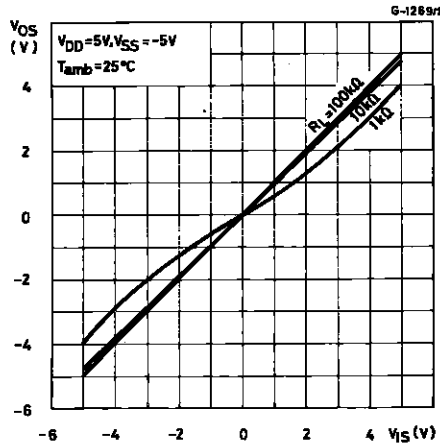

Typical "ON" Characteristics for 1 of 4 switches with $V_{DD} = +2.5V$, $V_{SS} = -2.5V$, and Test Circuit.

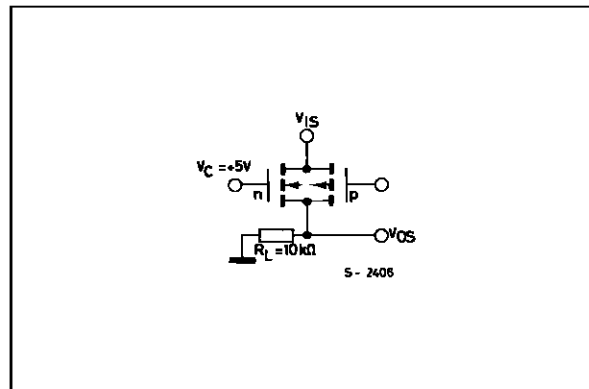
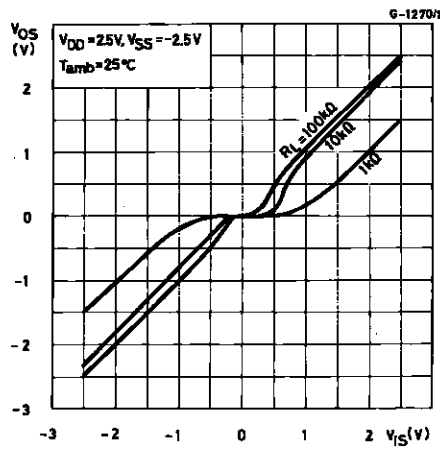

Typical "ON" Characteristics as function of temp. for 1 of 4 switches with $V_{DD} = +5V$ and Test Circuit.

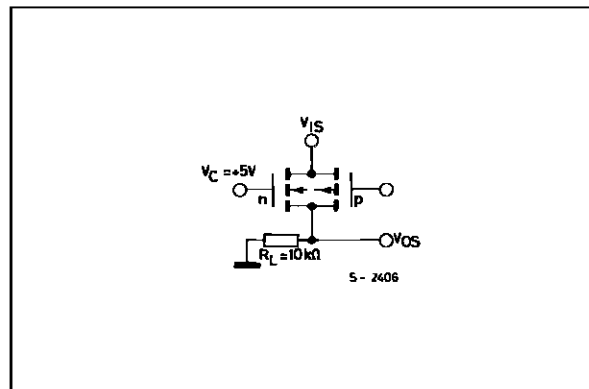
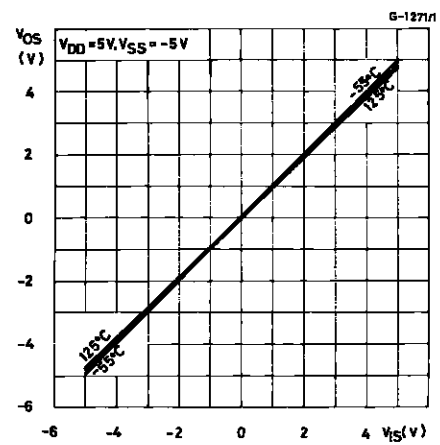

HCC/HCF4016B

Typical feedthru vs. frequency-switch "OFF" and Test Circuit.

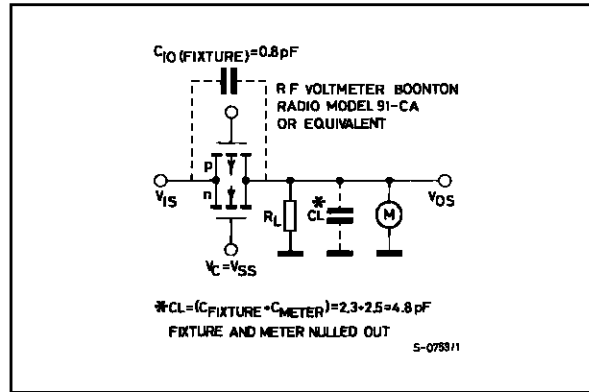
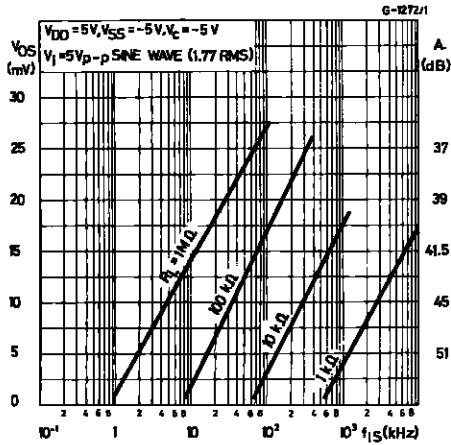

Typical Crosstalk between Switch Circuits in the Same Package.

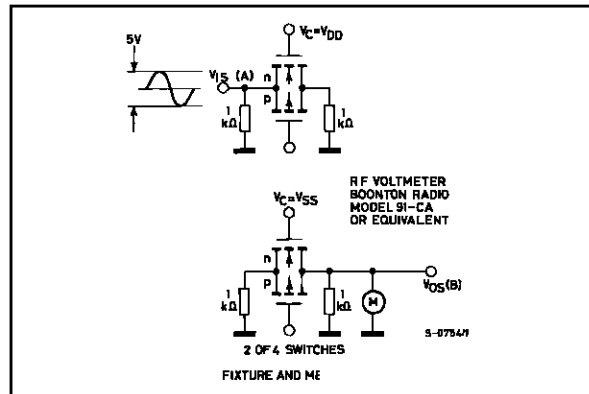
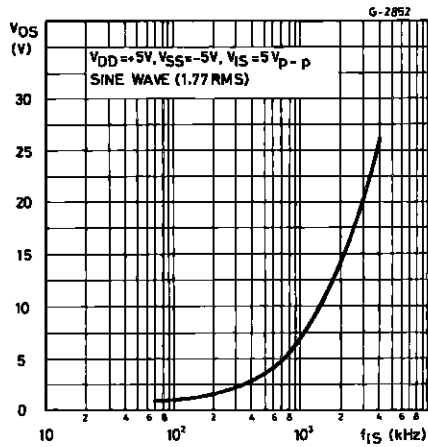

Typical Switch Frequency response-switch "ON" and Test Circuit.

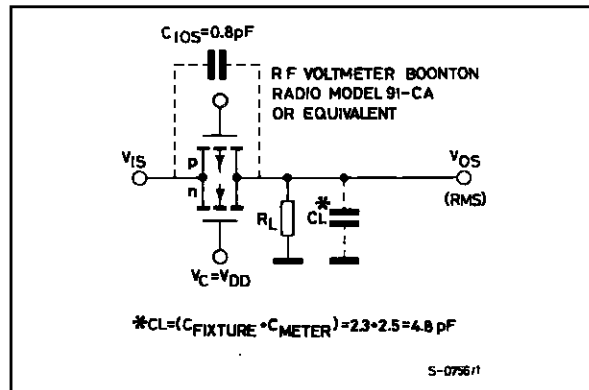
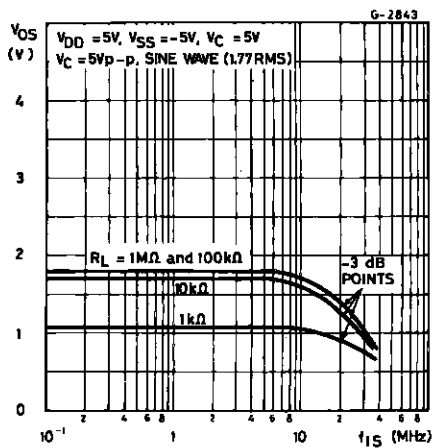

TYPICAL "ON" RESISTANCE CHARACTERISTICS, $T_{amb} = 25^{\circ}\text{C}$

Characteristic*	Supply Conditions		Load Conditions					
			$R_L = 1\text{ k}\Omega$		$R_L = 10\text{ k}\Omega$		$R_L = 100\text{ k}\Omega$	
	V_{DD} (V)	V_{SS} (V)	Value (Ω)	V_{is} (V)	Value (Ω)	V_{is} (V)	Value (Ω)	V_{is} (V)
R_{ON}	+ 15	0	200	+ 15	200	+ 15	180	+ 15
			200	0	200	0	200	0
$R_{ON} \text{ (max)}$	+ 15	0	300	+ 11	300	+ 9.3	320	+ 9.2
R_{ON}	+ 10	0	290	+ 10	250	+ 10	240	+ 10
			290	0	250	0	300	0
$R_{ON} \text{ (max)}$	+ 10	0	500	+ 7.4	560	+ 5.6	610	+5.5
R_{ON}	+ 5	0	860	+ 5	470	+ 5	450	+ 5
			600	0	580	0	800	0
$R_{ON} \text{ (max)}$	+ 5	0	1.7k	+ 4.2	7k	+ 2.9	33k	+2.7
R_{ON}	+ 2.5	- 2.5	590	+ 2.5	450	+ 2.5	490	+ 2.5
			720	- 2.5	520	- 2.5	520	- 2.5
$R_{ON} \text{ (max)}$	+ 2.5	- 2.5	232k	± 0.25	300k	± 0.25	870k	± 0.25

* Variation from a perfect switch, $R_{ON} = 0\Omega$.

TEST CIRCUITS

"OFF" Switch Input or Put Leakage Current.

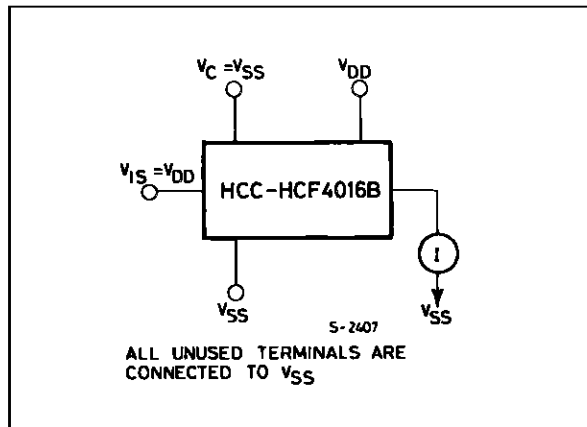

Square-Wave Response.

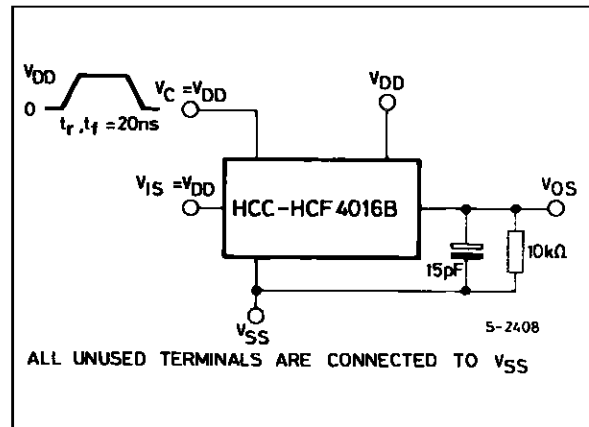

HCC/HCF4016B

TEST CIRCUITS (continued)

Crosstalk-control Input to Signal Output.

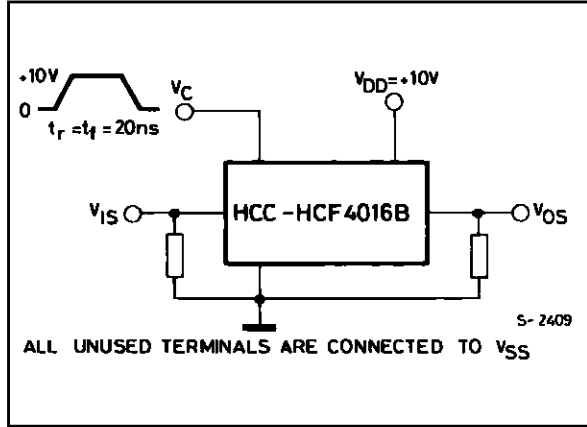

Propagaton Delay Time Signal Input (VIs) to Signal Output (VOS).

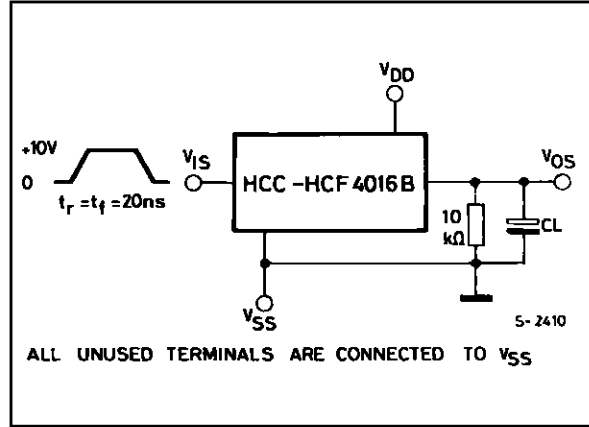

Max Allowable Control-input Repetition Rate.

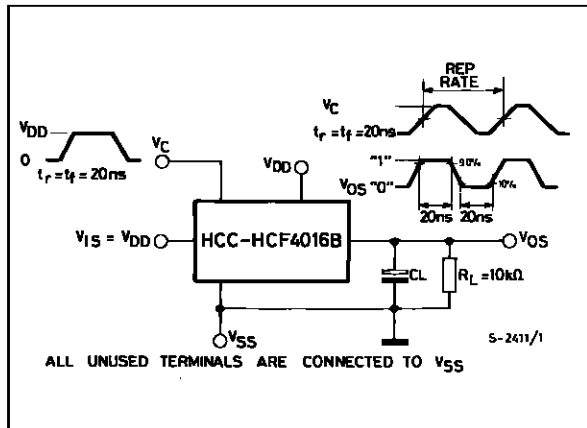

Switch Treshold Voltage.

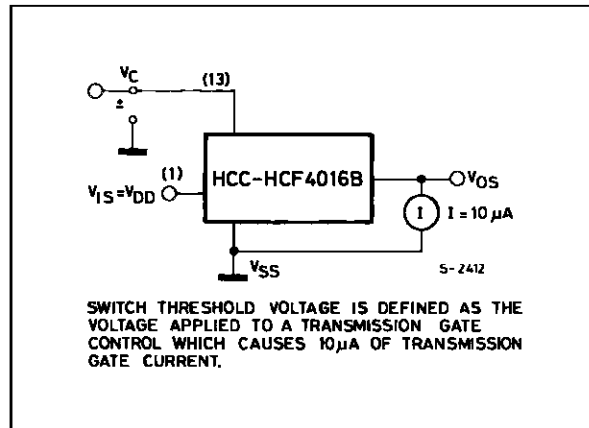

Capacitance Cios and Cos.

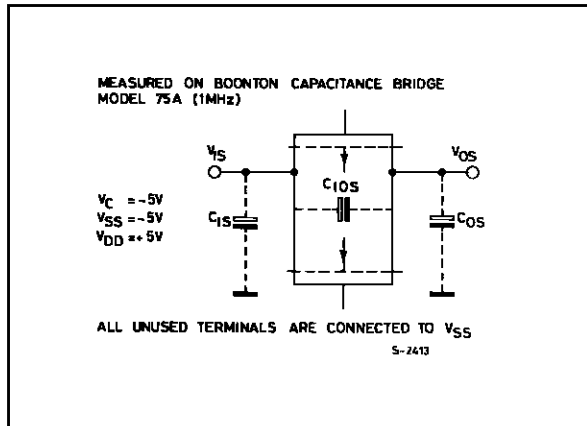

Turn-On Propagation Delay-control Input to Output.

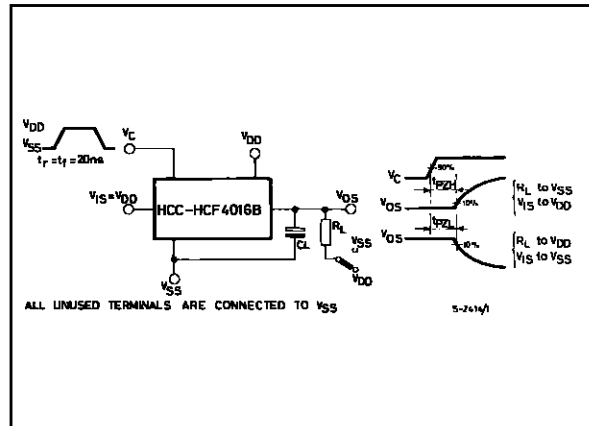

Plastic DIP14 MECHANICAL DATA

DIM.	mm			inch		
	MIN.	TYP.	MAX.	MIN.	TYP.	MAX.
a1	0.51			0.020		
B	1.39		1.65	0.055		0.065
b		0.5			0.020	
b1		0.25			0.010	
D			20			0.787
E		8.5			0.335	
e		2.54			0.100	
e3		15.24			0.600	
F			7.1			0.280
I			5.1			0.201
L		3.3			0.130	
Z	1.27		2.54	0.050		0.100

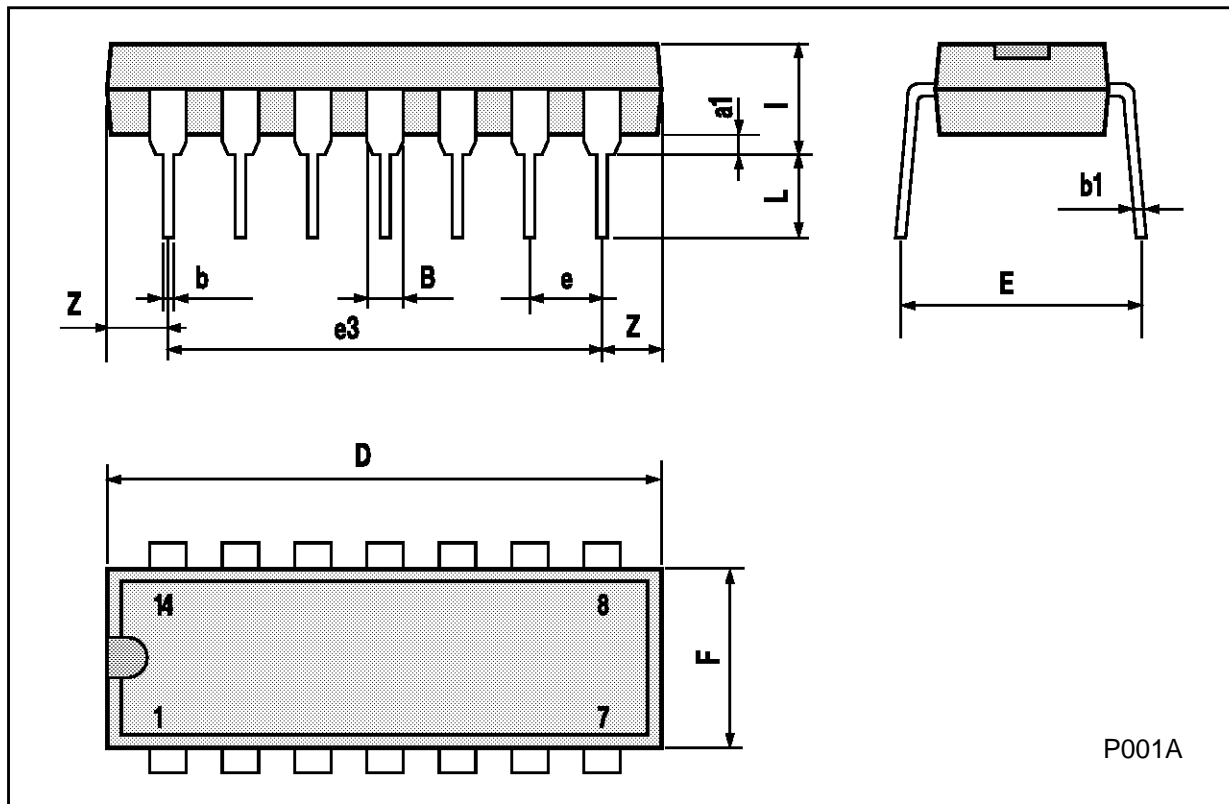

Ceramic DIP14/1 MECHANICAL DATA

DIM.	mm			inch		
	MIN.	TYP.	MAX.	MIN.	TYP.	MAX.
A			20			0.787
B			7.0			0.276
D		3.3			0.130	
E	0.38			0.015		
e3		15.24			0.600	
F	2.29		2.79	0.090		0.110
G	0.4		0.55	0.016		0.022
H	1.17		1.52	0.046		0.060
L	0.22		0.31	0.009		0.012
M	1.52		2.54	0.060		0.100
N			10.3			0.406
P	7.8		8.05	0.307		0.317
Q			5.08			0.200

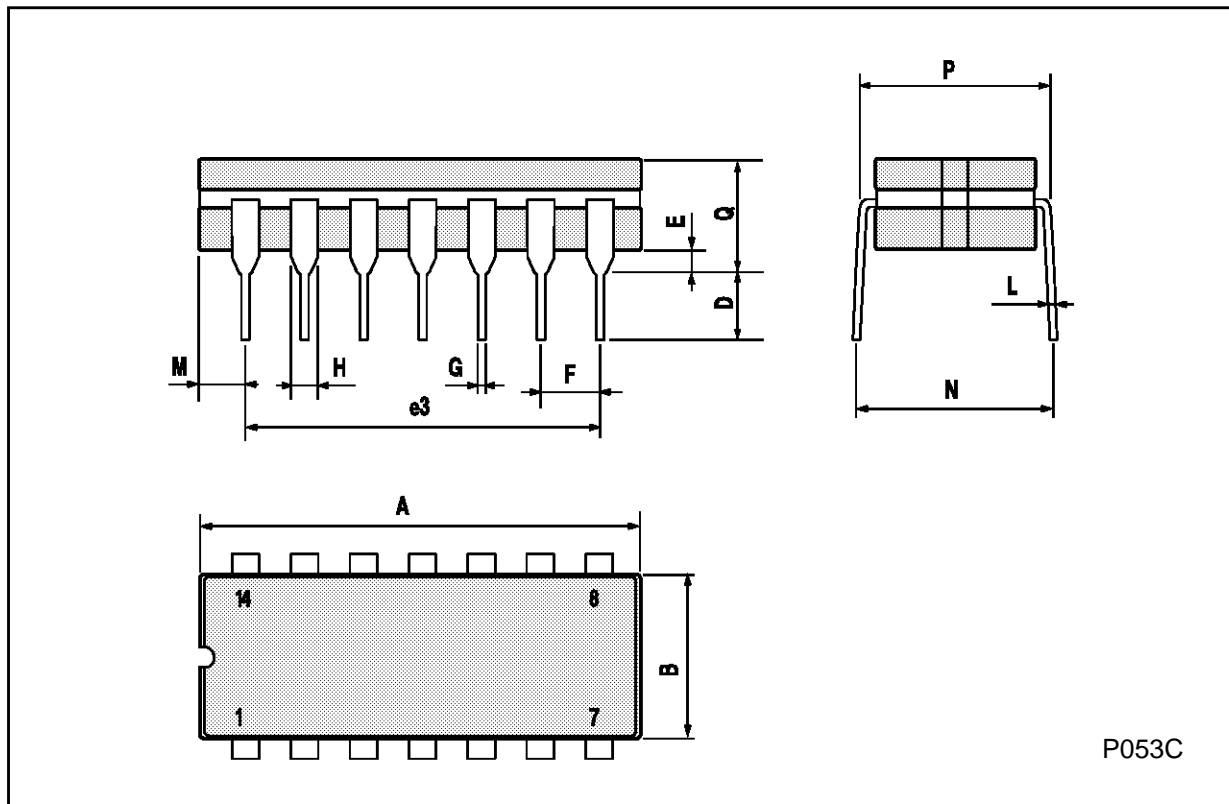

P053C

SO14 MECHANICAL DATA

DIM.	mm			inch		
	MIN.	TYP.	MAX.	MIN.	TYP.	MAX.
A			1.75			0.068
a1	0.1		0.2	0.003		0.007
a2			1.65			0.064
b	0.35		0.46	0.013		0.018
b1	0.19		0.25	0.007		0.010
C		0.5			0.019	
c1	45° (typ.)					
D	8.55		8.75	0.336		0.344
E	5.8		6.2	0.228		0.244
e		1.27			0.050	
e3		7.62			0.300	
F	3.8		4.0	0.149		0.157
G	4.6		5.3	0.181		0.208
L	0.5		1.27	0.019		0.050
M			0.68			0.026
S	8° (max.)					

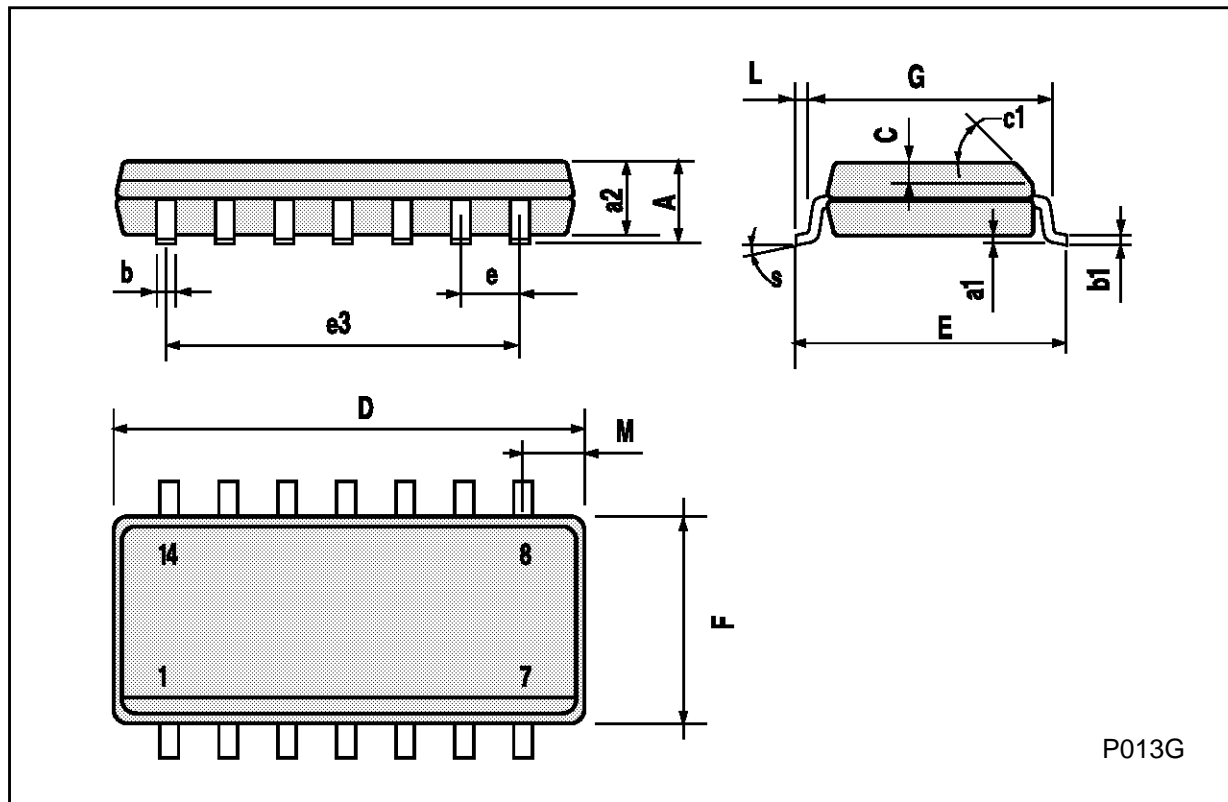

PLCC20 MECHANICAL DATA

DIM.	mm			inch		
	MIN.	TYP.	MAX.	MIN.	TYP.	MAX.
A	9.78		10.03	0.385		0.395
B	8.89		9.04	0.350		0.356
D	4.2		4.57	0.165		0.180
d1		2.54			0.100	
d2		0.56			0.022	
E	7.37		8.38	0.290		0.330
e		1.27			0.050	
e3		5.08			0.200	
F		0.38			0.015	
G			0.101			0.004
M		1.27			0.050	
M1		1.14			0.045	

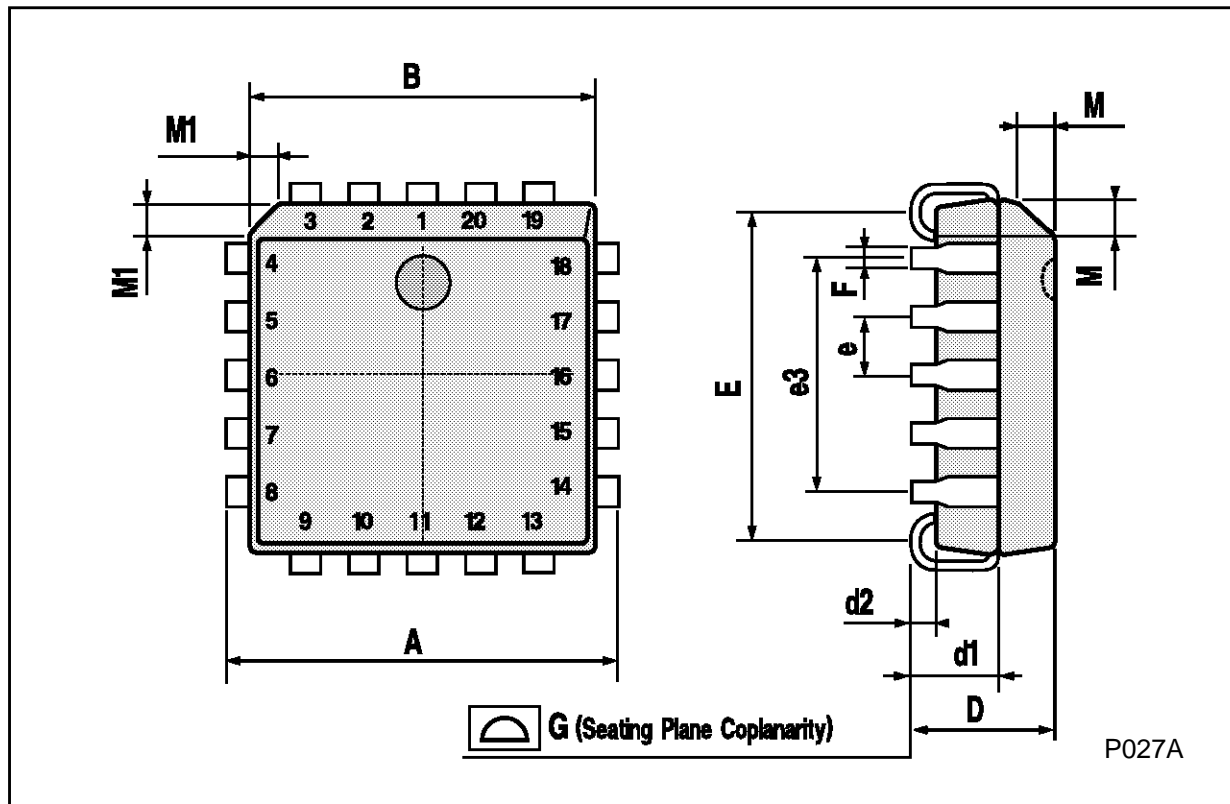

Information furnished is believed to be accurate and reliable. However, SGS-THOMSON Microelectronics assumes no responsibility for the consequences of use of such information nor for any infringement of patents or other rights of third parties which may result from its use. No license is granted by implication or otherwise under any patent or patent rights of SGS-THOMSON Microelectronics. Specifications mentioned in this publication are subject to change without notice. This publication supersedes and replaces all information previously supplied. SGS-THOMSON Microelectronics products are not authorized for use as critical components in life support devices or systems without express written approval of SGS-THOMSON Microelectronics.

© 1994 SGS-THOMSON Microelectronics - All Rights Reserved

SGS-THOMSON Microelectronics GROUP OF COMPANIES

Australia - Brazil - France - Germany - Hong Kong - Italy - Japan - Korea - Malaysia - Malta - Morocco - The Netherlands -
Singapore - Spain - Sweden - Switzerland - Taiwan - Thailand - United Kingdom - U.S.A