

HEX BUFFER/CONVERTERS

4049UB INVERTING TYPE
4050B NON-INVERTING TYPE

- HIGH SINK CURRENT FOR DRIVING 2 TTL LOADS
- HIGH-TO-LOW LEVEL LOGIC CONVERSION
- QUIESCENT CURRENT SPECIFIED TO 20V FOR HCC DEVICE
- HIGH "SINK" AND "SOURCE" CURRENT CAPABILITY
- 5V, 10V AND 15V PARAMETRIC RATINGS
- INPUT CURRENT OF 100 nA AT 18V AND 25°C FOR HCC DEVICE
- 100% TESTED FOR QUIESCENT CURRENT
- MEETS ALL REQUIREMENTS OF JEDEC TENTATIVE STANDARD N^o. 13A, "STANDARD SPECIFICATIONS FOR DESCRIPTION OF "B" SERIES CMOS DEVICES"

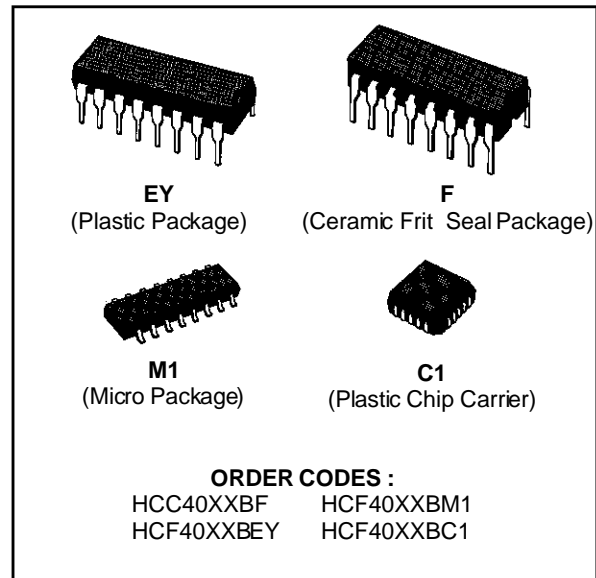

DESCRIPTION

The **HCC4049UB/4050B** (extended temperature range) and the **HCF4049UB/4050B** (intermediate temperature range) are monolithic integrated circuits available in 16-lead dual in-line plastic or ceramic package and plastic micro package.

The **HCC/HCF4049UB/4050B** are inverting and non-inverting hex buffers, respectively, and feature logic-level conversion using only one supply voltage (V_{DD}). The input-signal high level (V_{IH}) can exceed the V_{DD} supply voltage when these devices are used for logic level conversions. These devices are intended for use as COS/MOS to DTL/TTL converters and can drive directly two DTL/TTL loads ($V_{DD} = 5V$, $V_{OL} \leq 0.4V$, and $I_{OL} \geq 3.2mA$).

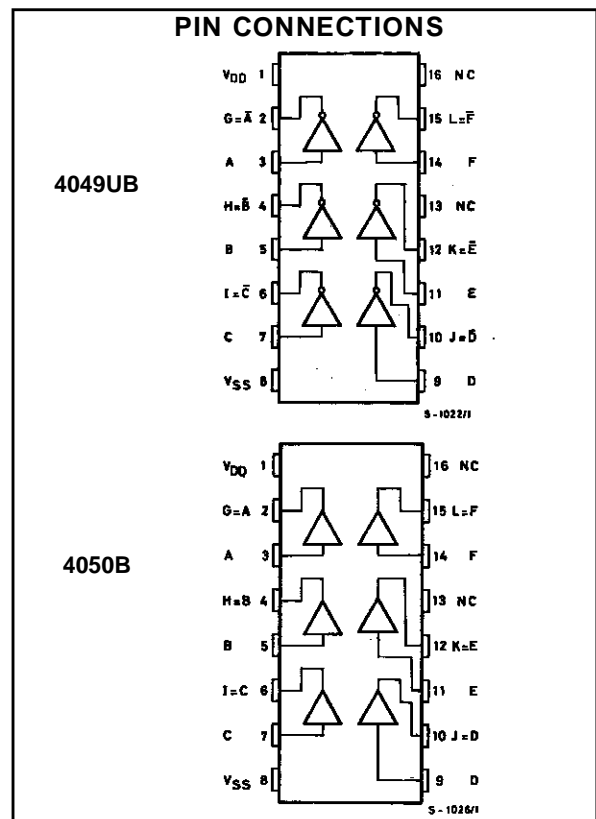

HCC/HCF4049UB/4050B

SCHEMATIC DIAGRAMS (1 of 6 identical units)

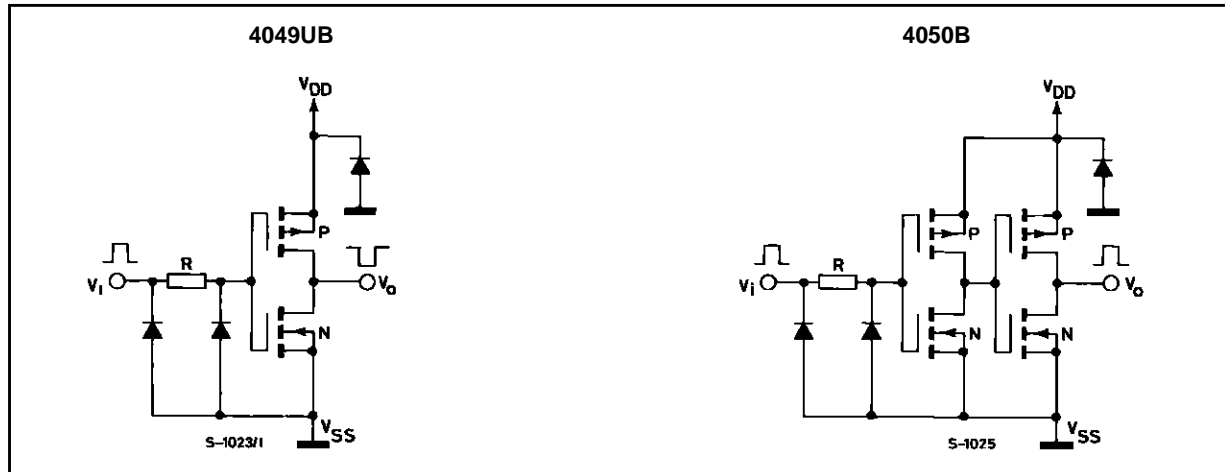

ABSOLUTE MAXIMUM RATINGS

Symbol	Parameter	Value	Unit
V_{DD}^*	Supply Voltage : HCC Types HCF Types	- 0.5 to + 20 - 0.5 to + 18	V V
V_i	Input Voltage	- 0.5 to $V_{DD} + 0.5$	V
I_I	DC Input Current (any one input)	± 10	mA
P_{tot}	Total Power Dissipation (per package) Dissipation per Output Transistor for $T_{op} =$ Full Package-temperature Range	200 100	mW mW
T_{op}	Operating Temperature : HCC Types HCF Types	- 55 to + 125 - 40 to + 85	$^{\circ}\text{C}$ $^{\circ}\text{C}$
T_{stg}	Storage Temperature	- 65 to + 150	$^{\circ}\text{C}$

Stresses above those listed under "Absolute Maximum Ratings" may cause permanent damage to the device. This is a stress rating only and functional operation of the device at these or any other conditions above those indicated in the operational sections of this specification is not implied. Exposure to absolute maximum rating conditions for external periods may affect device reliability.

* All voltage values are referred to V_{SS} pin voltage.

RECOMMENDED OPERATING CONDITIONS

Symbol	Parameter	Value	Unit
V_{DD}	Supply Voltage : HCC Types HCF Types	3 to 18 3 to 15	V V
V_i	Input Voltage	0 to V_{DD}	V
T_{op}	Operating Temperature : HCC Types HCF Types	- 55 to + 125 - 40 to + 85	$^{\circ}\text{C}$ $^{\circ}\text{C}$

STATIC ELECTRICAL CHARACTERISTICS (over recommended operating conditions)

Symbol	Parameter		Test Conditions			Value						Unit	
			V _I (V)	V _O (V)	V _{DD} (V)	T _{Low} *		25°C			T _{High} *		
						Min.	Max.	Min.	Typ.	Max.	Min.		Max.
I _L	Quiescent Supply Current	HCC Types	0/ 5		5		1		0.02	1		30	μA
			0/10		10		2		0.02	2		60	
			0/15		15		4		0.02	4		120	
		0/20		20		20		0.04	20		600		
		HCF Types	0/ 5		5		4		0.02	4		30	
			0/10		10		8		0.02	8		60	
0/15			15		16		0.02	16		120			
V _{OH}	Output High Voltage		0/ 5		5	4.95		4.95			4.95	V	
			0/10		10	9.95		9.95			9.95		
			0/15		15	14.95		14.95			14.95		
V _{OL}	Output Low Voltage		5/0		5		0.05			0.05	0.05	V	
			10/0		10		0.05			0.05	0.05		
			15/0		15		0.05			0.05	0.05		
V _{IH}	Input High Voltage (4049UB)			0.5	5	4		4			4	V	
				1	10	8		8			8		
				2	15	12		12			12		
V _{IH}	Input High Voltage (4050B)			4.5	5	3.5		3.5			3.5	V	
				9	10	7		7			7		
				13.5	16	11		11			11		
V _{IL}	Input Low Voltage (4049UB)			4.5	5		1			1	1	V	
				9	10		2			2	2		
				13	15		3			3	3		
V _{IL}	Input Low Voltage (4050B)			0.5	5		1.5			1.5	1.5	V	
				1	10		3			3	3		
				1.5	15		4			4	4		
I _{OH}	Output Drive Current	HCC Types	0/ 5	2.5	5	1.6		-1.25	- 6.4		- 0.9	mA	
			0/ 5	4.6	5	0.64		-0.51	- 1.6		-0.36		
			0/10	9.5	10	1.6		-1.30	- 3.6		- 0.9		
		0/15	13.5	15	4.7		-3.75	- 12		- 2.7			
		HCF Types	0/ 5	2.5	5	1.5		-1.25	- 6.4		- 1		
			0/ 5	4.6	5	0.61		-0.51	- 1.6		-0.42		
0/10	9.5		10	1.5		-1.25	- 3.6		- 1				
I _{OL}	Output Sink Current	HCC Types	0/ 5	0.4	5	3.75		3.2	6.4		2.2	mA	
			0/10	0.5	10	10		8	16		5.6		
			0/15	1.5	15	30		24	48		17		
		HCF Types	0/ 5	0.4	5	3.6		3.2	6.4		2.6		
			0/10	0.5	10	9.6		8	16		6.6		
			0/15	1.5	15	28		24	48		19		
I _{IH} , I _{IL}	Input Leakage Current	HCC Types	0/18		18		± 0.1		±10 ⁻⁵	± 0.1		± 1	
		HCF Types	0/15		15		± 0.3		±10 ⁻⁵	± 0.3		± 1	
C _I	Input Capacitance	4049UB 4050B	Any Input						15 5	22.5 7.5		pF	

(*) T_{Low} = - 55°C for HCC device ; - 40°C for HCF device.

T_{High} = + 125°C for HCC device ; + 85°C for HCF device.

The Noise Margin (only HCC/HCF4050B type) for both "1" and "0" level is : 1V min. with V_{DD} = 5V, 2V min. with V_{DD} = 10V, 2.5V min. with V_{DD} = 15V.

HCC/HCF4049UB/4050B

DYNAMIC ELECTRICAL CHARACTERISTICS ($T_{amb} = 25^{\circ}\text{C}$, $C_L = 50\text{pF}$, $R_L = 200\text{k}\Omega$, typical temperature coefficient for all V_{DD} values is $0.3\%/^{\circ}\text{C}$, all input rise and fall times = 20ns)

Symbol	Parameter	Test Conditions		Value			Unit
		V_I (V)	V_{DD} (V)	Min.	Typ.	Max.	
t_{PLH}	Propagation Delay Time (4049UB)	5	5		60	120	ns
		10	10		32	65	
		10	5		45	90	
		15	15		25	50	
		15	5		45	90	
t_{PLH}	Propagation Delay Time (4050B)	5	5		70	140	ns
		10	10		40	80	
		10	5		45	90	
		15	15		30	60	
		15	5		40	80	
t_{PHL}	Propagation delay Time (4049UB)	5	5		32	65	ns
		10	10		20	40	
		10	5		15	30	
		15	15		15	30	
		15	5		10	20	
t_{PHL}	Propagation Delay Time (4050B)	5	5		55	110	ns
		10	10		22	55	
		10	5		50	100	
		15	15		15	30	
		15	5		50	100	
t_{TLH}	Transition Time	5	5		80	160	ns
		10	10		40	80	
		15	15		30	60	
t_{THL}	Transition Time	5	5		30	60	ns
		10	10		20	40	
		15	15		15	30	

Minimum and Maximum Voltage Transfer Characteristics for 4049UB.

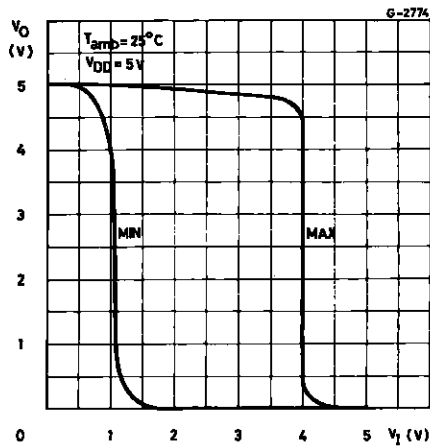

Minimum and Maximum Voltage Transfer Characteristics for 4050B.

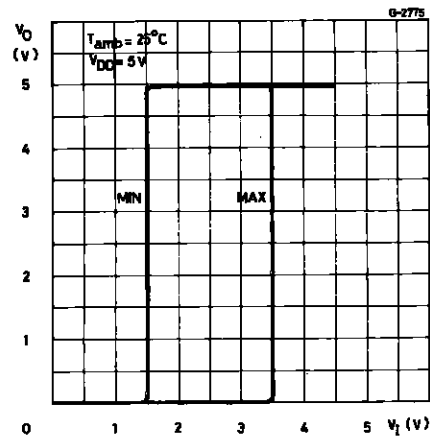

Typical Voltage Transfer Characteristics as a Function of Temperature for 4049UB.

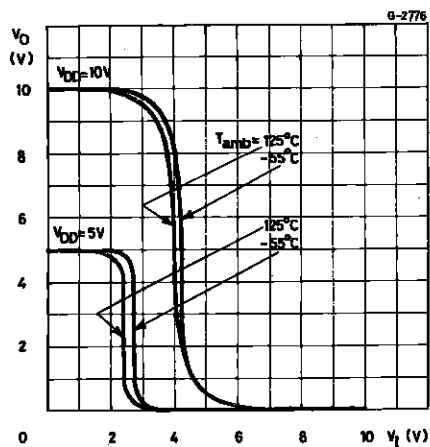

Typical Voltage Transfer Characteristics as a Function of Temperature for 4050B.

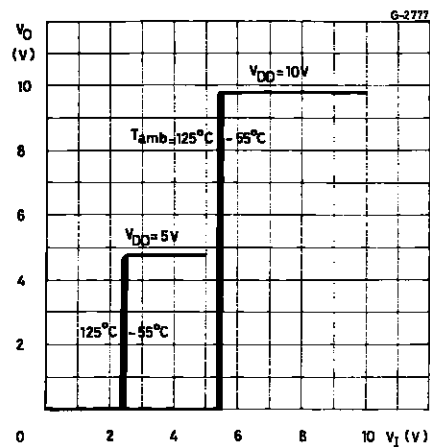

Typical Output Low (sink) Current Characteristics.

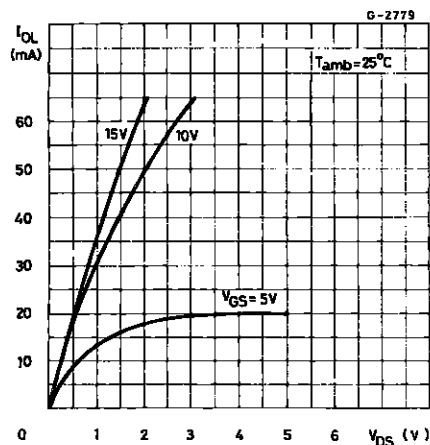

Minimum Output Low (sink) Current Characteristics.

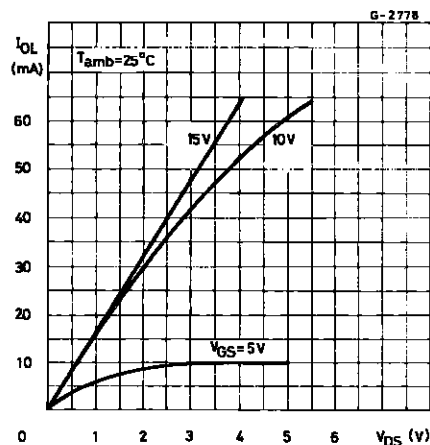

HCC/HCF4049UB/4050B

Typical Output High (source) Current Characteristics.

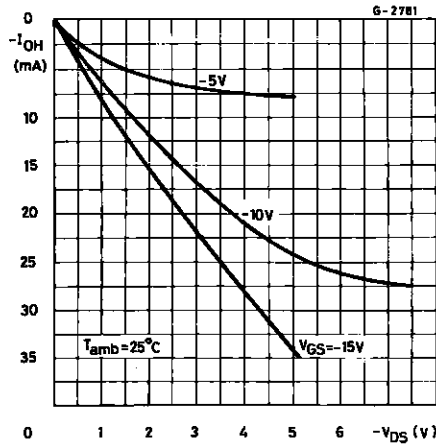

Minimum Output High (source) Current Characteristics.

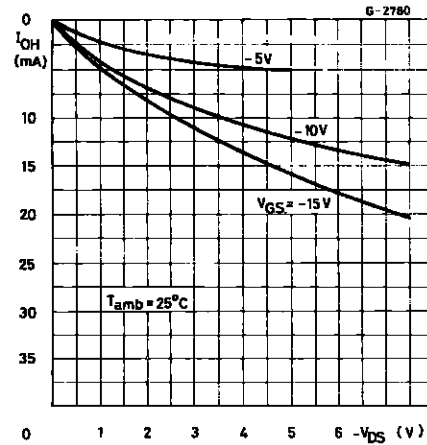

Typical Power Dissipation per Buffer/Inverter vs. Frequency.

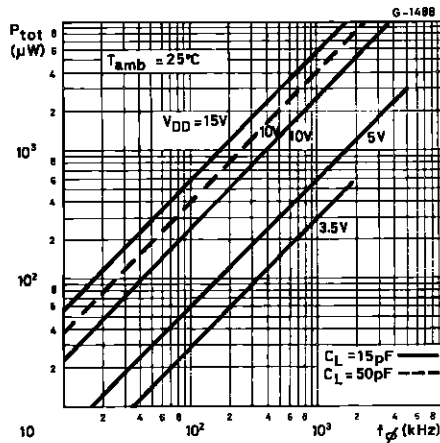

Typical Power Dissipation vs. Input Transition Time per Inverter for 4049UB.

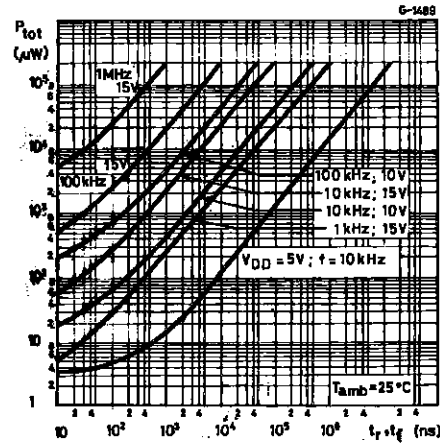

Typical Power Dissipation vs. Input Transition Time per Inverter for 4050B.

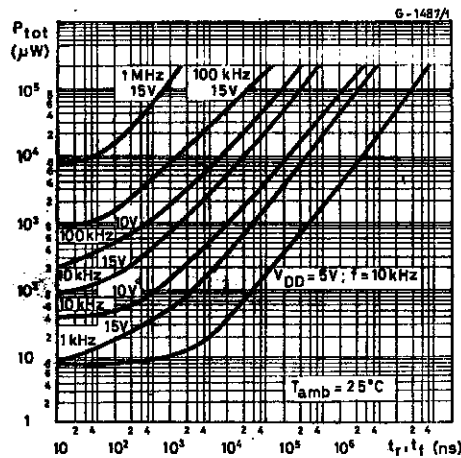

Logic-Level Conversion Application.

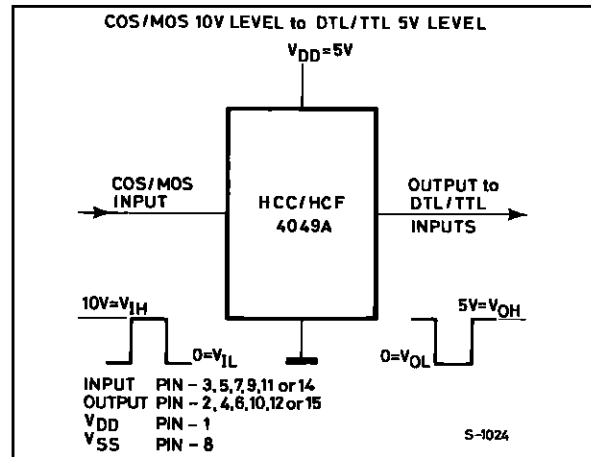

TEST CIRCUITS

Quiescent Device Current.

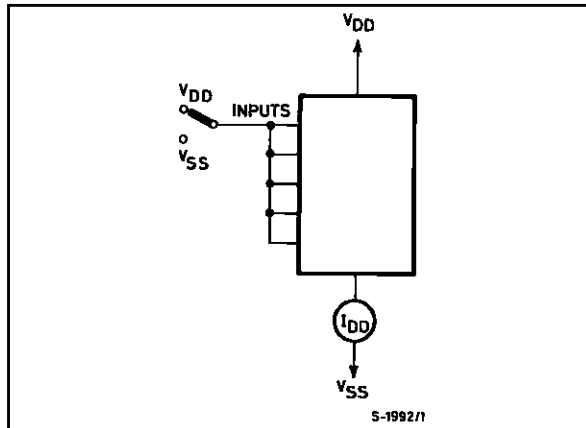

Input Voltage.

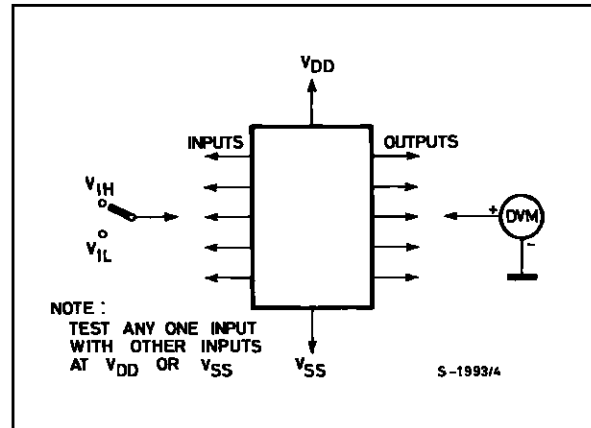

Input Current.

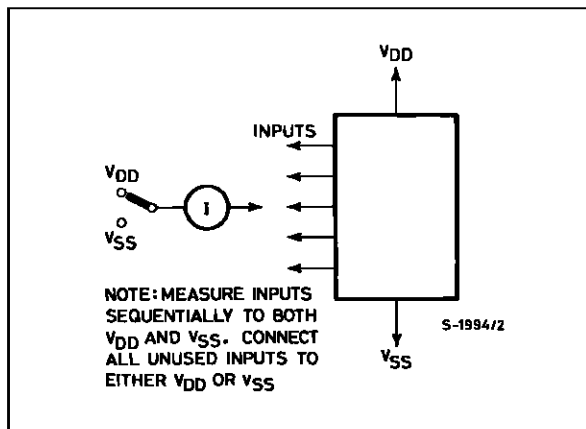

Plastic DIP16 (0.25) MECHANICAL DATA

DIM.	mm			inch		
	MIN.	TYP.	MAX.	MIN.	TYP.	MAX.
a1	0.51			0.020		
B	0.77		1.65	0.030		0.065
b		0.5			0.020	
b1		0.25			0.010	
D			20			0.787
E		8.5			0.335	
e		2.54			0.100	
e3		17.78			0.700	
F			7.1			0.280
l			5.1			0.201
L		3.3			0.130	
Z			1.27			0.050

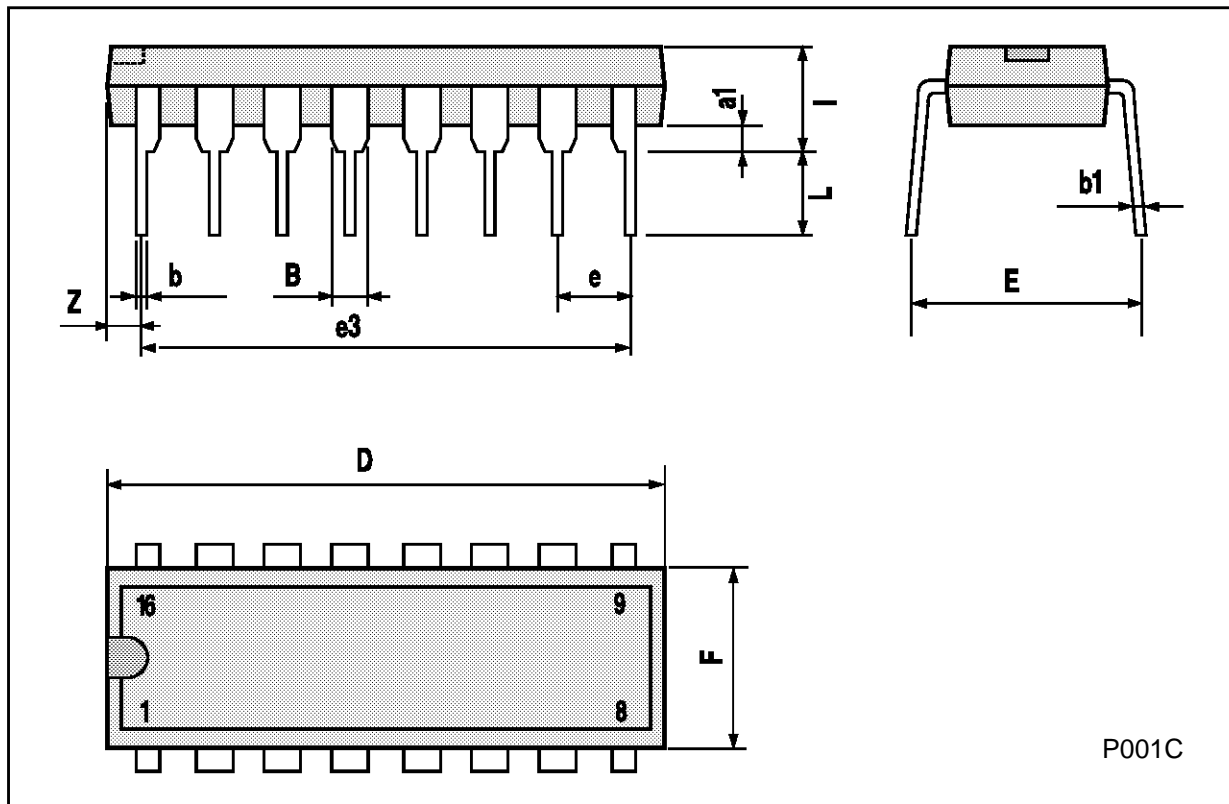

P001C

Ceramic DIP16/1 MECHANICAL DATA

DIM.	mm			inch		
	MIN.	TYP.	MAX.	MIN.	TYP.	MAX.
A			20			0.787
B			7			0.276
D		3.3			0.130	
E	0.38			0.015		
e3		17.78			0.700	
F	2.29		2.79	0.090		0.110
G	0.4		0.55	0.016		0.022
H	1.17		1.52	0.046		0.060
L	0.22		0.31	0.009		0.012
M	0.51		1.27	0.020		0.050
N			10.3			0.406
P	7.8		8.05	0.307		0.317
Q			5.08			0.200



SO16 (Narrow) MECHANICAL DATA

DIM.	mm			inch		
	MIN.	TYP.	MAX.	MIN.	TYP.	MAX.
A			1.75			0.068
a1	0.1		0.2	0.004		0.007
a2			1.65			0.064
b	0.35		0.46	0.013		0.018
b1	0.19		0.25	0.007		0.010
C		0.5			0.019	
c1	45° (typ.)					
D	9.8		10	0.385		0.393
E	5.8		6.2	0.228		0.244
e		1.27			0.050	
e3		8.89			0.350	
F	3.8		4.0	0.149		0.157
G	4.6		5.3	0.181		0.208
L	0.5		1.27	0.019		0.050
M			0.62			0.024
S	8° (max.)					



P013H

PLCC20 MECHANICAL DATA

DIM.	mm			inch		
	MIN.	TYP.	MAX.	MIN.	TYP.	MAX.
A	9.78		10.03	0.385		0.395
B	8.89		9.04	0.350		0.356
D	4.2		4.57	0.165		0.180
d1		2.54			0.100	
d2		0.56			0.022	
E	7.37		8.38	0.290		0.330
e		1.27			0.050	
e3		5.08			0.200	
F		0.38			0.015	
G			0.101			0.004
M		1.27			0.050	
M1		1.14			0.045	

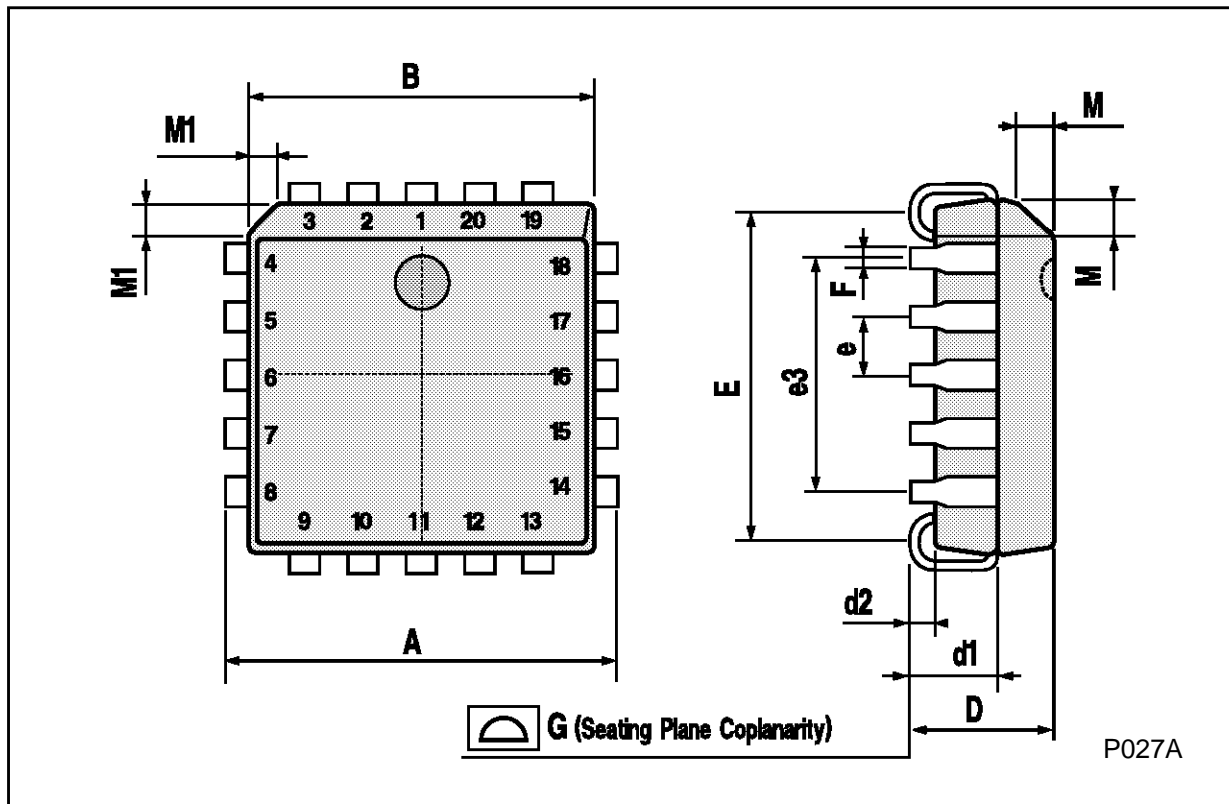

Information furnished is believed to be accurate and reliable. However, SGS-THOMSON Microelectronics assumes no responsibility for the consequences of use of such information nor for any infringement of patents or other rights of third parties which may result from its use. No license is granted by implication or otherwise under any patent or patent rights of SGS-THOMSON Microelectronics. Specifications mentioned in this publication are subject to change without notice. This publication supersedes and replaces all information previously supplied. SGS-THOMSON Microelectronics products are not authorized for use as critical components in life support devices or systems without express written approval of SGS-THOMSON Microelectronics.

© 1994 SGS-THOMSON Microelectronics - All Rights Reserved

SGS-THOMSON Microelectronics GROUP OF COMPANIES
Australia - Brazil - France - Germany - Hong Kong - Italy - Japan - Korea - Malaysia - Malta - Morocco - The Netherlands -
Singapore - Spain - Sweden - Switzerland - Taiwan - Thailand - United Kingdom - U.S.A