

# HD63645/HD64645/HD64646 LCTC (LCD Timing Controller)

## Description

The HD63645/HD64645/HD64646 LCTC is a control LSI for large size dot matrix liquid crystal displays. The LCTC is software compatible with the HD6845 CRTC, since its programming method of internal registers and memory addresses is based on the CRTC. A display system can be easily converted from a CRT to an LCD.

The HD64646 LCTC is a modified version of the HD64645 LCTC with different LCD interface timing.

The LCTC offers a variety of functions and performance features such as vertical and horizontal scrolling, and various types of character attribute functions such as reverse video, blinking, nondisplay (white or black), and an OR function for simple superimposition of character and graphic displays. The LCTC also provides DRAM refresh address output.

A compact LCD system with a large screen can be configured by connecting the LCTC with the HD66204 (column driver) and the HD66205 (common driver) by utilizing 4-bit  $\times$  2 data outputs. Power dissipation has been lowered by adopting the CMOS process.

## Features

- Software compatible with the HD6845 CRTC
- Programmable screen size:
  - Up to 1024 dots (height)
  - Up to 4096 dots (width)
- High-speed data transfer:
  - Up to 20 Mbits/s in character mode
  - Up to 40 Mbits/s in graphic mode
- Selectable single or dual screen configuration
- Programmable multiplexing duty ratio: static to 1/512 duty cycle
- Programmable character font:
  - 1-32 dots (height)
  - 8 dots (width)
- Versatile character attributes: reverse video, blinking, nondisplay (white), nondisplay (black)
- OR function: superimposing characters and graphics display

- Cursor with programmable height, blink rate, display position, and on/off switch
- Vertical Smooth Scrolling and horizontal scrolling by the character
- Versatile display modes programmable by mode register or external pins: display on/off, graphic or character, normal or wide, attributes, and blink enable
- Refresh address output for dynamic RAM
- 4- or 8-bit parallel data transfer between LCTC and LCD driver
- Recommended LCD driver:
  - HD66204, HD66214T and HD66224T (column)
  - HD66205 and HD66215T (common)
  - HD66106F and HD66107T (column/common)
  - HD66110RT (column)
- CPU interface:
  - 68 family HD63645
  - Z80 family HD64645, HD64646
- CMOS process
- Single +5 V  $\pm$ 10%

## Differences Between Products HD63645, HD64645 and HD64646

	HD63645	HD64645	HD64646
CPU Interface	68 family	Z80 family	Z80 family
Bus Timing	2 MHz	4 MHz	4 MHz
Pin Arrangement and Signal name	Pin 41: R/W Pin 42: E	Pin 41: $\overline{RD}$ Pin 42: $\overline{WR}$	Pin 41: RD Pin 42: WR
Other	—	—	modified LCD driver interface timing

## Ordering Information

Type No.	CPU Interface	Package
HD63645F	68 family 2 MHz bus	80-pin plastic QFP (FP-80B)
HD64645F	Z80 family 4 MHz bus	80-pin plastic QFP (FP-80B)
HD64646FS	Z80 family 4 MHz bus	80-pin plastic QFP (FP-80B)

Pin Arrangement

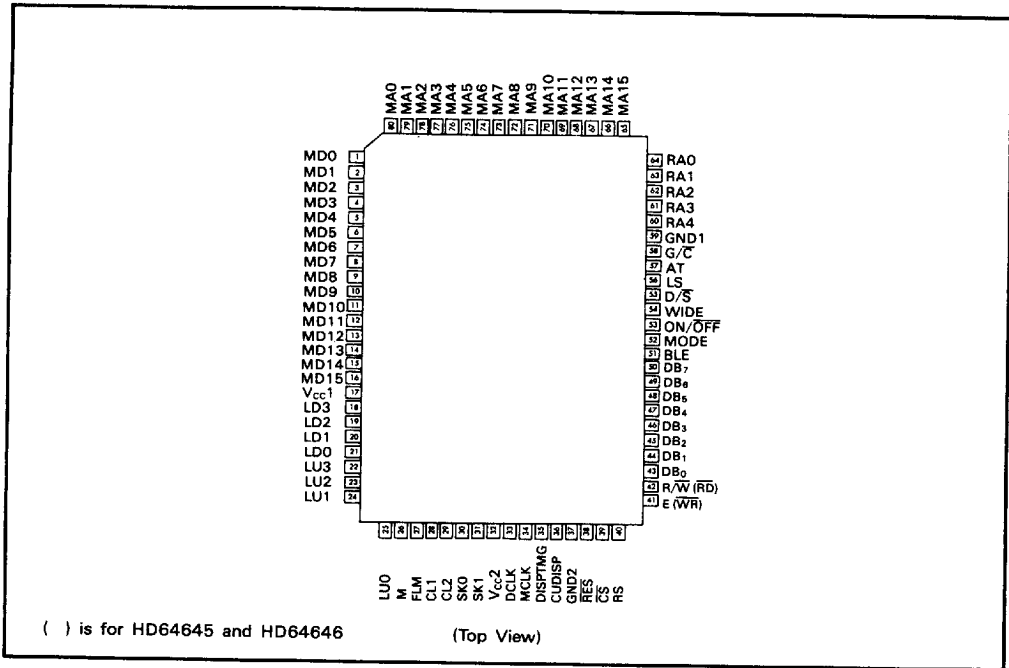

HITACHI

935

4496204 0046731 565

# HD63645/HD64645/HD64646

## Pin Description

Symbol	Pin Number	I/O	Name
Vcc1, Vcc2	17, 32	–	Vcc
GND1, GND2	37, 59	–	Ground
LU0-LU3	22-25	O	LCD Up Panel Data 0-3
LD0-LD3	18-21	O	LCD Down Panel Data 0-3
CL1	28	O	Clock One
CL2	29	O	Clock Two
FLM	27	O	First Line Marker
M	26	O	M
MA0-MA15	65-80	O	Memory Address 0-15
RA0-RA4	60-64	O	Raster Address 0-4
MD0-MD7	1-8	I	Memory Data 0-7
MD8-MD15	9-16	I	Memory Data 8-15
DB <sub>0</sub> -DB <sub>7</sub>	43-50	I/O	Data Bus 0-7
$\overline{CS}$	39	I	Chip Select
E	41	I	Enable (HD63645 Only)
R/ $\overline{W}$	42	I	Read/Write (HD63645 Only)
$\overline{WR}$	41	I	Write (HD64645 and HD64646)
$\overline{RD}$	42	I	Read (HD64645 and HD64646)
RS	40	I	Register Select
RES	38	I	Reset
DCLK	33	I	D Clock
MCLK	34	O	M Clock
DISPTMG	35	O	Display Timing
CUDISP	36	O	Cursor Display
SK0	30	I	Skew 0
SK1	31	I	Skew 1
ON/ $\overline{OFF}$	53	I	On/Off
BLE	51	I	Blink Enable
AT	57	I	Attribute
G/ $\overline{C}$	58	I	Graphic/Character
WIDE	54	I	Wide
LS	56	I	Large Screen
D/ $\overline{S}$	55	I	Dual/Single
MODE	52	I	Mode

**Pin Functions**

**Power Supply (V<sub>cc1</sub>, V<sub>cc2</sub>, GND)**

**Power Supply Pin (+5 V):** Connect V<sub>cc1</sub> and V<sub>cc2</sub> with +5 V power supply circuit.

**Ground Pin (0 V):** Connect GND1 and GND2 with 0 V.

**LCD Interface**

**LCD Up Panel Data (LU0-LU3), LCD Down Panel Data (LD0-LD3):** LU0-LU3 and LD0-LD3 output LCD data as shown in table 1.

**Clock One (CL1):** CL1 supplies timing clocks for display data latch.

**Clock Two (CL2):** CL2 supplies timing clock for display data shift.

**First Line Marker (FLM):** FLM supplies first line marker.

**M (M):** M converts liquid crystal drive output to AC.

**Memory Interface**

**Memory Address (MA0-MA15):** MA0-MA15 supply the display memory address.

**Raster Address (RA0-RA4):** RA0-RA4 supply the raster address.

**Memory Data (MD0-MD7):** MD0-MD7 receive the character dot data and bit-mapped data.

**Memory Data (MD8-MD15):** MD8-MD15 receive attribute code data and bit-mapped data.

**MPU Interface**

**Data Bus (DB0-DB7):** DB0-DB7 send/receive data as a three-state I/O common bus.

**Chip Select ( $\overline{CS}$ ):**  $\overline{CS}$  selects a chip. Low level enables MPU read/write of the LCTC internal registers.

**Enable (E):** E receives an enable clock. (HD63645 only).

**Read/Write (R/ $\overline{W}$ ):** R/ $\overline{W}$  enables MPU read of the LCTC internal registers when R/ $\overline{W}$  is high, and MPU write when low (HD63645 only).

**Write ( $\overline{WR}$ ):**  $\overline{WR}$  receives MPU write signal (HD64645 and HD64646).

**Read ( $\overline{RD}$ ):**  $\overline{RD}$  receives MPU read signal (HD64645 and HD64646).

**Register Select (RS):** RS selects registers. (Refer to table 5.)

**Reset ( $\overline{RES}$ ):**  $\overline{RES}$  performs external reset of the LCTC. Low level of  $\overline{RES}$  stops and zero-clears the LCTC internal counter. No register contents are affected.

**Timing Signal**

**D Clock (DCLK):** DCLK inputs the system clock.

**M Clock (MCLK):** MCLK indicates memory cycle; DCLK is divided by four.

**Display Timing (DISPTMG):** DISPTMG high indicates that the LCTC is reading display data.

**Cursor Display (CUDISP):** CUDISP supplies cursor display timing; connect with MD12 in character mode.

**Skew 0 (SK0)/Skew 1 (SK1):** SK0 and SK1 control skew timing. Refer to table 2.

**Mode Select**

The mode select pins ON/ $\overline{OFF}$ , BLE, AT, G/ $\overline{C}$ ,

**Table 1 LCD Up Panel Data and LCD Down Panel Data**

Pin name	Single Screen		Dual Screen
	4-Bit Data	8-Bit Data	
LU0-LU3	Data output	Data output	Data output for upper screen
LD0-LD3	Disconnected	Data output	Data output for lower screen

HITACHI

937

4496204 0046733 338

and **WIDE** are ORed with the mode register (**R22**) to determine the mode.

**On/Off (ON/OFF)**: **ON/OFF** switches display on and off (High = display on).

**Blink Enable (BLE)**: **BLE** high level enables attribute code "blinking" (**MD13**) and provides normal/blank blinking of specified characters for 32 frames each.

**Attribute (AT)**: **AT** controls character attribute functions.

**Graphic/Character (G/C)**: **G/C** switches between graphic and character display mode (graphic display when high).

**Wide (WIDE)**: **WIDE** switches between normal and wide display mode (high = wide display, low = normal display).

**Large Screen (LS)**: **LS** controls a large screen. **LS** high provides a data transfer rate of 40 Mbits/s for a graphic display. Also used to specify 8-bit LCD interface mode. For more details, refer to table 10.

**Dual/Single (D/S)**: **D/S** switches between single and dual screen display (dual screen display when high).

**Mode (MODE)**: **MODE** controls easy mode. **MODE** high sets duty ratio, maximum number of rasters, cursor start/end rasters, etc. (Refer to table 9.)

---

**Table 2 Skew Signals**

<b>SK0</b>	<b>SK1</b>	<b>Skew Function</b>
0	0	No skew
1	0	1-character time skew
0	1	2-character time skew
1	1	Prohibited combination

## Function Overview

### LCD and CRT Display Systems

Figure 1 shows a system using both LCD and CRT displays.

### Main Features of HD63645/HD64645/HD64646

Main features of the LCTC are:

- High-resolution liquid crystal display screen control (up to 720 × 512 dots)
- Software compatible with HD6845 (CRTC)
- Built-in character attribute control circuit

Table 3 shows how the LCTC can be used.

**Table 3 Functions, Application, and Configuration**

Classification	Item	Description
Functions	Screen Format	<ul style="list-style-type: none"> <li>• Programmable horizontal scanning cycle by the character clock period</li> <li>• Programmable multiplexing duty ratio from static up to 1/512</li> <li>• Programmable number of vertical displayed characters</li> <li>• Programmable number of rasters per character row (number of vertical dots within a character row + space between character rows)</li> </ul>
	Cursor Control	<ul style="list-style-type: none"> <li>• Programmable cursor display position, corresponding to RAM address</li> <li>• Programmable cursor height by setting display start/end rasters</li> <li>• Programmable blink rate, 1/32 or 1/64 frame rate</li> </ul>
	Memory Rewriting	<ul style="list-style-type: none"> <li>• Time for rewriting memory set either by specifying number of horizontal total characters or by cycle steal utilizing MCLK</li> </ul>
	Memory Addressing	<ul style="list-style-type: none"> <li>• 16-bit memory address output, up to 64 kbytes x 2 memory accessible</li> <li>• DRAM refresh address output</li> </ul>
	Paging and Scrolling	<ul style="list-style-type: none"> <li>• Paging by updating start address</li> <li>• Horizontal scrolling by the character, by setting horizontal virtual screen width</li> <li>• Vertical smooth scrolling by updating display start raster</li> </ul>
	Character Attributes	<ul style="list-style-type: none"> <li>• Reverse video, blinking, nondisplay (white or black), display ON/OFF</li> </ul>
	Application	CRTC Compatible
OR Function		<ul style="list-style-type: none"> <li>• Enables superimposing display of character screen and graphic screen</li> </ul>
Configuration	LCTC Configuration	<ul style="list-style-type: none"> <li>• Single 5 V power supply</li> <li>• I/O TTL compatible except <math>\overline{RES}</math>, MODE, SK0, SK1</li> <li>• Bus connectable with HMCS 6800 family (HD63645)</li> <li>• Bus connectable with 80 family (HD64645 and HD64646)</li> <li>• CMOS process</li> <li>• Internal logic fully static</li> <li>• 80-pin flat plastic package</li> </ul>

HITACHI

4496204 0046735 100

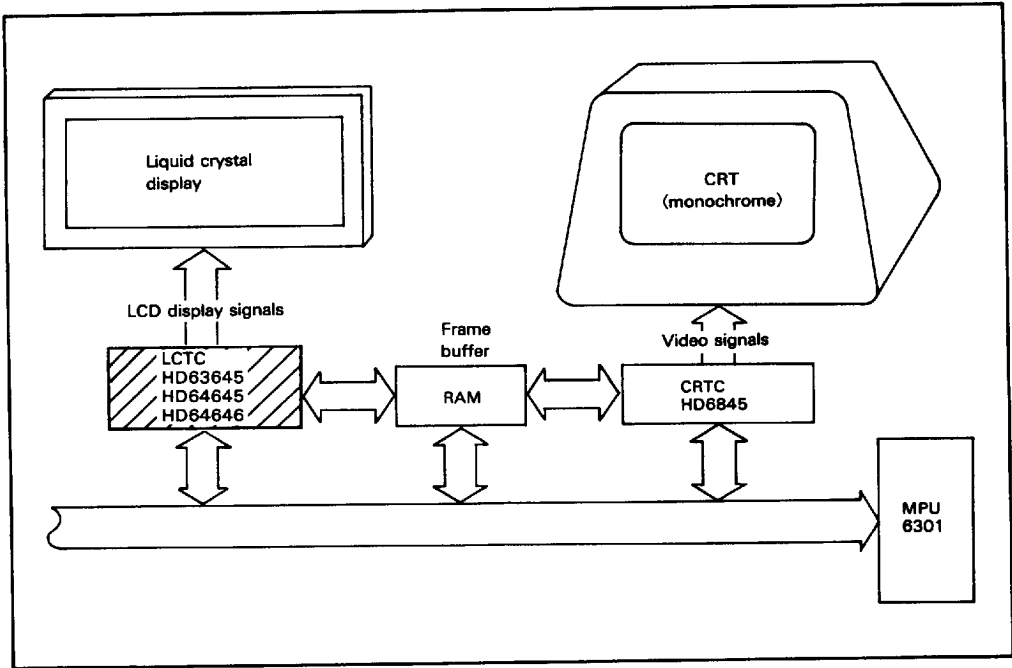

Figure 1 LCD and CRT Displays

**Differences Between HD64645 and HD64646**

Figure 2 and figure 3 show the relation between display data transfer period, when display data shift clock CL2 changes, and display data latch clock CL1. Figure 2 shows the case without skew function and figure 3 shows the case with skew function.

In figure 2, high period between CL2 and CL1 of HD64645 overlap. HD64646 has no overlap

like HD64645, and except for this overlap. HD64646 is the same as HD64645 functionally.

Also for the skew function, phase relation between CL1 and CL2 changes. As figure 3 shows, data transfer period and CL1 high period of HD64646 never overlap with the skew function.

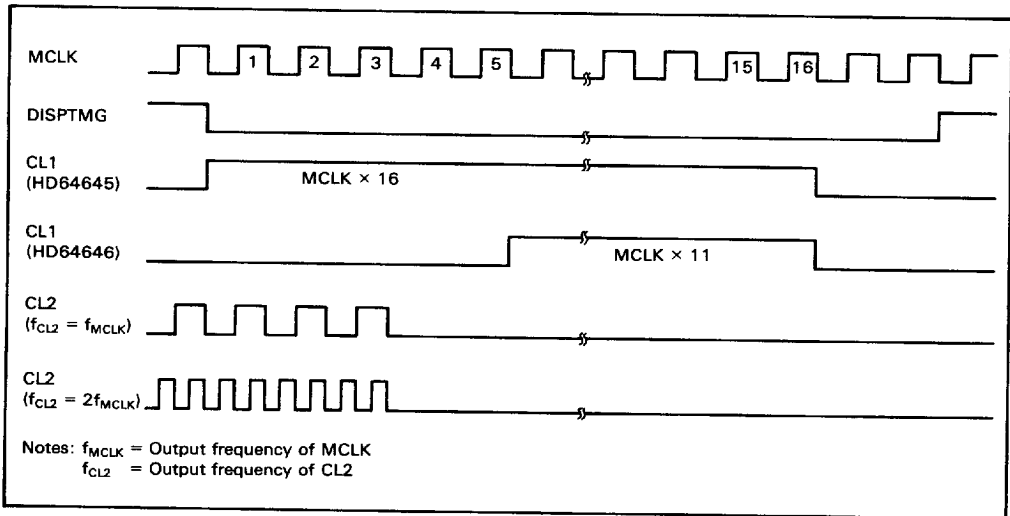

**Figure 2 Differences between HD64645 and HD64646 (no skew)**

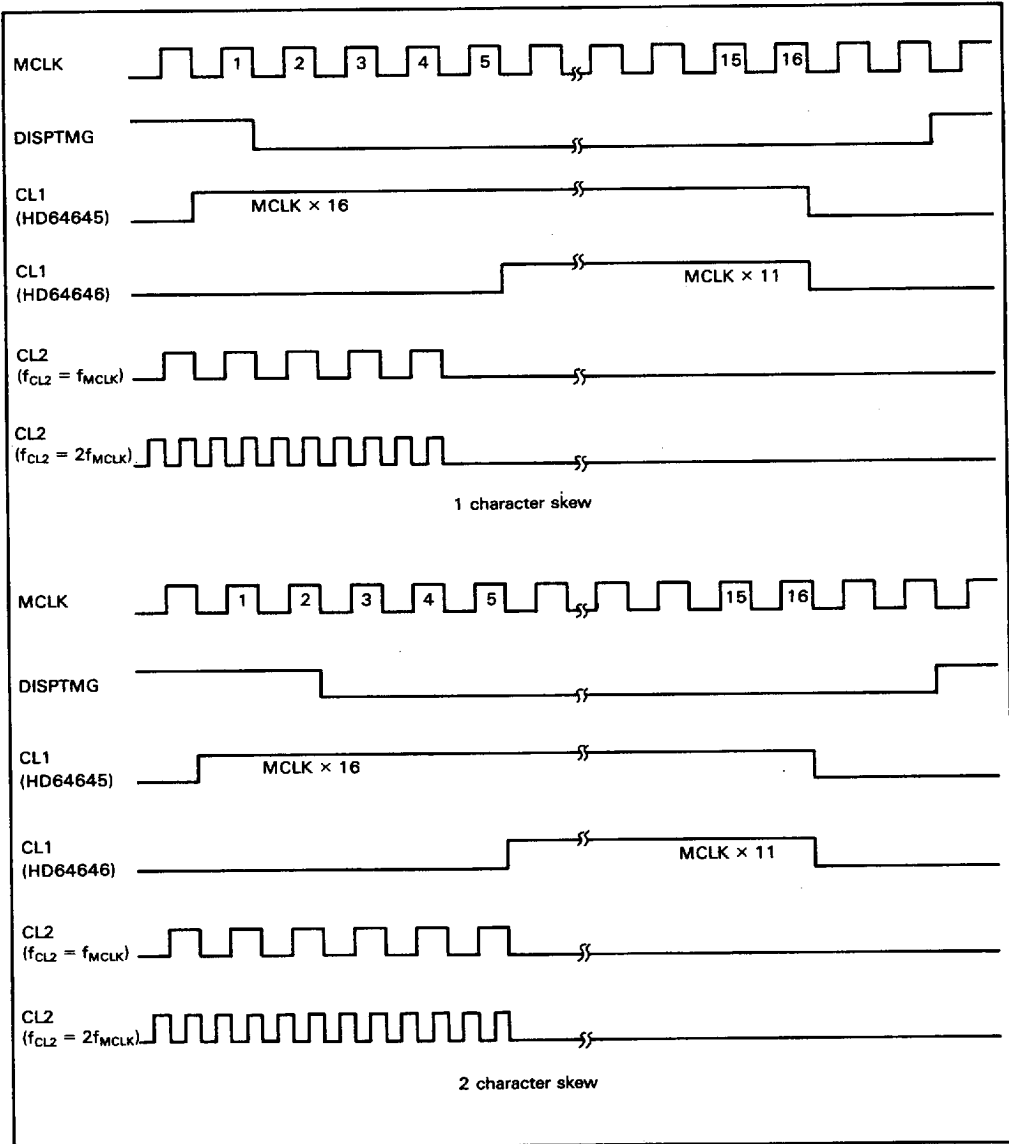
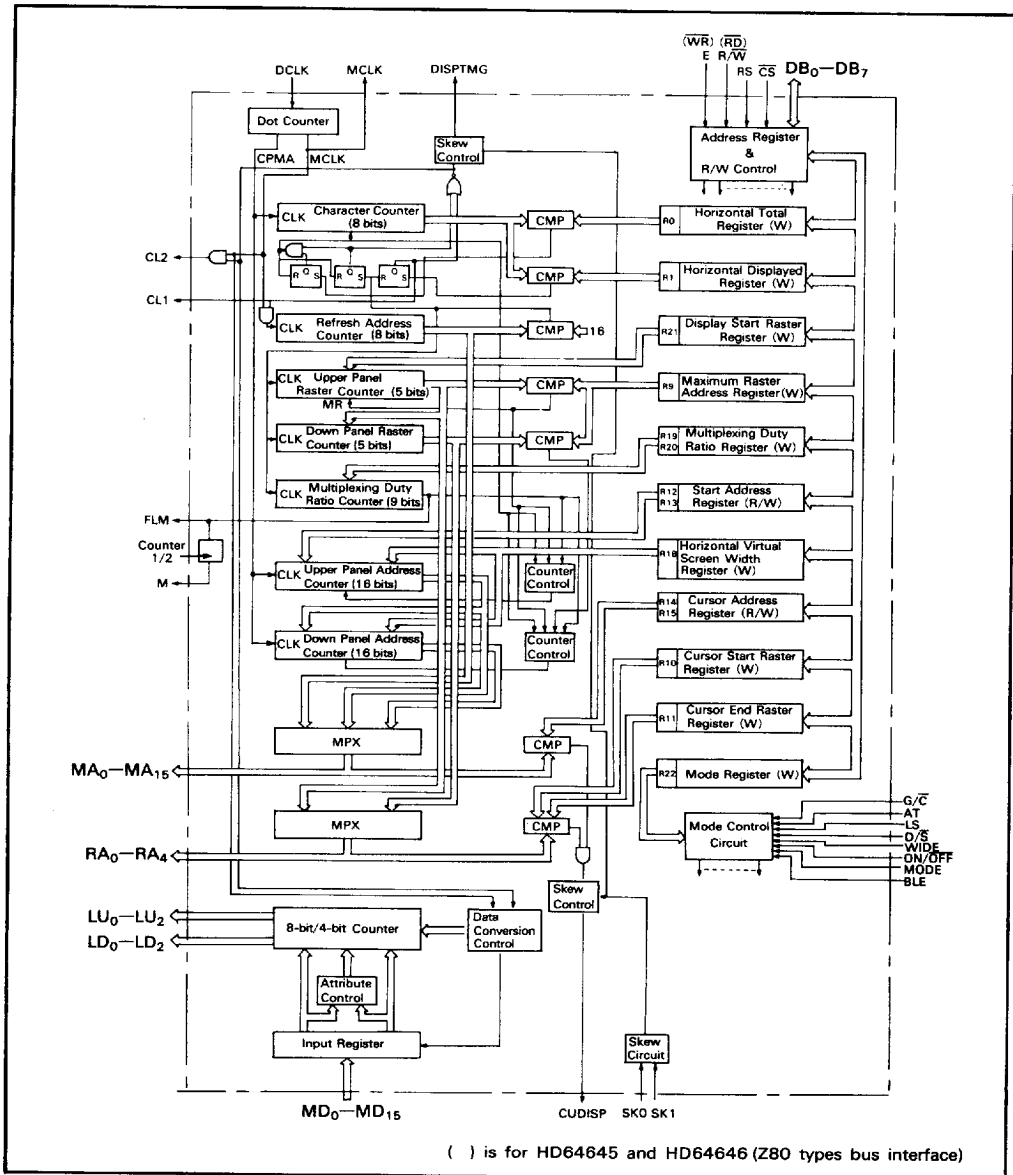

Figure 3 Differences between HD64645 and HD64646 (skew)

**Internal Block Diagram**

Figure 4 is a block diagram of the LCTC.



**Figure 4 LCTC Block Diagram**

**HITACHI**

4496204 0046739 856



**Interface to MPU**

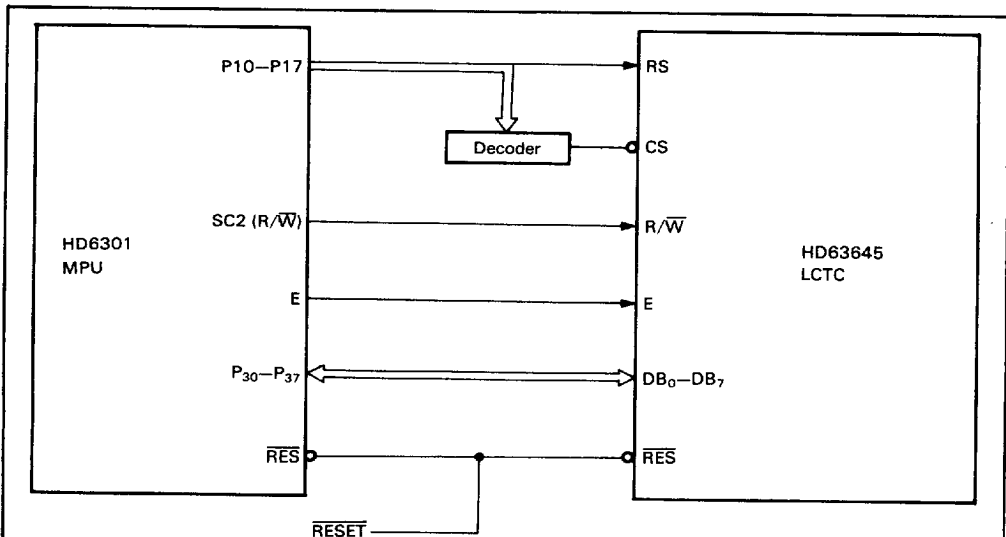

Note: HD6301 is set in mode 5. P10-P17 are used as output ports, and P30-P37 as data buses. SC2 outputs R/W here.

Interface between HD6301 and HD63645

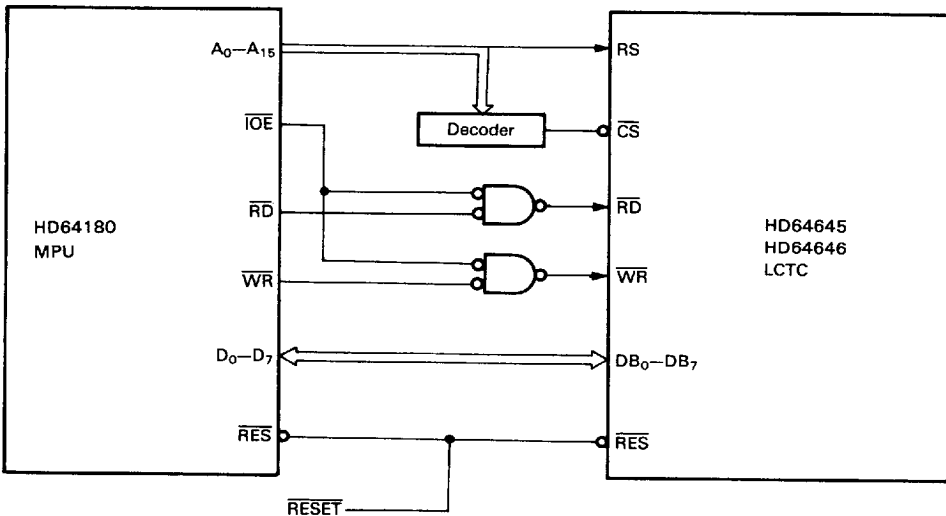

Note: In 80 family MPUs, I/O space is separate from memory space in software. Thus the LCTC, a part of I/O, needs the ORed signals of the interface signals and IOE. So IOE and RD, and IOE and WR should be ORed to satisfy  $t_{AS}$ , the timing of CS, RD, and WR.

Interface between HD64180, HD64645 and HD64646

**Figure 6 Interface to MPU**

**HITACHI**

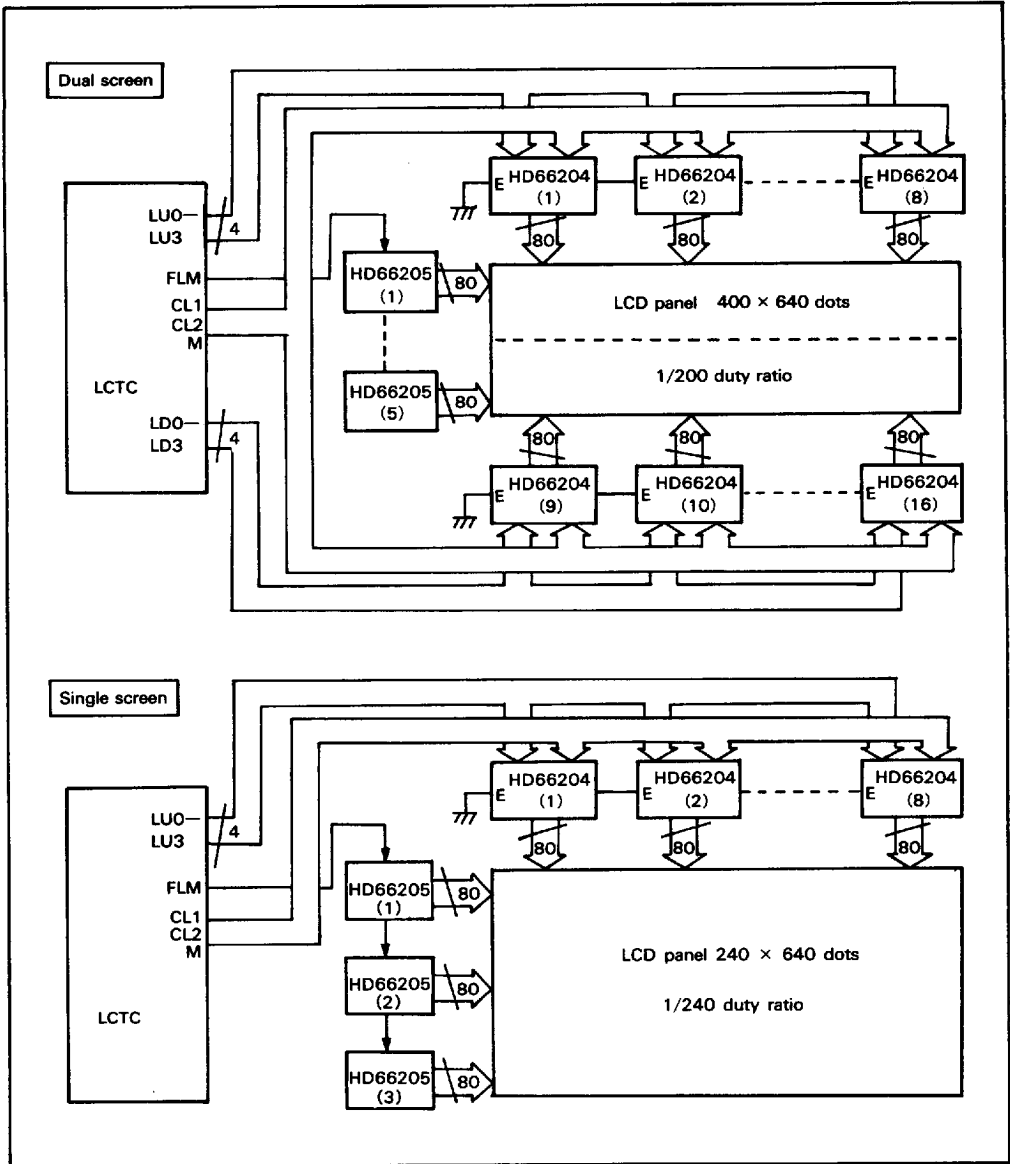

Figure 7 LCD Driver Examples

**Registers**

Table 4 shows the register mapping. Table 5 describes their function. Table 6 shows the differences between CRTC and LCTC registers.

**Table 4 Registers Mapping**

Address		Reg.	Register Name	Program Unit	Symbol	R/W	Data Bit								
CS	RS						4	3	2	1	0	7	6	5	4
1	—	—	Invalid	—	—	—									
0	0	—	AR Address Register	—	—	W									
0	1	00000	R0 Horizontal Total Characters	Character <sup>3</sup>	Nht	W									
0	1	00001	R1 Horizontal Displayed Char.s	Character	Nhd	W									
0	1	01001	R9 Maximum Raster Address	Raster	Nr	W									
0	1	01010	R10 Cursor Start Raster	Raster <sup>4</sup>	Ncs	W	B P								
0	1	01011	R11 Cursor End Raster	Raster	Nce	W									
0	1	01100	R12 Start Address (H)	Memory Address	—	R/W									
0	1	01101	R13 Start Address (L)	Memory Address	—	R/W									
0	1	01110	R14 Cursor Address (H)	Memory Address	—	R/W									
0	1	01111	R15 Cursor Address (L)	Memory Address	—	R/W									
0	1	10010	R18 Horizontal Virtual Screen WidthCharacter	Nir	Nir	W									
0	1	10011	R19 Multiplexing Duty Ratio (H)	Raster <sup>3</sup>	Ndh	W									
0	1	10100	R20 Multiplexing Duty Ratio (L)	Raster <sup>3</sup>	Ndl	W									
0	1	10101	R21 Display Start Raster	Raster	Nsr	W									
0	1	10110	R22 Mode Register	—Note <sup>5</sup>	—	W			ON/ OFF	G/C	WIDE	BLE	AT		

- Notes:
1. : Invalid data bits
  2. R/W indicates whether write access or read access is enabled to/from each register.  
W: Only write accessible  
R/W: Both read and write accessible
  3. The "value to be specified minus 1" should be programmed in these registers: R0, R1 and R20.
  4. Data bits 5 and 6 of cursor start register control the cursor status as shown below.  
(For more details, refer to page 27).
- | B | P | Cursor Blink Mode             |
|---|---|-------------------------------|
| 0 | 0 | Cursor on; without blinking   |
| 0 | 1 | Cursor off                    |
| 1 | 0 | Blinking once every 32 frames |
| 1 | 1 | Blinking once every 64 frames |
5. The OR of mode pin status and mode register data determines the mode.
  6. Registers R2-R8, R16, and R17 are not assigned for the LCTC. Programming to these registers will be ignored.

**Table 5 Internal Register Description**

<b>Reg. No.</b>	<b>Register Name</b>	<b>Size(Bits)</b>	<b>Description</b>
AR	Address Register	5	Specifies the internal control registers (R0, R1, R9-R15, R18-R22) address to be accessed
R0	Horizontal Total Characters	8	Specifies the horizontal scanning period
R1	Horizontal Displayed Characters	8	Specifies the number of displayed characters per character row
R9	Maximum Raster Address	5	Specifies the number of rasters per character row, including the space between character rows
R10	Cursor Start Raster	5 + 2	Specifies the cursor start raster address and its blink mode
R11	Cursor End Raster	5	Specifies the cursor end raster address
R12	Start Address (H)	16	Specify the display start address
R13	Start Address (L)		
R14	Cursor Address (H)	16	Specify the cursor display address
R15	Cursor Address (L)		
R18	Horizontal Virtual Screen Width	8	Specifies the length of one row in memory space for horizontal scrolling
R19	Multiplexing Duty Ratio (H)	9	Specify the number of rasters for one screen
R20	Multiplexing Duty Ratio (L)		
R21	Display Start Raster	5	Specifies the display start raster within a character row for smooth scrolling
R22	Mode Register	5	Controls the display mode

Note: For more details of registers, refer to "Internal Registers".

**Table 6 Internal Register Comparison between LCTC and CRTC**

<b>Reg. No.</b>	<b>LCTC HD63645/HD64645/HD64646</b>	<b>Comparison</b>	<b>CRTC HD6845</b>
AR	Address Register	Equivalent to CRTC	Address Register
R0	Horizontal Total Characters		Horizontal Total Characters
R1	Horizontal Displayed Characters		Horizontal Displayed Characters
R2	—	Particular to CRTC ; unnecessary for LCTC	Horizontal Sync Position
R3			Sync Width
R4			Vertical Total Characters
R5			Vertical Total Adjust
R6			Vertical Displayed Characters
R7			Vertical Sync Position
R8			Interlace and Skew
R9	Maximum Raster Address	Equivalent to CRTC	Maximum Raster Address
R10	Cursor Start Raster		Cursor Start Raster
R11	Cursor End Raster		Cursor End Raster
R12	Start Address (H)		Start Address (H)
R13	Start Address (L)		Start Address (L)
R14	Cursor Address (H)		Cursor (H)
R15	Cursor Address (L)		Cursor (L)
R16		Particular to CRTC ; unnecessary for LCTC	Light Pen (H)
R17			Light Pen (L)
R18	Horizontal Virtual Screen Width	Additional registers for LCTC	
R19	Multiplexing Duty Ratio (H)		
R20	Multiplexing Duty Ratio (L)		
R21	Display Start Raster		
R22	Mode Register		

**Functional Description**

**Programmable Screen Format**

Figure 8 illustrates the relation between LCD

display screen and registers. Figure 9 shows a timing chart of signals output from the LCTC in mode 5 as an example.

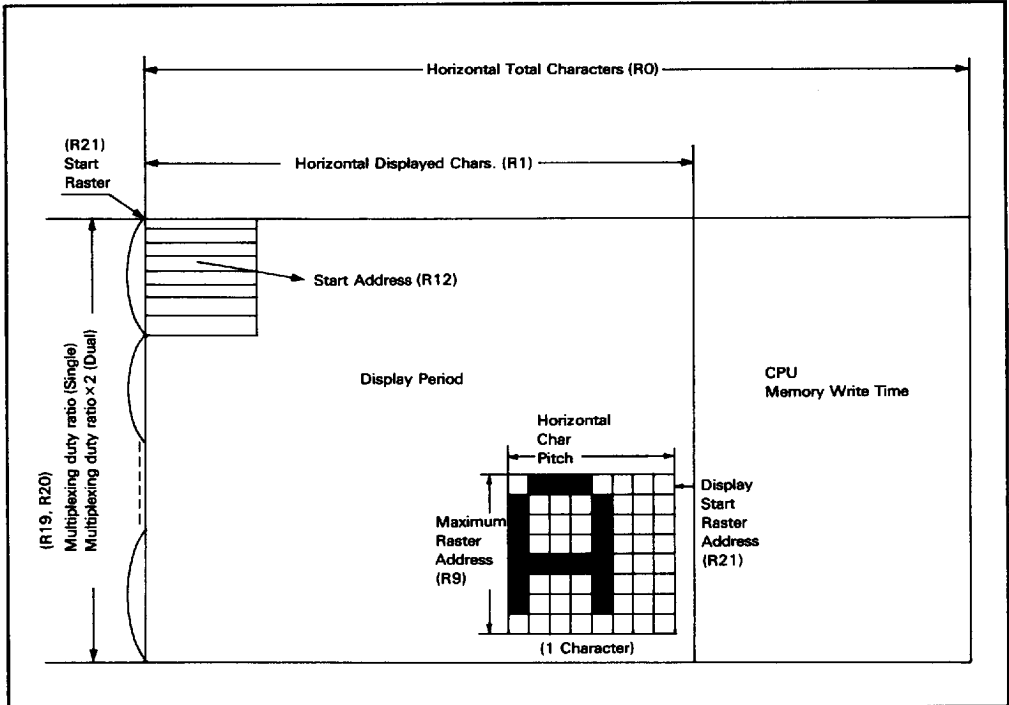

**Figure 8 Relation between Display Screen and Registers**

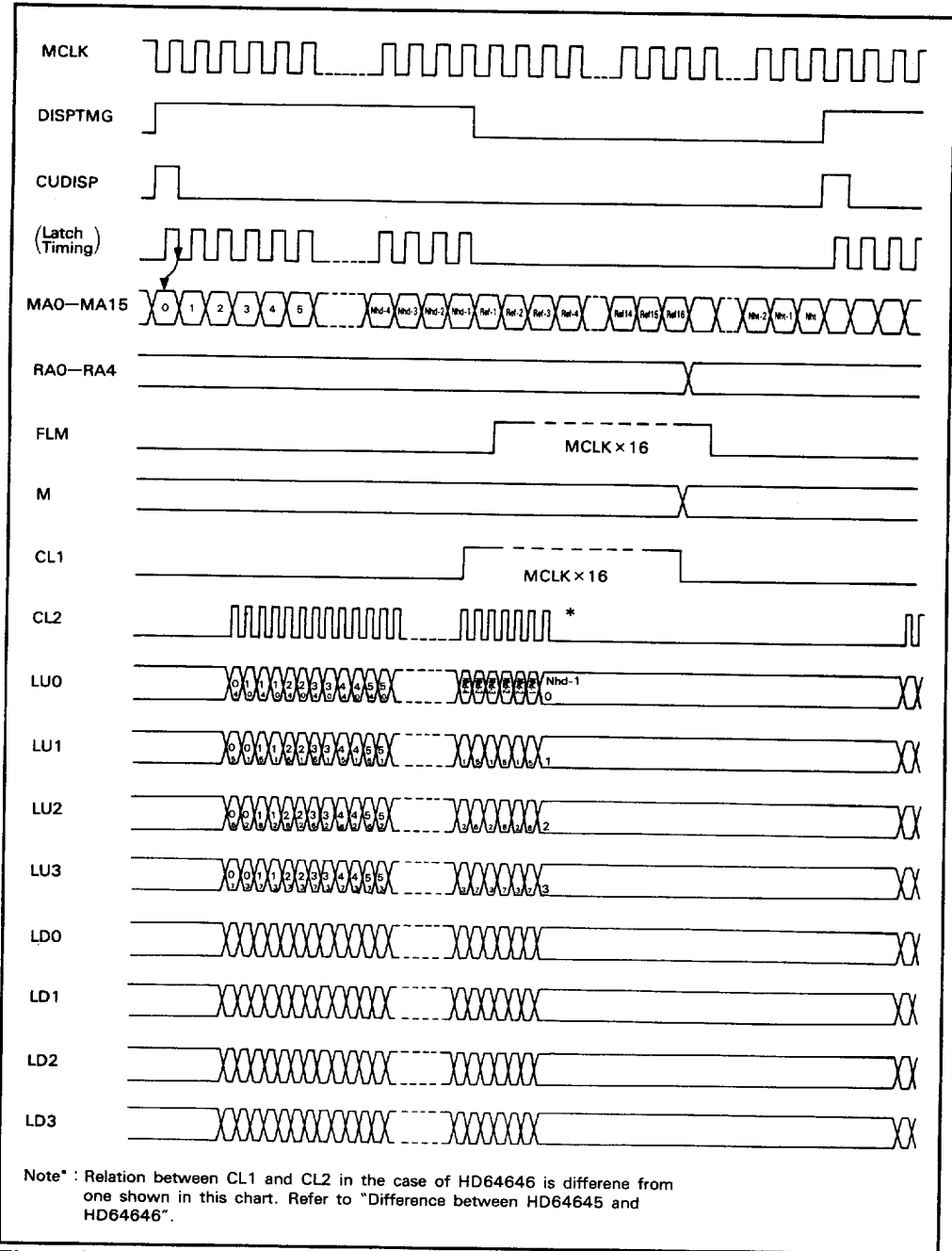

Figure 9 LCTC Timing Chart (In Mode 5: Single Screen, 4-Bit Transfer, Normal Character Display)

HITACHI

4496204 0046747 922

**Cursor Control**

The following cursor functions (figure 10) can be controlled by programming specific registers.

- Cursor display position

- Cursor height
- Cursor blink mode

A cursor can be displayed only in character mode. Also, CUDISP pin must be connected to MD12 pin to display a cursor.

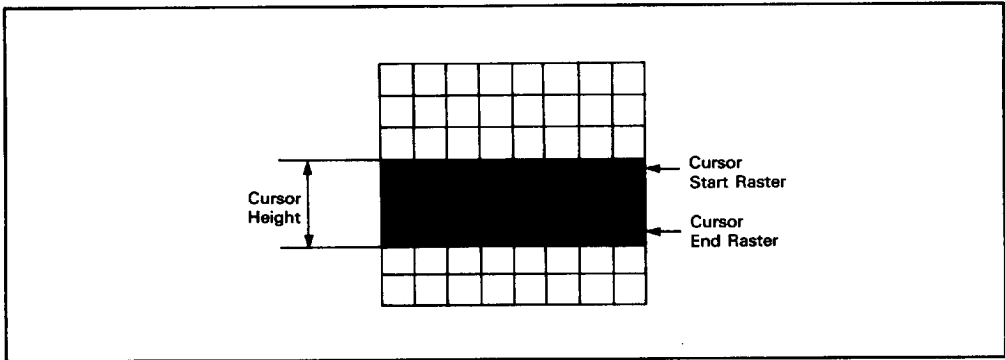

**Figure 10 Cursor Display**

**Character Mode and Graphic Mode**

The LCTC supports two types of display modes; character mode and graphic mode. Graphic mode 2 is provided to utilize software for a system using the CRTIC (HD6845).

The display mode is controlled by an OR between the mode select pins (D/S, G/C, LS, WIDE, AT) and mode register (R22).

**Character Mode:** Character mode displays characters by using CG-ROM. The display data supplied from memory is accessed in 8-bit units. A variety of character attribute functions are provided, such as reverse video, blinking, nondisplay (white or black), by storing the attribute data in attribute RAM (A-RAM).

Figure 11 illustrates the relation between character display screen and memory contents.

**Graphic Mode 1:** Graphic mode 1 directly displays data stored in a graphic memory buffer. The display data supplied from memory is accessed in 16-bit units. Character attribute functions or wide mode are not provided. Figure 12 illustrates the relation between graphic display screen and memory contents.

**Graphic Mode 2:** Graphic mode 2 utilizes software for a system using the CRTIC (HD6845). The display data supplied from memory is accessed in 16-bit units. Character attribute functions or wide mode are not provided. The same memory addresses are output repeatedly the number of times specified by maximum raster register (R9). The raster address is output in the same way as in character mode.

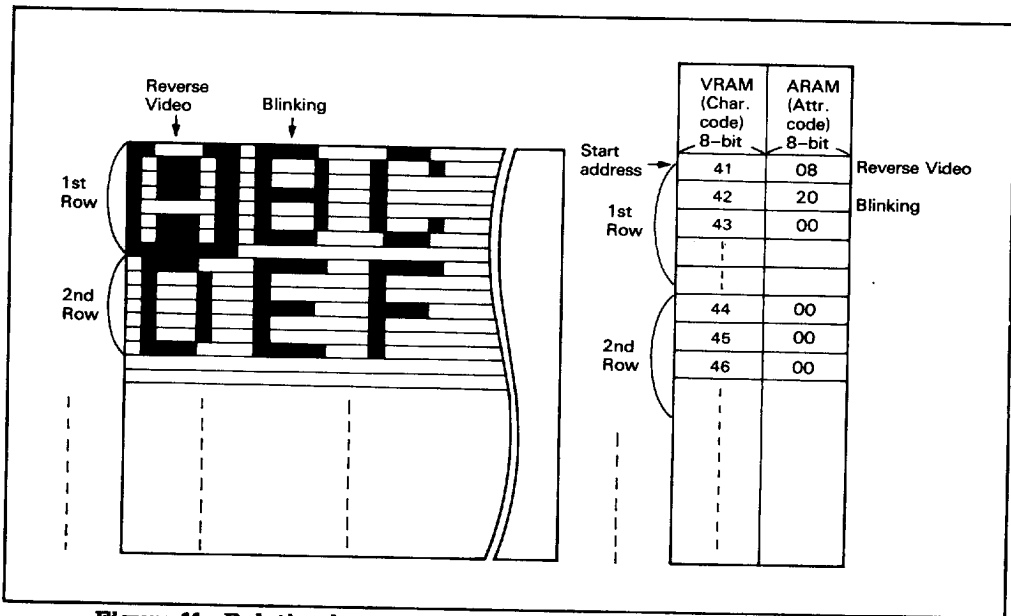

**Figure 11 Relation between Character Screen and Memory Contents**

HITACHI

4496204 0046749 7T5

## Horizontal Virtual Screen Width

Horizontal virtual screen width can be specified by the character in addition to the number of horizontal displayed characters (figure 13).

The display screen can be scrolled in any

direction by the character, by setting the horizontal virtual screen width and updating the start address. This function is enabled by programming the horizontal virtual screen width register (R18).

Figure 14 shows an example.

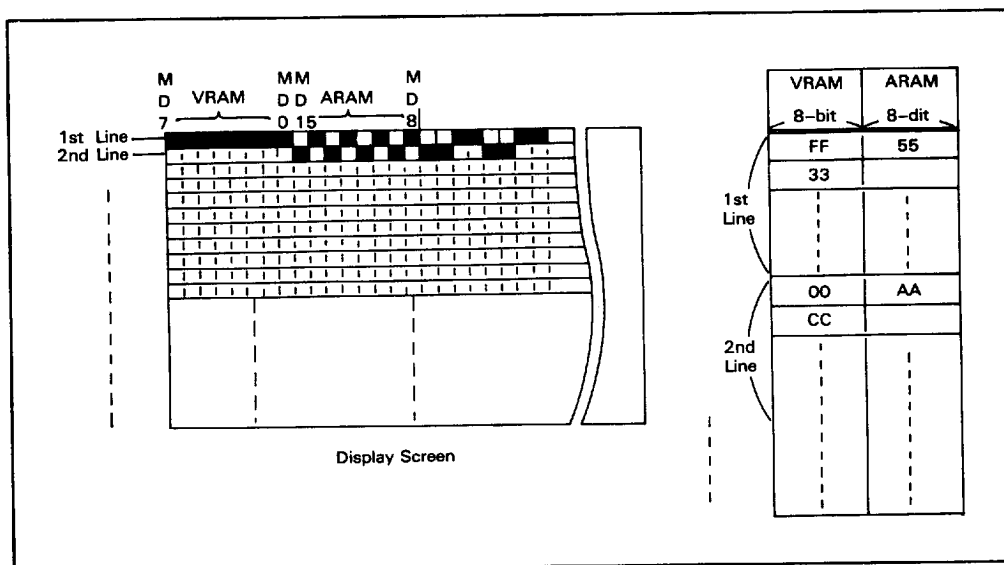

**Figure 12 Relation between Graphic Screen and Memory Contents**

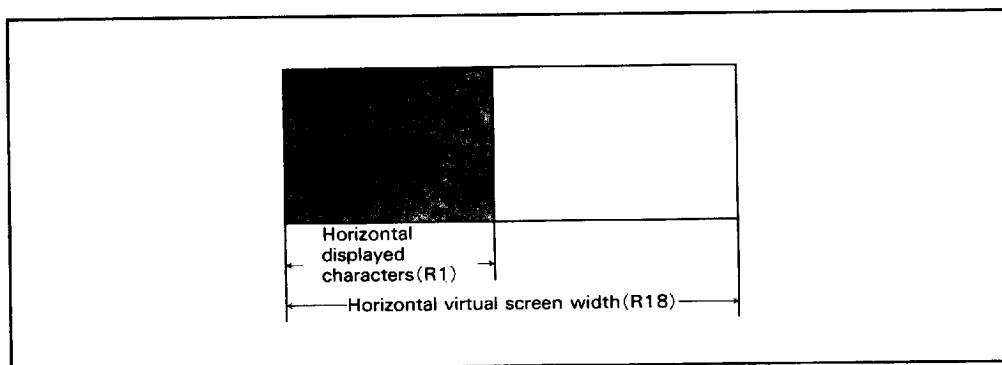

**Figure 13 Horizontal Virtual Screen Width**

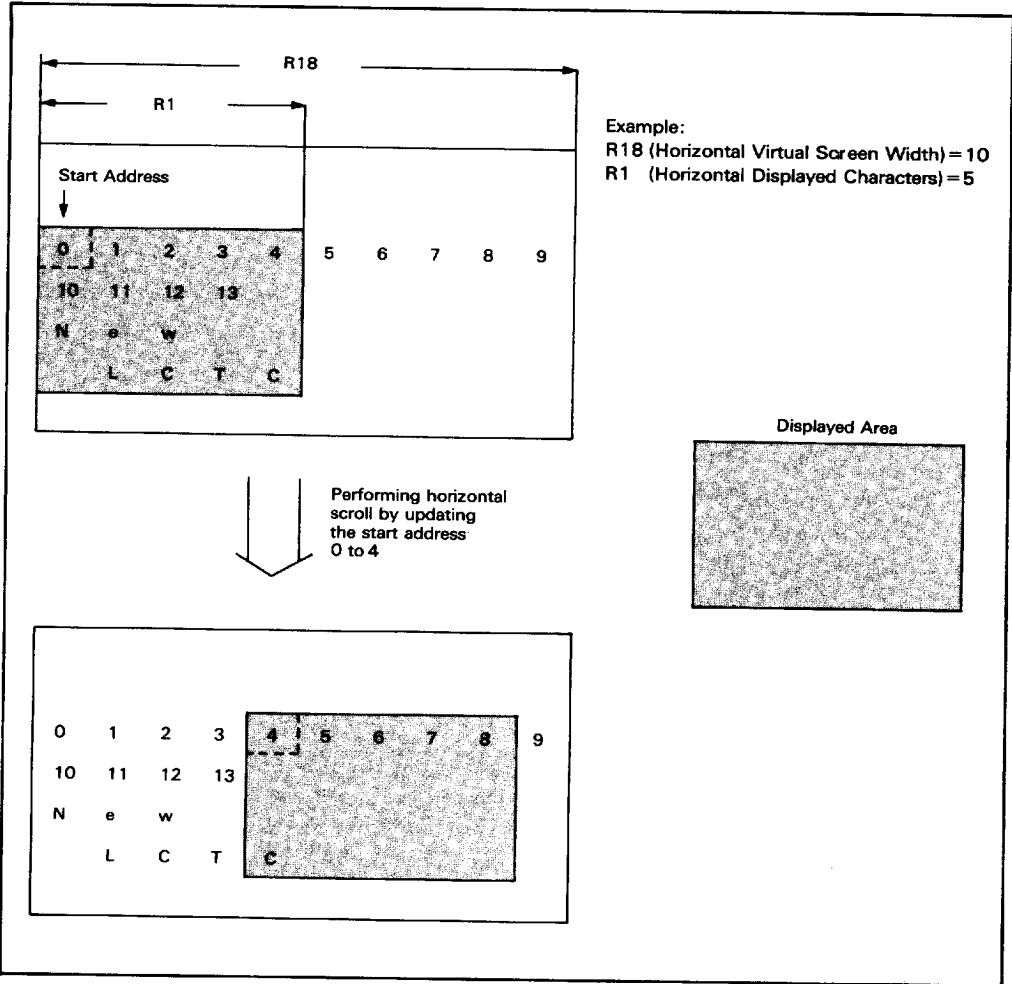

Figure 14 Example of Horizontal Scroll by Setting Horizontal Virtual Screen Width

**Smooth Scroll**

Vertical smooth scrolling (figure 15) is performed by updating the display start raster, as specified by the start raster register (R21). This function is offered only in character mode.

**Wide Display**

The character to be displayed can be doubled in width, by supplying the same data twice in width (figure 16). This function is offered only in character mode, and controlled either by bit 2 of the mode register (R22) or by the WIDE pin.

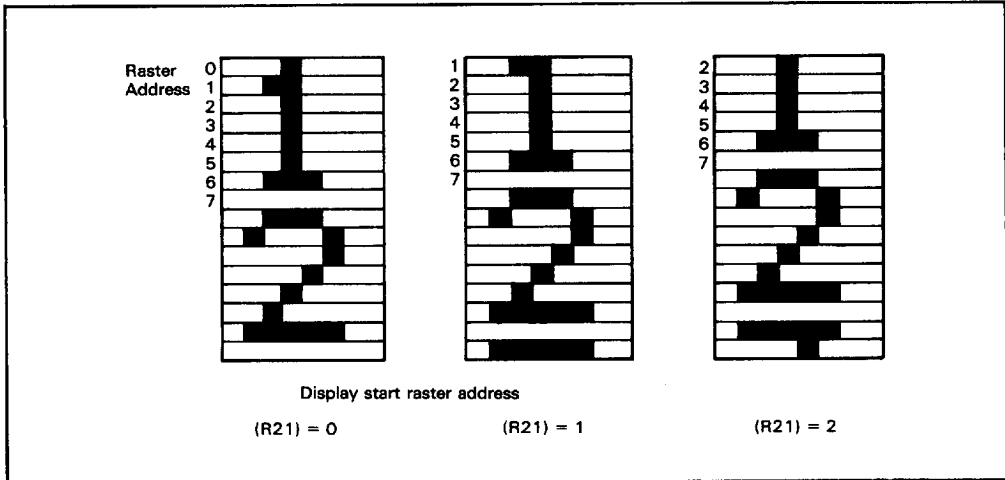

**Figure 15 Example of Smooth Scroll by Setting Display Start Raster Address**

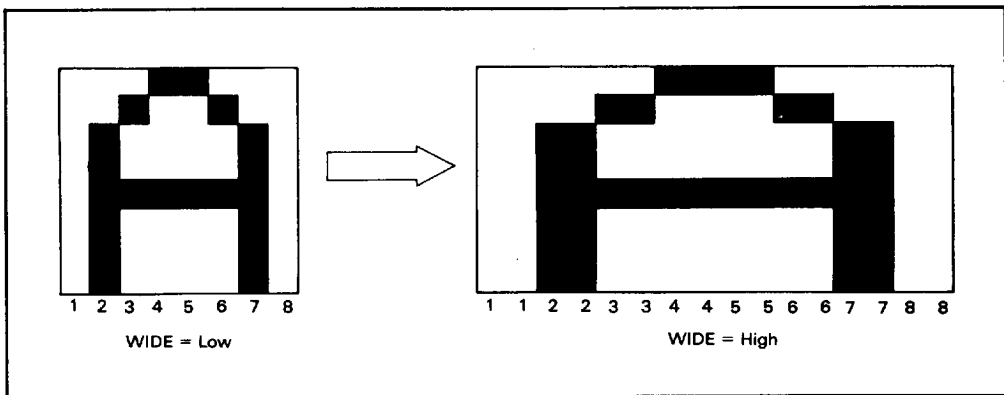
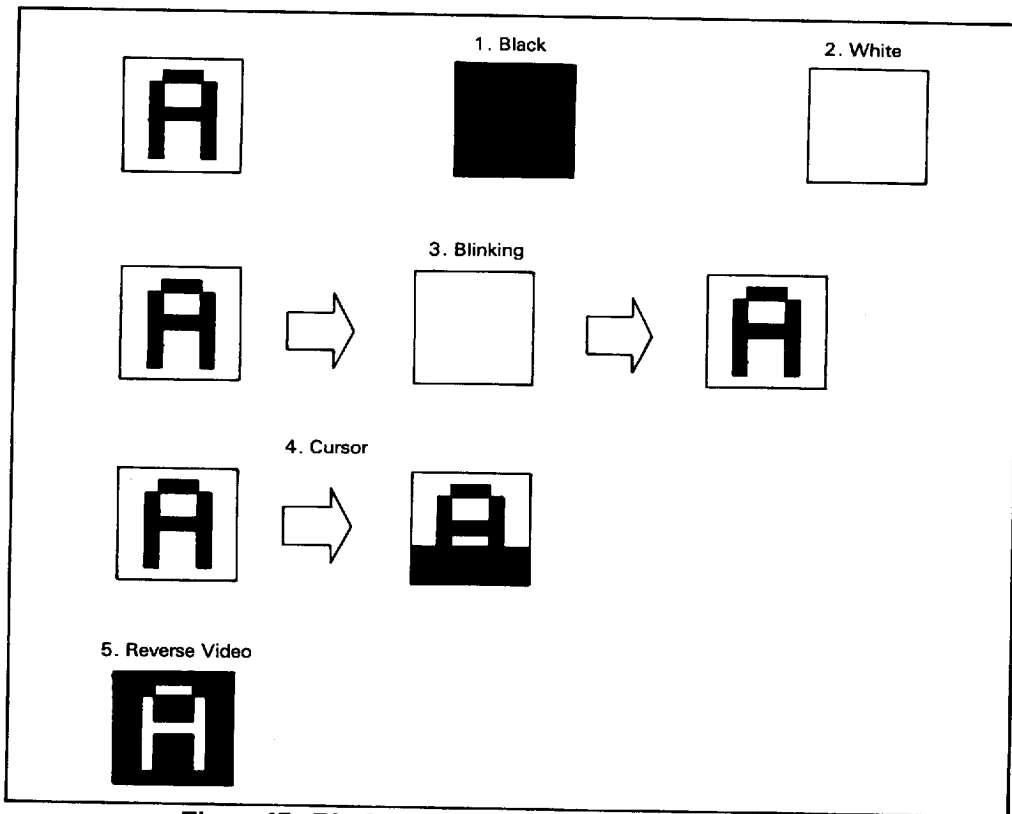

**Figure 16 Example of Wide Display**

**Attribute Functions**

A variety of character attribute functions such as reverse video, blinking, nondisplay (white) or nondisplay (black) can be implemented by storing the attribute data in A-RAM (attribute RAM). Figure 17 shows a display example using each attribute function.

The attribute functions are offered only in character mode, and controlled either by bit 0 of the mode register (R22) or the AT pin. As shown in figure 18, a character attribute can be specified by placing the character code on MD0-MD7, and the attribute code on MD11-MD15. MD8-MD10 are invalid.



**Figure 17 Display Example Using Attribute Functions**

MD Input	15	14	13	12	11	10-8	7-0
Function	Non-display (black)	Non-display (white)	Blinking	Cursor	Reverse video	***	Character Code

\*: Invalid

**Figure 18 Attribute Code**

**HITACHI**

4496204 0046753 126

**OR Function—Superimposing Characters and Graphics**

The OR function (figure 19) generates the OR of the data entered into MD0-MD7 (e.g. character data) and the data into MD8-MD15 (e.g. graphic data) in the LCTC and transfers

this data as 1 byte.

This function is offered only in character mode, and controlled by bit 0 of the mode register (R22) or by the AT pin. Any attribute functions are disabled when using the OR function.

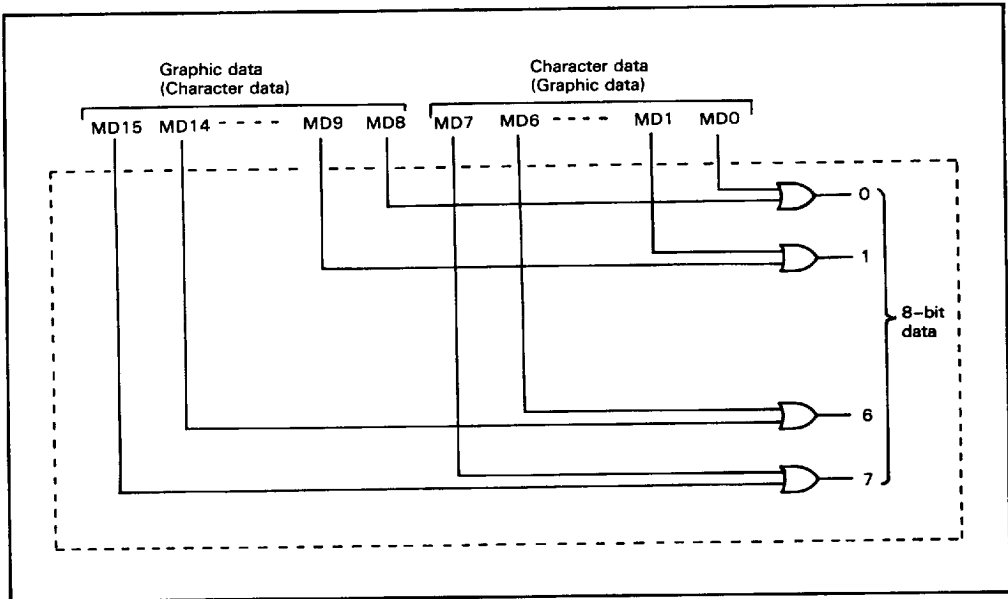

**Figure 19 OR Function**

**DRAM Refresh Address Output Function**

The LCTC outputs the address for DRAM refresh while CL1 is high, as shown in figure 20. The 16 refresh addresses per scanned line are output 16 times, from \$00-\$FF.

**Skew Function**

The LCTC can specify the skew (delay) for CUDISP, DISPTMG, CL2 outputs and MD inputs.

If buffer memory and character generator ROM cannot be accessed within one hori-

zontal character display period, the access is retarded to the next cycle by inserting a latch to memory address output and buffer memory output. The skew function retards the CUDISP, DISPTMG, CL2 outputs, and MD inputs in the LCTC to match phase with the display data signal.

By utilizing this function, a low-speed memory can be used as a buffer RAM or a character generator ROM.

This function is controlled by pins SK0 and SK1 as shown in table 7.

**Table 7 Skew Function**

SK0	SK1	Skew Function
0	0	No skew
1	0	1 character time skew
0	1	2 character time skew
1	1	Inhibited combination

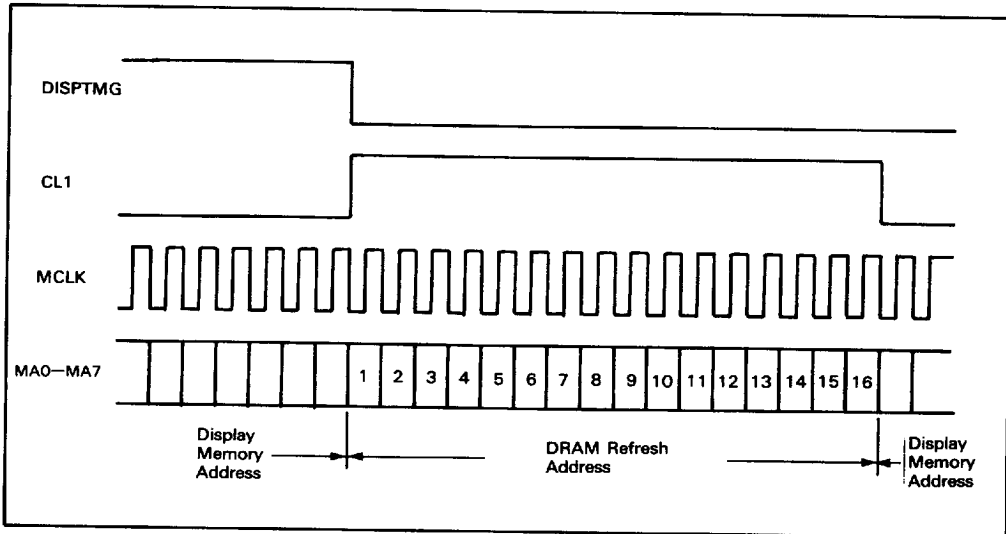

**Figure 20 DRAM Refresh Address Output**

HITACHI

4496204 0046755 TT9

**Easy Mode**

This mode utilizes software for systems using the CRTC (HD6845). By setting MODE pin to high, the display mode and screen format are fixed as shown in table 8. With this mode, software for a CRT screen can be utilized in a system using the LCTC, without changing the BIOS.

**Automatic Correction of Down Panel Raster Address**

When the LCTC mode is set for character display and dual screen, memory addresses (MA) and raster addresses (RA) are output in such a way as to keep continuity of a display spread over the two panels. Therefore users can use the LCTC without considering the multiplexing duty ratio (the number of vertical dots of a screen) or the character font. (See figure 21.)

**Table 8 Fixed Values in Easy Mode**

Reg. No.	Register Name	Fixed Value (decimal)
R9	Maximum raster address	7
R10	Cursor start raster	6
R11	Cursor end raster	7
R18	Horizontal virtual screen width	Same value as (R1)
R19	Multiplexing duty ratio (H)	99 (in dual screen mode)
R20	Multiplexing duty ratio (L)	199 (in single screen mode)
R21	Display start raster	0
R22	Mode register	0

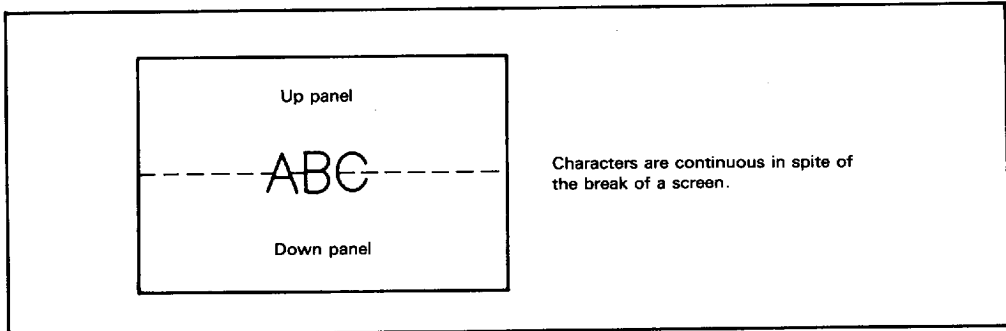

**Figure 21 Example of the Display in the Character Mode**

## System Configuration and Mode Setting

### LCD System Configuration

The screen configuration, single or dual, must be specified when using the LCTC system (figure 22).

Using the single screen configuration, you can construct an LCD system with lower cost than a dual screen system, since the required number of column drivers is smaller and the manufacturing process for mounting them is simpler. However, there are some limitations, such as duty ratio, breakdown voltage of a driver, and display quality of the liquid crystal, in single screen configuration. Thus, a dual screen configuration may be more suitable to an application.

The LCTC also offers an 8-bit LCD data transfer function to support an LCD screen with a smaller interval of signal input terminals. For a general size LCD screen, such as 640 × 200 single, or 640 × 400 dual, the usual 4-bit LCD data transfer is satisfactory.

### Hardware Configuration and Mode Setting

The LCTC supports the following hardware configurations:

- Single or dual screen configuration
- 4-or 8-bit LCD data transfer

and the following screen format:

- Character, graphic 1, or graphic 2 display
- Normal or wide display (only in character mode)
- OR or attribute display (only in character mode)

Also, the LCTC supports up to 40 Mbits/s of large screen mode (mode 13) for large screen display. This mode is provided only in graphic 1 mode.

Table 9 shows the mode selection method according to hardware configuration and screen format. Table 10 shows how they are specified.

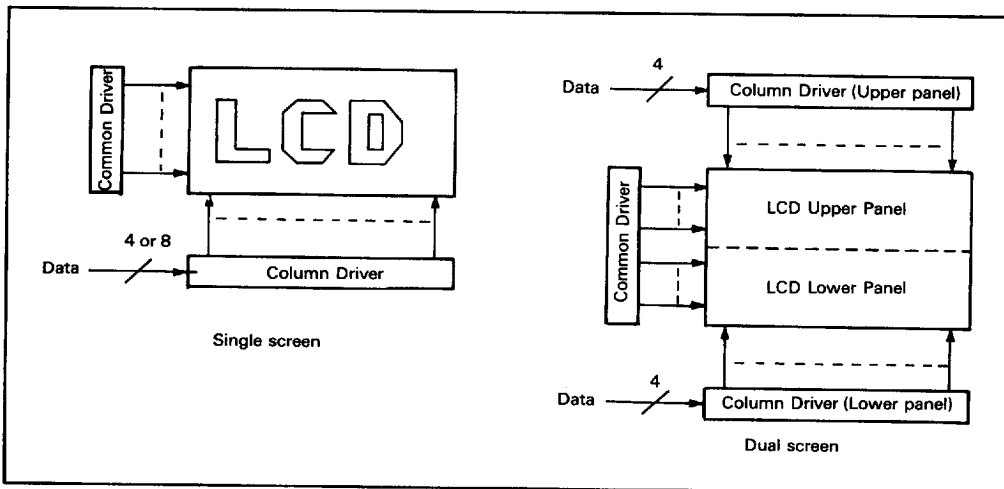

Figure 22 Hardware Configuration According to Screen Format

HITACHI

961

■ 4496204 0046757 871 ■

# HD63645/HD64645/HD64646

**Table 9 Mode Selection**

Hardware Configuration			Screen Format						
LCD Data Transfer	Screen Configuration	Screen Size	Character/Graphic	Normal/Wide	Attributes/OR	Maximum data transfer speed (Mbps)	Mode No.		
4-bit	Single	Normal	Character	Normal	AT OR	20	5		
				Wide	AT OR	10	6		
			Graphic 1				20	7	
			Graphic 2				20	8	
			Dual	Normal	Character	Normal	AT OR	20	1
						Wide	AT OR	10	2
	Graphic 1						20	3	
	Graphic 2						20	4	
	Large				Graphic 1			40	13
	8-bit	Single	Normal	Character	Normal	AT OR	20	9	
					Wide	AT OR	10	10	
Graphic 1						20	11		
Graphic 2						20	12		

**Note:** Maximum data transfer speed indicates amount of the data read out of a memory. Thus, the data transfer speed sent to the LCD driver in wide function is 20 Mbps.

Mode List

Table 10 Mode List

No.	Mode Name	Pin Name					Screen Config.	Graphic/Character	Data Transfer	Wide Display	Attribute
		D/ $\bar{S}$	G/ $\bar{C}$	LS	WIDE	AT					
1	Dual-screen character	1	0	0	0	0	Dual screen	Character	4-bit × 2	Normal	OR
2	Dual-screen wide character	1	0	0	1	0				Wide	OR
		1	0	0	1	1				AT	
3	Dual-screen graphic 1	1	1	0	0	1	Graphic	—	—	—	
4	Dual-screen graphic 2	1	1	0	0	0					
5	Single-screen character	0	0	0	0	0	Single screen	Character	4-bit	Normal	OR
		0	0	0	0	1				AT	
6	Single-screen wide character	0	0	0	1	0				Wide	OR
		0	0	0	1	1	AT				
7	Single-screen graphic 1	0	1	0	0	1	Graphic	—	—	—	
8	Single-screen graphic 2	0	1	0	0	0					
9	8-bit character	0	0	1	0	0	Single screen	Character	8-bit	Normal	OR
		0	0	1	0	1				AT	
10	8-bit wide character	0	0	1	1	0				Wide	OR
		0	0	1	1	1	AT				
11	8-bit graphic 1	0	1	1	0	1	Graphic	—	—	—	
12	8-bit graphic 2	0	1	1	0	0					
13	Large screen	1	1	1	0	1	Dual screen	4-bit × 2	—	—	

The LCTC display mode is determined by pins D/ $\bar{S}$  (pin 55), G/ $\bar{C}$  (pin 58), LS (pin 56), WIDE (pin 54), and AT (pin 57). As for G/C, WIDE, and AT, the OR is taken between data bits 0, 2, and 3 of the mode register (R22). The display mode can be controlled by either one of the external pins or the data bits of R22.

Note: The above 5 pins have 32 status combinations (high and low). Any combinations other than the above are prohibited, because they may cause malfunctions. If you set an prohibited combination, set the right combination again.

HITACHI

■ 4496204 0046759 644 ■

**Internal Registers**

The HD63645/HD64645/HD64646 has one address register and fourteen data registers. In order to select one out of fourteen data registers, the address of the data register to be selected must be written into the address register. The MPU can transfer data to/from the data register corresponding to the written address.

To be software compatible with the CRTC (HD6845), registers R2-R8, R16, and R17, which are not necessary for an LCD are defined as invalid for the LCTC.

**Address Register (AR)**

AR register (figure 23) specifies one out of 14 data registers. Address data is written into the address register when RS is low. If no register corresponding to a specified address exists, the address data is invalid.

**Horizontal Total Characters Register (R0)**

R0 register (figure 24) specifies a horizontal scanning period. The total number of horizontal characters less 1 must be programmed into this 8-bit register in character units. Nht indicates the horizontal scanning period including the period when the CPU occupies memory (total number of horizontal characters minus the number of horizontal displayed characters). Its units are, then, converted from time into the number of characters. This value should be specified according to the specification of the LCD system to be used.

Note the following restrictions

$$Nhd + \frac{16}{m} \leq Nht + 1$$

Mode No.	m
5, 9	1
1, 6, 7, 8, 10, 11, 12, 13	2
2, 3, 4	4

**Horizontal Displayed Characters Register (R1)**

R1 register (figure 25) specifies the number of characters displayed per row. The horizontal character pitches are 8 bits for normal character display and 16 dots for wide character display and graphic display.

Nhd must be less than the total number of horizontal characters.

**Maximum Raster Address Register (R9)**

R9 register (figure 26) specifies the number of rasters per row in characters mode, consisting of 5 bits. The programmable range is 0 (1 raster/row) to 31 (32 rasters/row).

**Cursor Start Raster Register (R10)**

R10 register (figure 27) specifies the cursor start raster address and its blink mode. Refer to table 11.

Data Bit								Program Unit	R/W
7	6	5	4	3	2	1	0	—	W
Register address									

Figure 23 Address Register

Data Bit								Program Unit	R/W
7	6	5	4	3	2	1	0	Character	W
Nhd (Displayed characters)									

Figure 25 Horizontal Displayed Characters Register

Data Bit								Program Unit	R/W
7	6	5	4	3	2	1	0	Character	W
Nht (Total characters - 1)									

Figure 24 Horizontal Total Characters Register

Data Bit								Program Unit	R/W
7	6	5	4	3	2	1	0	Raster	W
Nr									

Figure 26 Maximum Raster Address Register

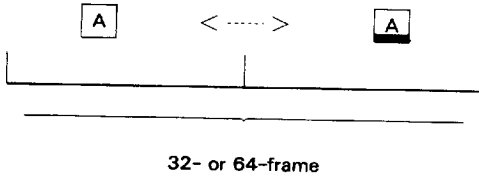

**Cursor End Raster Register (R11)**

R11 register (figure 28) specifies the cursor end raster address.

**Start Address Register (H/L)(R12/R13)**

R12/R13 register (figure 29) specifies a buffer memory read start address. Updating this register facilitates paging and scrolling. R14/R15 register can be read and written to/from the MPU.

**Cursor Address Register (H/L)(R14/R15)**

R14/R15 register (figure 30) specifies a cursor display address. Cursor display requires setting R10 and R11, and CUDISP should be connected with MD12 (in character mode). This register can be read from and written to the MPU.

**Horizontal Virtual Screen Width Register (R18)**

R18 register (figure 31) specifies the memory width to determine the start address of the next row. By using this register, memory width can be specified larger than the number of horizontal displayed characters. Updating the display start address facilitates scrolling in any direction within a memory space.

The start address of the next row is that of the previous row plus Nir. If a larger memory width than display width is unnecessary, Nir should be set equal to the number of horizontal displayed characters.

**Multiplexing Duty Ratio Register (H/L)(R19/R20)**

R19/R20 register (figure 32) specifies the number of vertical dots of the display screen. The programmed value differs according to the LCD screen configuration.

In single screen configuration :

$$(\text{Programmed value}) = (\text{Number of vertical dots}) - 1.$$

**Table 11 Cursor Blink Mode**

B	P	Cursor blink mode
0	0	Cursor on; without blinking
0	1	Cursor off
1	0	Blinking once every 32 frames
1	1	Blinking once every 64 frames

Data Bit								Program Unit	R/W
7	6	5	4	3	2	1	0	Raster	W
—	B	P	Ncs (Raster address)						

**Figure 27 Cursor Start Raster Register**

Data Bit								Program Unit	R/W
7	6	5	4	3	2	1	0	Raster	W
—	—	—	Nce (Raster address)						

**Figure 28 Cursor End Raster Register**

Data Bit								Program Unit	R/W
7	6	5	4	3	2	1	0	Memory address	R/W
Memory address (H) (R12)									
Memory address (L) (R13)								Memory address	R/W

**Figure 29 Start Address Register**

Data Bit								Program Unit	R/W
7	6	5	4	3	2	1	0	Memory address	R/W
Memory address (H) (R14)									
Memory address (L) (R15)								Memory address	R/W

**Figure 30 Cursor Address Register**

In dual screen configuration :

$$\text{(Programmed value)} = \frac{\text{(Number of vertical dots)}}{2} - 1.$$

**Display Start Raster Register (R21)**

R21 register (figure 33) specifies the start raster of the character row displayed on the top of the screen. The programmed value

should be equal or less than the maximum raster address. Updating this register allows smooth scrolling in character mode.

**Mode Register (R22)**

The Or of the data bits of R22 (figure 34) register and the external terminals of the same name determines a particular mode. (figure 35)

Data Bit								Program Unit	R/W
7	6	5	4	3	2	1	0	Character	W
Nir (No. of chars. of virtual width)									

**Figure 31 Horizontal Virtual Screen Width Register**

Data Bit								Program Unit	R/W
7	6	5	4	3	2	1	0	Raster	W
Raster address									

**Figure 33 Display Start Raster Register**

Data Bit								Program Unit	R/W
7	6	5	4	3	2	1	0	Raster	W
Ndh* (R19)									
Ndl (Number of rasters - 1) (R20)									

\* : Number of rasters

**Figure 32 Multiplexing Duty Ratio Register**

Data Bit								Program Unit	R/W
7	6	5	4	3	2	1	0	—	W
ON/OFF G/C WIDE BLE AT									

**Figure 34 Mode Register**

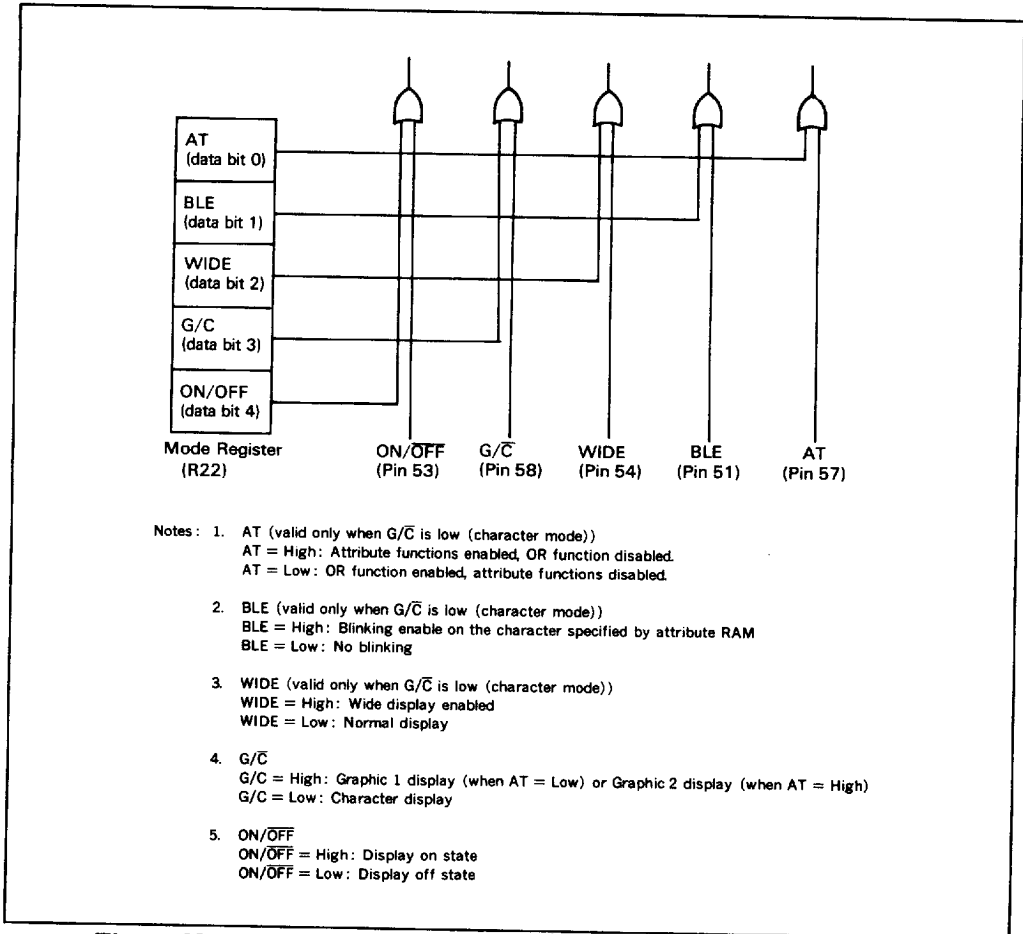

**Figure 35 Correspondence between Mode Register and External Pins**

HITACHI

967

■ 4496204 0046763 075 ■

**Restrictions on Programming Internal Registers**

Note when programming that the values you can write into the internal registers are restricted as shown in Table 12.

**Table 12 Restrictions on Writing Values into the Internal Registers**

Function	Restrictions	Register
Display Format	$1 < Nhd < Nht + 1 \leq 256$	R0, R1
	$Nhd + \frac{16}{m} * 1 \leq Nht + 1$	
	(No. of vertical dots) x (no. of horizontal dots) x (frame frequency; $f_{FRM}$ ) $\leq$ (data transfer speed; V)	R1, R19, R20
	$\left\{ \begin{matrix} 1 \\ 2 \end{matrix} \right\} * 2 \times (Nd + 1) \times Nhd \times \left\{ \begin{matrix} 8 \\ 16 \end{matrix} \right\} * 3 f_{FRM} \leq V$	
	$Nhd \leq Nir$	R1, R18
	$0 \leq Nd \leq 511$	R19, R20
Cursor Control	$0 \leq Ncs \leq Nce$	R10, R11
	$Nce \leq Nr$	R10, R9
Smooth Scroll	$Nsr \leq Nr$	R21, R9
Memory Width Set	$0 \leq Nir \leq 255$	R18

Notes' \*1 m varies according to the modes. See the following table.

Mode No.	m
5,9	1
1,6,7,8,10,11,12,13	2
2,3,4	4

\*2 Set 1 when an LCD screen is a single screen, and set 2 when dual. Modes are classified as shown in the following table.

Mode No.	Value
5,6,7,8,9,10,11,12	1
1,2,3,4,13	2

\*3 Set 8 when a character is constructed with 8 dots, and set 16 when with 16 dots. Modes are classified as shown in the following table.

Mode No.	Value
1,5,9	8
2,3,4,6,7,8,10,11,12,13	16

**Reset**

$\overline{\text{RES}}$  pin determines the internal state of LSI counters and the like. This pin does not affect register contents nor does it basically control output terminals.

Reset is defined as follows (Figure 36):

- At reset: the time when  $\overline{\text{RES}}$  goes low
- During reset: the period while  $\overline{\text{RES}}$  remains low
- After reset: the period on and after the  $\overline{\text{RES}}$  transition from low to high
- Make sure to hold the reset signal low for at least 1  $\mu\text{s}$

$\overline{\text{RES}}$  pin should be pulled high by users during operation.

**Reset State of Pins**

$\overline{\text{RES}}$  pin does not basically control output pins, and operates regardless of other input pins.

1. Preserve states before reset:  
LU0-LU3, LD0-LD3, FLM, CL1, RA0-RA4

2. Fixed at high level:  
MLCK
3. Preserve states before reset or fixed at low level according to the timing when the reset signal is input:  
DISPTMG, CUDISP, MA0-MA15
4. Fixed at high or low according to mode:  
CL2
5. Unaffected:  
DB<sub>0</sub>-DB<sub>7</sub>

**Reset State of Registers**

$\overline{\text{RES}}$  pin does not affect register contents. Therefore, registers can be read or written even during a reset state; their contents will be preserved regardless of reset until they are rewritten to.

**Notes for HD63645/HD64645/HD64646**

1. The HD63645/HD64645/HD64646 are CMOS LSIs, and it should be noted that input pins must not be left disconnected, etc.
2. At power-on, the state of internal registers becomes undefined. The LSI operation is undefined until all internal registers have been programmed.

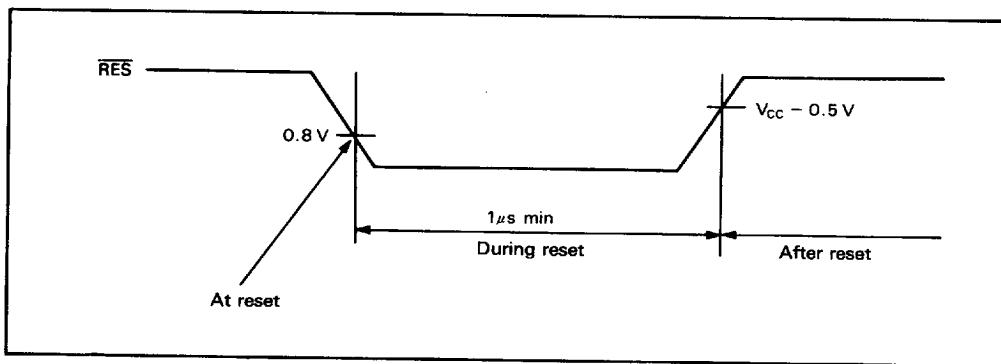

**Figure 36 Reset Definition**

**Absolute Maximum Ratings**

Item	Symbol	Value	Note
Supply voltage	V <sub>CC</sub>	-0.3 to +7.0 V	2
Terminal voltage	V <sub>in</sub>	-0.3 to V <sub>CC</sub> +0.3 V	2
Operating temperature	T <sub>opr</sub>	-20°C to +75°C	
Storage temperature	T <sub>stg</sub>	-55°C to +125°C	

- Notes: 1. Permanent LSI damage may occur if maximum ratings are exceeded. Normal operation should be under recommended operating conditions (V<sub>CC</sub> = 5.0 V ±10%, GND = 0 V, T<sub>a</sub> = -20°C to +75°C). If these conditions are exceeded, it could affect reliability of LSI.  
 2. With respect to ground (GND = 0 V)

**Electrical Characteristics**

**DC Characteristics** (V<sub>CC</sub> = 5.0 V ±10%, GND = 0 V, T<sub>a</sub> = -20°C to +75°C, unless otherwise noted)

Item	Symbol	Min	Typ	Max	Unit	Test Condition
Input high voltage	RES, MODE, SK0, V <sub>IH</sub>	V <sub>CC</sub> -0.5		V <sub>CC</sub> +0.3	V	
	SK1					
	DCLK, ON/OFF	2.2		V <sub>CC</sub> +0.3	V	
	All others	2.0		V <sub>CC</sub> +0.3	V	
Input low voltage	All others	V <sub>IL</sub>	-0.3	0.8	V	
Output high voltage	TTL interface <sup>1</sup>	V <sub>OH</sub>	2.4		V	I <sub>OH</sub> = -400μA
	CMOS interface <sup>1</sup>		V <sub>CC</sub> -0.8		V	I <sub>OH</sub> = -400μA
Output low voltage	TTL interface	V <sub>OL</sub>		0.4	V	I <sub>OL</sub> = 1.6mA
	CMOS interface			0.8	V	I <sub>OL</sub> = 400μA
Input leakage current	All inputs except DB <sub>0</sub> -DB <sub>7</sub>	I <sub>IL</sub>	-2.5	+2.5	μA	
Three state (off-state) leakage current	DB <sub>0</sub> -DB <sub>7</sub>	I <sub>TSL</sub>	-10	+10	μA	
Current dissipation <sup>2</sup>	I <sub>CC</sub>			10	mA	

- Notes: 1. TTL Interface; MA0-MA15, RA0-RA4, DISPTMG, CUDISP, DB0-DB7, MCLK C-MOS Interface; LU0-LU3, LD0-LD3, CL1, CL2, M, FLM  
 2. Input/output current is excluded. When input is at the intermediate level with CMOS, excessive current flows through the input circuit to power supply. Input level must be fixed at high or low to avoid this condition.  
 3. If the capacitive loads of LU0-LU3 and LD0-LD3 exceed the rating, noise over 0.8 V may be produced on CUDISP, DISPTMG, MCLK, FLM and M. In case the loads of LU0-LU3 and LD0-LD3 are larger than the ratings, supply signals to the LCD module through buffers.

**AC Characteristics**

**CPU Interface (HD63645 — 68 family)**

( $V_{CC} = 5.0\text{ V} \pm 10\%$ ,  $GND = 0\text{ V}$ ,  $T_a = -20^\circ\text{C}$  to  $+75^\circ\text{C}$ , unless otherwise noted)

Item	Symbol	Min	Typ	Max	Unit	Figure
Enable cycle time	$t_{CYCE}$	500			ns	37
Enable pulse width (high)	$P_{WEH}$	220			ns	
Enable pulse width (low)	$P_{WEL}$	220			ns	
Enable rise time	$t_{Er}$			25	ns	
Enable fall time	$t_{Ef}$			25	ns	
$\overline{CS}$ , RS, R/ $\overline{W}$ setup time	$t_{AS}$	70			ns	
$\overline{CS}$ , RS, R/ $\overline{W}$ hold time	$t_{AH}$	10			ns	
DB <sub>0</sub> -DB <sub>7</sub> setup time	$t_{DS}$	60			ns	
DB <sub>0</sub> -DB <sub>7</sub> hold time	$t_{DHW}$	10			ns	
DB <sub>0</sub> -DB <sub>7</sub> output delay time	$t_{DDR}$			150	ns	
DB <sub>0</sub> -DB <sub>7</sub> output hold time	$t_{DHR}$	20			ns	

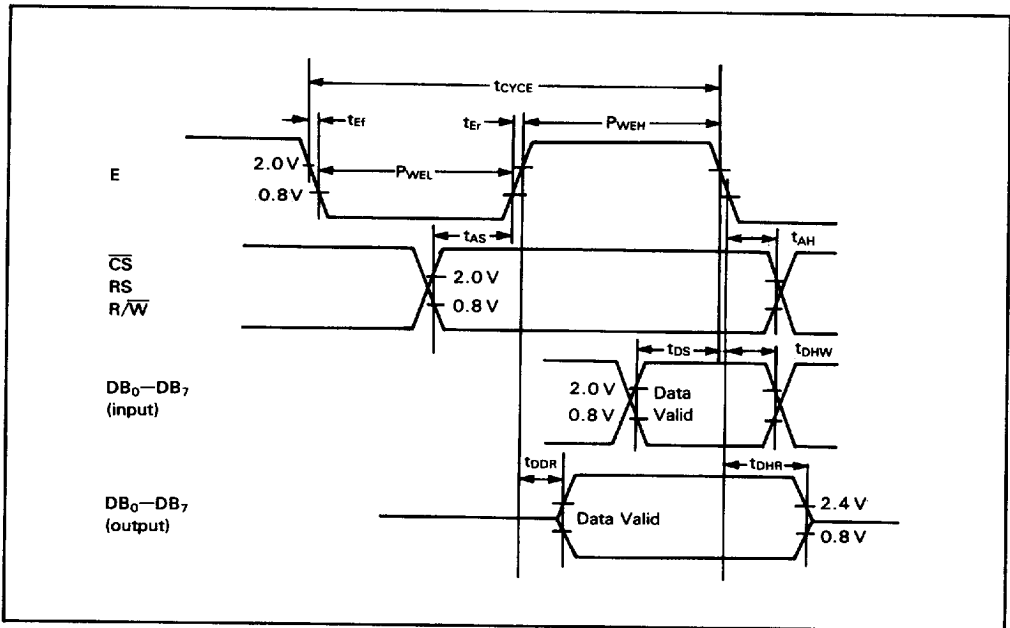

**Figure 37 CPU Interface (HD63645)**

**HITACHI**

4496204 0046767 710

# HD63645/HD64645/HD64646

**CPU Interface (HD64645 and HD64646 — 80 family)**  
 ( $V_{CC} = 5.0\text{ V} \pm 10\%$ ,  $GND = 0\text{ V}$ ,  $T_a = -20^\circ\text{C}$  to  $+75^\circ\text{C}$ , unless otherwise noted)

Item	Symbol	Min	Typ	Max	Unit	Figure
RD high level width	$t_{WRDH}$	190			ns	38
RD low level width	$t_{WRDL}$	190			ns	
WR high level width	$t_{WWRH}$	190			ns	
WR low level width	$t_{WWRL}$	190			ns	
CS, RS setup time	$t_{AS}$	0			ns	
CS, RS hold time	$t_{AH}$	0			ns	
DB <sub>0</sub> -DB <sub>7</sub> setup time	$t_{DSW}$	100			ns	
DB <sub>0</sub> -DB <sub>7</sub> hold time	$t_{DHW}$	0			ns	
DB <sub>0</sub> -DB <sub>7</sub> output delay time	$t_{DDR}$			150	ns	
DB <sub>0</sub> -DB <sub>7</sub> output hold time	$t_{DHR}$	20			ns	

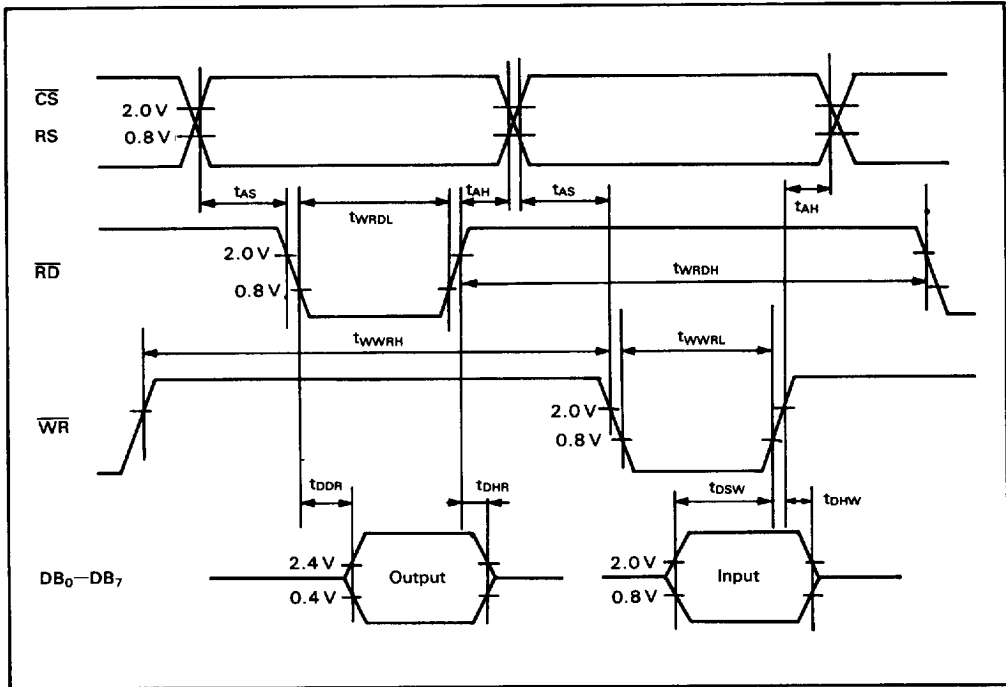

**Figure 38 CPU Interface (HD64645 and HD64646)**

**AC Characteristics (Cont)**

**Memory Interface**

( $V_{CC} = 5.0\text{ V} \pm 10\%$ ,  $GND = 0\text{ V}$ ,  $T_a = -20^\circ\text{C}$  to  $+75^\circ\text{C}$ , unless otherwise noted)

Item	Symbol	Min	Typ	Max	Unit	Figure
DCLK cycle time	$t_{CYCD}$	100	—	—	ns	39
DCLK high level width	$t_{WDH}$	30	—	—	ns	
DCLK low level width	$t_{WDL}$	30	—	—	ns	
DCLK rise time	$t_{Dr}$	—	—	20	ns	
DCLK fall time	$t_{Df}$	—	—	20	ns	
MCLK delay time	$t_{DMD}$	—	—	60	ns	
MCLK rise time	$t_{Mr}$	—	—	30	ns	
MCLK fall time	$t_{Mf}$	—	—	30	ns	
MA0-MA15 delay time	$t_{MAD}$	—	—	150	ns	
MA0-MA15 hold time	$t_{MAH}$	10	—	—	ns	
RA0-RA4 delay time	$t_{RAD}$	—	—	150	ns	
RA0-RA4 hold time	$t_{RAH}$	10	—	—	ns	
DISPTMG delay time	$t_{DPTD}$	—	—	150	ns	
DISPTMG hold time	$t_{DPTH}$	10	—	—	ns	
CUDISP delay time	$t_{CDD}$	—	—	150	ns	
CUDISP hold time	$t_{CDH}$	10	—	—	ns	
CL1 delay time	$t_{CL1D}$	—	—	150	ns	
CL1 hold time	$t_{CL1H}$	10	—	—	ns	
CL1 rise time	$t_{CL1r}$	—	—	50	ns	
CL1 fall time	$t_{CL1f}$	—	—	50	ns	
MDO-MD15 setup time	$t_{MDS}$	30	—	—	ns	
MDO-MD15 hold time	$t_{MDH}$	15	—	—	ns	

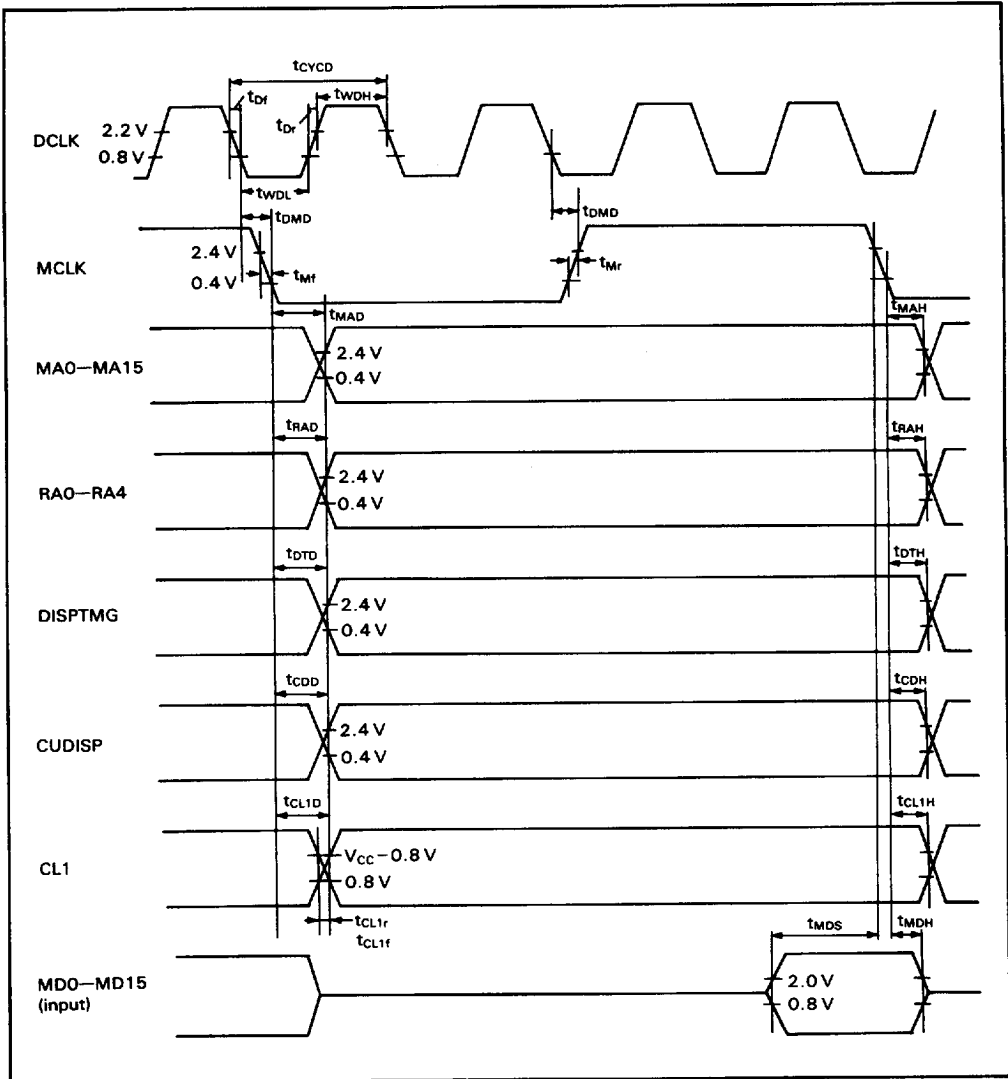

Figure 39 Memory Interface

**AC Characteristics (Cont)**

**LCD Interface 1 (HD63645 and HD64645)**  
 ( $V_{CC} = 5.0\text{ V} \pm 10\%$ ,  $GND = 0\text{ V}$ ,  $T_a = -20^\circ\text{C}$  to  $+75^\circ\text{C}$ )

Item	Symbol	Min	Typ	Max	Unit	Figure
Display data setup time	$t_{LDS}$	50	—	—	ns	40
Display data hold time	$t_{LDH}$	100	—	—	ns	
CL2 high level width	$t_{WCL2H}$	100	—	—	ns	
CL2 low level width	$t_{WCL2L}$	100	—	—	ns	
FLM setup time	$t_{FS}$	500	—	—	ns	
FLM hold time	$t_{FH}$	300	—	—	ns	
CL1 rise time	$t_{CL1r}$	—	—	50	ns	
CL1 fall time	$t_{CL1f}$	—	—	50	ns	
CL2 rise time	$t_{CL2r}$	—	—	50	ns	
CL2 fall time	$t_{CL2f}$	—	—	50	ns	

Note : At  $f_{CL2} = 3\text{ MHz}$

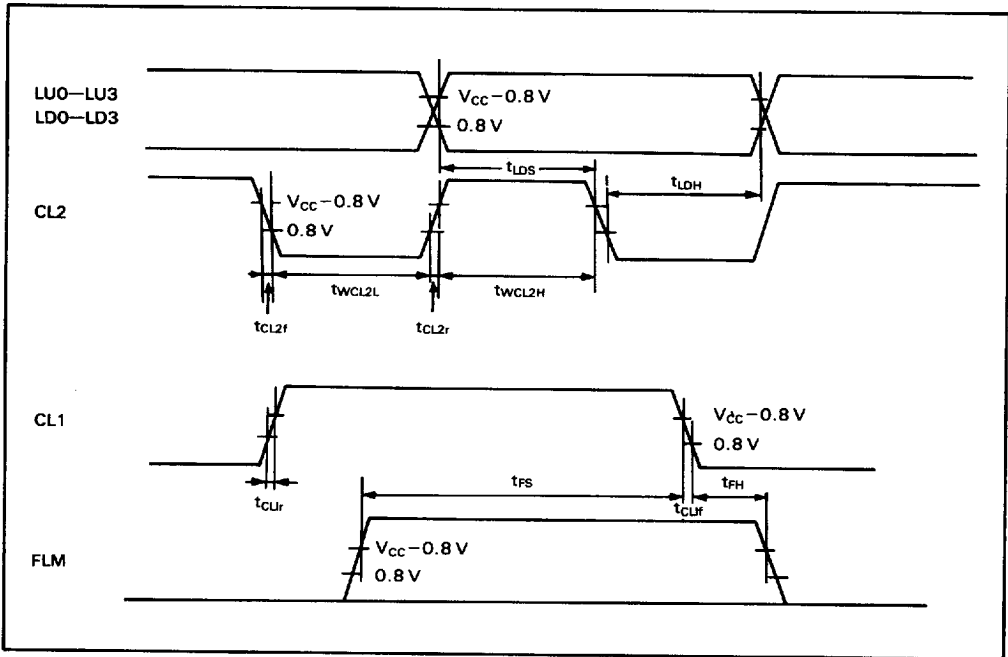

**Figure 40 LCD Interface**

**AC Characteristics (Cont)**

**LCD Interface 2 (HD64646 at  $f_{CL2} = 3 \text{ MHz}$ )**  
 ( $V_{CC} = 5.0 \text{ V} \pm 10\%$ ,  $GND = 0 \text{ V}$ ,  $T_a = -20^\circ\text{C}$  to  $+75^\circ\text{C}$ )

Item	Symbol	Min	Typ	Max	Unit	Figure
FLM setup time	$t_{Fs}$	500	—	—	ns	41
FLM hold time	$t_{FH}$	300	—	—	ns	
M delay time	$t_{DM}$	—	—	200	ns	
CL1 high level width	$t_{CL1H}$	300	—	—	ns	
Clock setup time	$t_{SCL}$	500	—	—	ns	
Clock hold time	$t_{HCL}$	100	—	—	ns	
Phase difference 1	$t_{PD1}$	100	—	—	ns	
Phase difference 2	$t_{PD2}$	500	—	—	ns	
CL2 high level width	$t_{CL2H}$	100	—	—	ns	
CL2 low level width	$t_{CL2L}$	100	—	—	ns	
CL2 rise time	$t_{CL2r}$	—	—	50	ns	
CL2 fall time	$t_{CL2f}$	—	—	50	ns	
Display data setup time	$t_{LDS}$	80	—	—	ns	
Display data hold time	$t_{LDH}$	100	—	—	ns	
Display data delay time	$t_{LDD}$	—	—	30	ns	

**LCD Interface 3 (HD64646 at  $f_{CL2} = 5 \text{ MHz}$ )**  
 ( $V_{CC} = 5.0 \text{ V} \pm 10\%$ ,  $GND = 0 \text{ V}$ ,  $T_a = -20^\circ\text{C}$  to  $+75^\circ\text{C}$ )

Item	Symbol	Min	Typ	Max	Unit	Figure
FLM setup time	$t_{Fs}$	500	—	—	ns	41
FLM hold time	$t_{FH}$	500	—	—	ns	
M delay time	$t_{DM}$	—	—	200	ns	
CL1 high level width	$t_{CL1H}$	300	—	—	ns	
Clock setup time	$t_{SCL}$	500	—	—	ns	
Clock hold time	$t_{HCL}$	100	—	—	ns	
Phase difference 1	$t_{PD1}$	70	—	—	ns	
Phase difference 2	$t_{PD2}$	500	—	—	ns	
CL2 high level width	$t_{CL2H}$	50	—	—	ns	
CL2 low level width	$t_{CL2L}$	50	—	—	ns	
CL2 rise time	$t_{CL2r}$	—	—	50	ns	
CL2 fall time	$t_{CL2f}$	—	—	50	ns	
Display data setup time	$t_{LDS}$	30	—	—	ns	
Display data hold time	$t_{LDH}$	30	—	—	ns	
Display data delay time	$t_{LDD}$	—	—	30	ns	

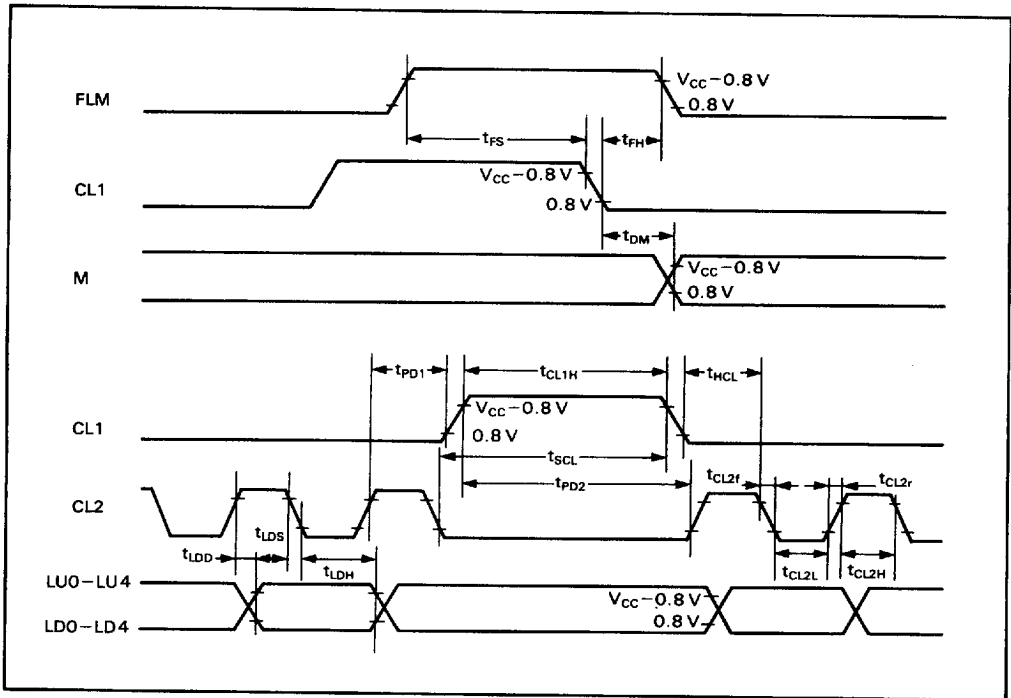

Figure 41 LCD Interface

# HD63645/HD64645/HD64646

## AC Characteristics

### TTL Load

Terminal	R <sub>L</sub>	R	C	Remarks
DB <sub>0</sub> -DB <sub>7</sub>	2.4 kΩ	11 kΩ	130 pF	tr, tf: Not specified
MA0-MA15, RA0-RA4, DISPTMG, CUDISP	2.4 kΩ	11kΩ	40 pF	
MCLK	2.4 kΩ	11 kΩ	30 pF	tr, tf: Specified

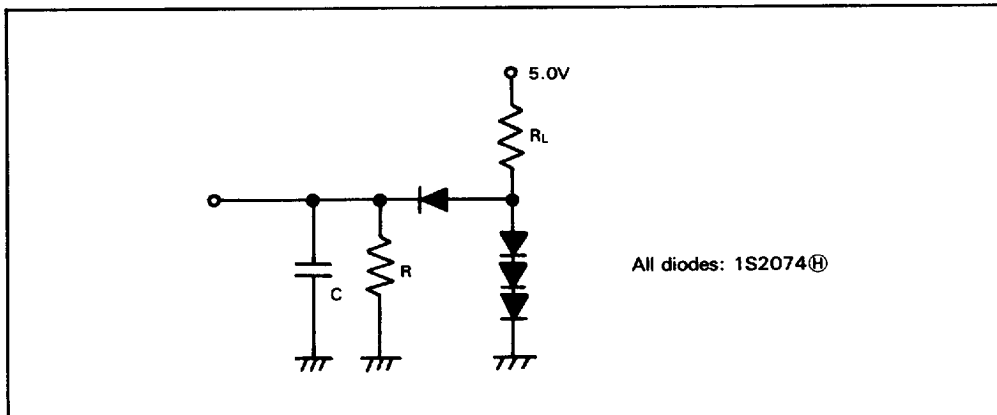

### Capacitive Load

Terminal	C	Remarks
CL2	150 pF	tr, tf: Specified
CL1	200 pF	
LU0-LU3, LD0-LD3, M	150 pF	tr, tf: Not specified
FLM	50 pF	

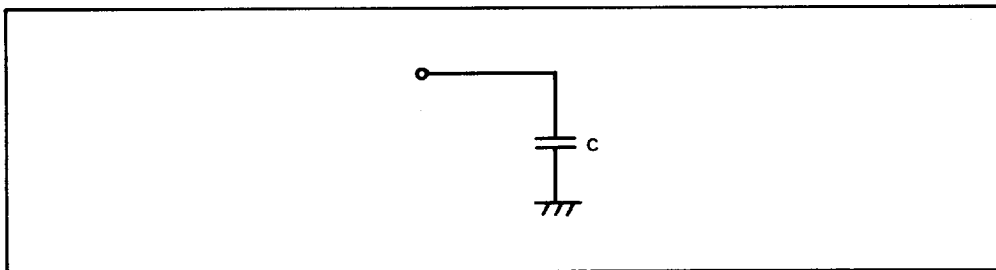

Refer to user's manual (No. 68-1-160) and application note (No. ADE-502-003) for detail of this product.