

Section 15. Electrical Specifications

15.1 Absolute Maximum Ratings

Table 15-1 lists the absolute maximum ratings.

Table 15-1. Absolute Maximum Ratings

Item	Symbol	Rating	Unit
Supply voltage	V _{CC}	-0.3 to +7.0	V
Programming voltage	V _{PP}	-0.3 to +14.0	V
Input voltage	V _{in}	-0.3 to V _{CC} + 0.3	V
Operating temperature	T _{opr}	Regular specifications: -20 to +75	°C
		Wide-range specifications: -40 to +85	°C
Storage temperature	T _{stg}	-55 to +125	°C

Note: The input pins have protection circuits that guard against high static voltages and electric fields, but these high input-impedance circuits should never receive overvoltages exceeding the absolute maximum ratings shown in table 15-1.

15.2 Electrical Characteristics

15.2.1 DC Characteristics

Table 15-2 lists the DC characteristics of the H8/325 series.

Table 15-2. DC Characteristics

Conditions: $V_{CC} = 5.0V \pm 10\%$, $V_{SS} = 0V$, $T_a = -20$ to $75^\circ C$ (regular specifications)

$T_a = -40$ to $85^\circ C$ (wide-range specifications)

Item	Symbol	min	typ	max	Unit	Measurement	
						conditions	
Schmitt trigger	P66 – P63, P60,	V_{T^-}	1.0	–	–	V	
input voltage	P70	V_{T^+}	–	–	$V_{CC} \times 0.7$	V	
(1)		$V_{T^+} - V_{T^-}$	0.4	–	–	V	
Input high voltage	\overline{RES} , \overline{STBY}	V_{IH}	$V_{CC} - 0.7$	–	$V_{CC} + 0.3$	V	
(2)	MD1, MD0 EXTAL, \overline{NMI}						
Input high voltage	Input pins	V_{IH}	2.0	–	$V_{CC} + 0.3$	V	
	other than (1) and (2)						
Input low voltage	\overline{RES} , \overline{STBY}	V_{IL}	–0.3	–	0.5	V	
(3)	MD1, MD0, EXTAL						
Input low voltage	Input pins	V_{IL}	–0.3	–	0.8	V	
	other than (1) and (3)						
Output high	All output pins	V_{OH}	$V_{CC} - 0.5$	–	–	V	$I_{OH} = -200 \mu A$
voltage			3.5	–	–	V	$I_{OH} = -1.0 mA$
Output low	All output pins	V_{OL}	–	–	0.4	V	$I_{OL} = 1.6 mA$
voltage	P17 – P10, P27 – P20		–	–	1.0	V	$I_{OL} = 10.0 mA$
Input leakage	\overline{RES}	I_{inl}	–	–	10.0	μA	$V_{in} = 0.5 V$ to
current	\overline{STBY} , \overline{NMI} , MD1, MD0		–	–	1.0	μA	$V_{CC} - 0.5 V$
Leakage current	Ports 1 to 7	I_{Tsil}	–	–	1.0	μA	$V_{in} = 0.5 V$ to
in 3-state (off state)							$V_{CC} - 0.5 V$
Input pull-up	Ports 1 to 7	$-I_p$	30	–	250	μA	$V_{in} = 0 V$
MOS current							

Table 15-2. DC Characteristics (cont.)Conditions: $V_{CC} = AV_{CC} = 5.0V \pm 10\%$, $V_{SS} = 0V$, $T_a = -20$ to $75^\circ C$ (regular specifications) $T_a = -40$ to $85^\circ C$ (wide-range specifications)

Item		Symbol	min	typ	max	Unit	Measurement conditions
Input capacitance	\overline{RES}	C_{in}	–	–	60	pF	$V_{in} = 0 V$
	\overline{NMI}			–	30	pF	
	All input pins except \overline{RES} and \overline{NMI}			–	15	pF	
Current dissipation*1	Normal operation	I_{CC}	–	12	25	mA	$f = 6 MHz$
				16	30	mA	$f = 8 MHz$
				20	40	mA	$f = 10 MHz$
	Sleep mode			8	15	mA	$f = 6 MHz$
				10	20	mA	$f = 8 MHz$
				12	25	mA	$f = 10 MHz$
Standby modes*2	–	0.01	5.0	μA			
RAM standby voltage		V_{RAM}	2.0	–	–	V	

Notes: 1. Current dissipation values assume that $V_{IH \text{ min.}} = V_{CC} - 0.5V$, $V_{IL \text{ max.}} = 0.5V$, all output pins are in the no-load state, and all MOS input pull-ups are off.2. For these values it is assumed that $V_{RAM} \leq V_{CC} < 4.5 V$ and $V_{IH \text{ min.}} = V_{CC} \times 0.9$, $V_{IL \text{ max.}} = 0.3 V$.

Table 15-3. Allowable Output Current Sink Values

Conditions: $V_{CC} = 5.0V \pm 10\%$, $V_{SS} = 0V$, $T_a = -20$ to $75^\circ C$ (regular specifications)

$T_a = -40$ to $85^\circ C$ (wide-range specifications)

Item		Symbol	min	typ	max	Unit
Allowable output low current sink (per pin)	Ports 1 and 2	I_{OL}	–	–	10	mA
	Other output pins		–	–	2.0	mA
Allowable output low current sink (total)	Ports 1 and 2, total	ΣI_{OL}	–	–	80	mA
	All output pins		–	–	120	mA
Allowable output high current sink (per pin)	All output pins	$-I_{OH}$	–	–	2.0	mA
Allowable output high current sink (total)	Total of all output	$\Sigma -I_{OH}$	–	–	40	mA

Note: To avoid degrading the reliability of the chip, be careful not to exceed the output current sink values in table 15-3. In particular, when driving a Darlington pair or LED directly, be sure to insert a current-limiting resistor in the output path. See figures 17-1 and 17-2.

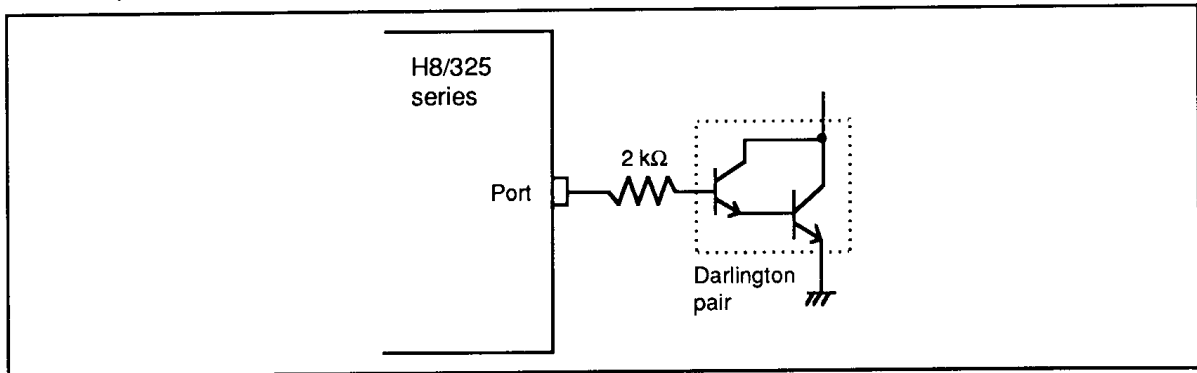

Figure 15-1. Example of Circuit for Driving a Darlington Pair

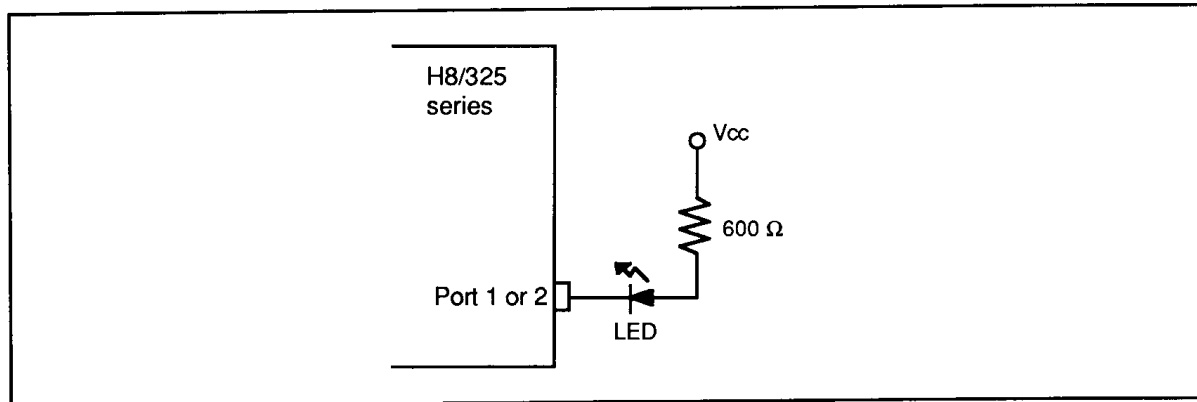

Figure 15-2. Example of Circuit for Driving a LED

15.2.2 AC Characteristics

The AC characteristics of the H8/325 series are listed in three tables. Bus timing parameters are given in table 15-4, control signal timing parameters in table 15-5, and timing parameters of the on-chip supporting modules in table 15-6.

Table 15-4. Bus Timing

Conditions: $V_{CC} = 5.0V \pm 10\%$, $\emptyset = 0.5$ to 10MHz, $V_{SS} = 0V$,

$T_a = -20$ to $75^\circ C$ (regular specifications), $T_a = -40$ to $85^\circ C$ (wide-range specifications)

Measurement Item	Symbol	Measurement conditions	6MHz		8MHz		10MHz		Unit
			min	max	min	max	min	max	
Clock cycle time	t _{cy}	Fig. 15-4	166.7	2000	125	2000	100	2000	ns
Clock pulse width Low	t _{CL}	Fig. 15-4	65	–	45	–	35	–	ns
Clock pulse width High	t _{CH}	Fig. 15-4	65	–	45	–	35	–	ns
Clock rise time	t _{Cr}	Fig. 15-4	–	15	–	15	–	15	ns
Clock fall time	t _{Cf}	Fig. 15-4	–	15	–	15	–	15	ns
Address delay time	t _{AD}	Fig. 15-4	–	70	–	60	–	55	ns
Address hold time	t _{AH}	Fig. 15-4	30	–	25	–	20	–	ns
Address strobe delay time	t _{ASD}	Fig. 15-4	–	70	–	60	–	40	ns
Write strobe delay time	t _{WSD}	Fig. 15-4	–	70	–	60	–	50	ns
Strobe delay time	t _{SD}	Fig. 15-4	–	70	–	60	–	50	ns
Write strobe pulse width	t _{WSW}	Fig. 15-4	200	–	150	–	120	–	ns
Address setup time 1	t _{AS1}	Fig. 15-4	25	–	20	–	15	–	ns
Address setup time 2	t _{AS2}	Fig. 15-4	105	–	80	–	65	–	ns
Read data setup time	t _{RDS}	Fig. 15-4	60	–	50	–	35	–	ns
Read data hold time	t _{RDH}	Fig. 15-4	0	–	0	–	0	–	ns
Write data delay time	t _{WDD}	Fig. 15-4	–	85	–	75	–	75	ns
Read data access time	t _{ACC}	Fig. 15-4	–	280	–	210	–	170	ns
Write data setup time	t _{WDS}	Fig. 15-4	30	–	15	–	10	–	ns
Write data hold time	t _{WDH}	Fig. 15-4	30	–	25	–	20	–	ns
Wait setup time	t _{WTS}	Fig. 15-5	45	–	45	–	45	–	ns
Wait hold time	t _{WTH}	Fig. 15-5	10	–	10	–	10	–	ns
E clock delay time	t _{ED}	Fig. 15-6	–	25	–	25	–	25	ns
E clock rise time	t _{Er}	Fig. 15-6	–	15	–	15	–	15	ns
E clock fall time	t _{Ef}	Fig. 15-6	–	15	–	15	–	15	ns
Read data hold time (for E clock)	t _{RDHE}	Fig. 15-6	0	–	0	–	0	–	ns
Write data hold time (for E clock)	t _{WDHE}	Fig. 15-6	50	–	40	–	30	–	ns

Table 15-5. Control Signal TimingConditions: $V_{CC} = 5.0V \pm 10\%$, $\phi = 0.5$ to 10 MHz, $V_{SS} = 0V$, $T_a = -20$ to $75^\circ C$ (regular specifications), $T_a = -40$ to $85^\circ C$ (wide-range specifications)

Measurement Item	Symbol	Measurement conditions	6MHz		8MHz		10MHz		Unit
			min	max	min	max	min	max	
\overline{RES} setup time	tRESS	Fig. 15-7	200	–	200	–	200	–	ns
\overline{RES} pulse width	tRESW	Fig. 15-7	10	–	10	–	10	–	t _{cy}
Mode programming setup time	tMDS	Fig. 15-7	4	–	4	–	4	–	t _{cy}
\overline{NMI} setup time (\overline{NMI} , $\overline{IRQ0}$ to $\overline{IRQ2}$)	tNMIS	Fig. 15-8	150	–	150	–	150	–	ns
\overline{NMI} hold time (\overline{NMI} , $\overline{IRQ0}$ to $\overline{IRQ2}$)	tNMIH	Fig. 15-8	10	–	10	–	10	–	ns
Interrupt pulse width for recovery from soft- ware standby mode (\overline{NMI} , $\overline{IRQ0}$ to $\overline{IRQ2}$)	tNMIW	Fig. 15-8	200	–	200	–	200	–	ns
Crystal oscillator settling time (reset)	tosc1	Fig. 15-9	20	–	20	–	20	–	ms
Crystal oscillator settling time (software standby)	tosc2	Fig. 15-10	10	–	10	–	10	–	ms

Table 15-6. Timing Conditions of On-Chip Supporting ModulesConditions: $V_{CC} = 5.0V \pm 10\%$, $\phi = 0.5$ to 10MHz, $V_{SS} = 0V$, $T_a = -20$ to $75^\circ C$ (regular specifications), $T_a = -40$ to $85^\circ C$ (wide-range specifications)

Item	Symbol	Measurement conditions	6MHz		8MHz		10MHz		Unit
			min	max	min	max	min	max	
FRT Timer output delay time	tFTOD	Fig. 15-11	–	100	–	100	–	100	ns
Timer input setup time	tFTIS	Fig. 15-11	50	–	50	–	50	–	ns
Timer clock input setup time	tFTCS	Fig. 15-12	50	–	50	–	50	–	ns
Timer clock pulse width	tFTCWH tFTCWL	Fig. 15-12	1.5	–	1.5	–	1.5	–	t _{cy}

Table 15-6. Timing Conditions of On-Chip Supporting Modules (cont.)Conditions: $V_{CC} = 5.0V \pm 10\%$, $\emptyset = 0.5$ to 10 MHz, $V_{SS} = 0$ V, $T_a = -20$ to 75°C (regular specifications), $T_a = -40$ to 85°C (wide-range specifications)

Item	Symbol	Measurement conditions	6MHz		8MHz		10MHz		Unit	
			min	max	min	max	min	max		
TMR	Timer output delay time	tTMOD	Fig. 15-13	–	100	–	100	–	100	ns
	Timer reset input setup time	tTMRS	Fig. 15-15	50	–	50	–	50	–	ns
	Timer clock input setup time	tTMCS	Fig. 15-14	50	–	50	–	50	–	ns
	Timer clock pulse width (single edge)	tTMCWH tTMCWL	Fig. 15-14	1.5	–	1.5	–	1.5	–	t _{eyc}
	Timer clock pulse width (both edges)		Fig. 15-14	2.5	–	2.5	–	2.5	–	t _{eyc}
SCI	Input clock (Async)	tS _{yc}	Fig. 15-16	2	–	2	–	2	–	t _{eyc}
	Input clock (Sync)	tS _{yc}	Fig. 15-16	4	–	4	–	4	–	t _{eyc}
	Transmit data delay time (Sync)	tTXD	Fig. 15-16	–	100	–	100	–	100	ns
	Receive data setup time (Sync)	tRXS	Fig. 15-16	100	–	100	–	100	–	ns
	Receive data hold time (Sync)	tRXH	Fig. 15-16	100	–	100	–	100	–	ns
	Input clock pulse width	tSCKW	Fig. 15-17	0.4	0.6	0.4	0.6	0.4	0.6	t _{S_{yc}}
Ports	Output data delay time	tPWD	Fig. 15-18	–	100	–	100	–	100	ns
	Input data setup time	tPRS	Fig. 15-18	50	–	50	–	50	–	ns
	Input data hold time	tPRH	Fig. 15-18	50	–	50	–	50	–	ns

Table 15-6. Timing Conditions of On-Chip Supporting Modules (cont.)

Conditions: $V_{CC} = 5.0V \pm 10\%$, $\phi = 0.5$ to 10 MHz, $V_{SS} = 0$ V,

$T_a = -20$ to 75°C (regular specifications), $T_a = -40$ to 85°C (wide-range specifications)

Item	Symbol	Measurement conditions	6MHz		8MHz		10MHz		Unit	
			min	max	min	max	min	max		
Parallel handshake interface	Handshake input strobe pulse width	t_{HSW}	Fig. 15-19	1.5	–	1.5	–	1.5	–	tcyc
	Handshake input data setup time	t_{HS}	Fig. 15-19	10	–	10	–	10	–	ns
	Handshake input data hold time	t_{HH}	Fig. 15-19	120	–	120	–	120	–	ns
	Handshake output strobe delay time	t_{HOSD1}	Fig. 15-20	–	80	–	80	–	80	ns
		t_{HOSD2}	Fig. 15-20	–	80	–	80	–	80	ns
	Busy output delay time	t_{HSOD1}	Fig. 15-21	–	150	–	150	–	150	ns
		t_{HSOD2}	Fig. 15-21	–	150	–	150	–	150	ns

• Measurement Conditions for AC Characteristics

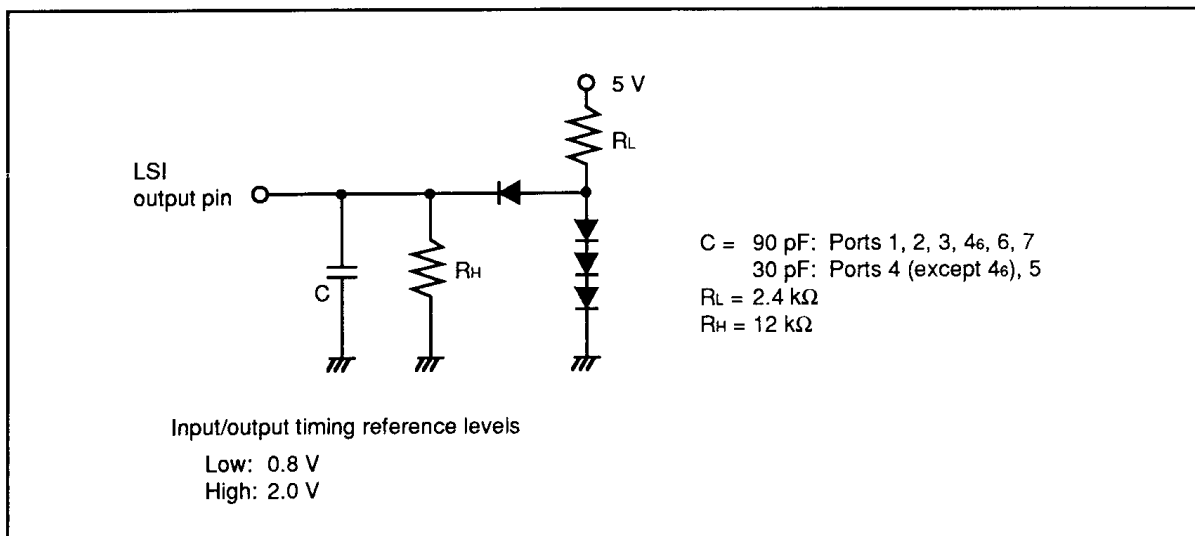

Figure 15-3. Output Load Circuit

15.3 MCU Operational Timing

This section provides the following timing charts:

15.3.1 Bus Timing	Figures 15-4 to 15-6
15.3.2 Control Signal Timing	Figures 15-7 to 15-10
15.3.3 16-Bit Free-Running Timer Timing	Figures 15-11 to 15-12
15.3.4 8-Bit Timer Timing	Figures 15-13 to 15-15
15.3.6 SCI Timing	Figures 15-15 to 15-17
15.3.7 I/O Port Timing	Figure 15-18
15.3.8 Parallel Handshaking Interface Timing	Figures 15-19 to 15-21

15.3.1 Bus Timing

(1) Basic Bus Cycle (without Wait States) in Expanded Modes

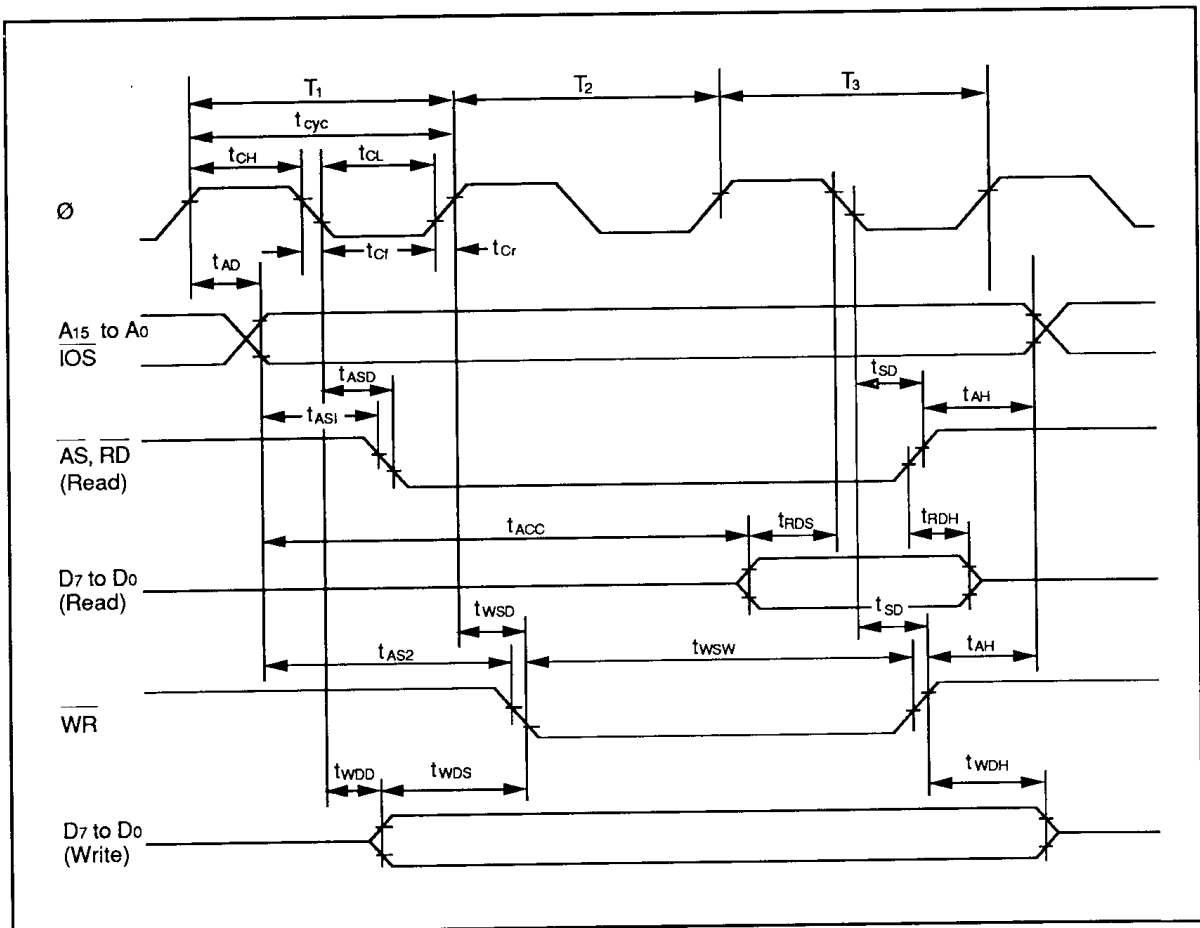

Figure 15-4. Basic Bus Cycle (without Wait States) in Expanded Modes

(2) Basic Bus Cycle (with 1 Wait State) in Expanded Modes

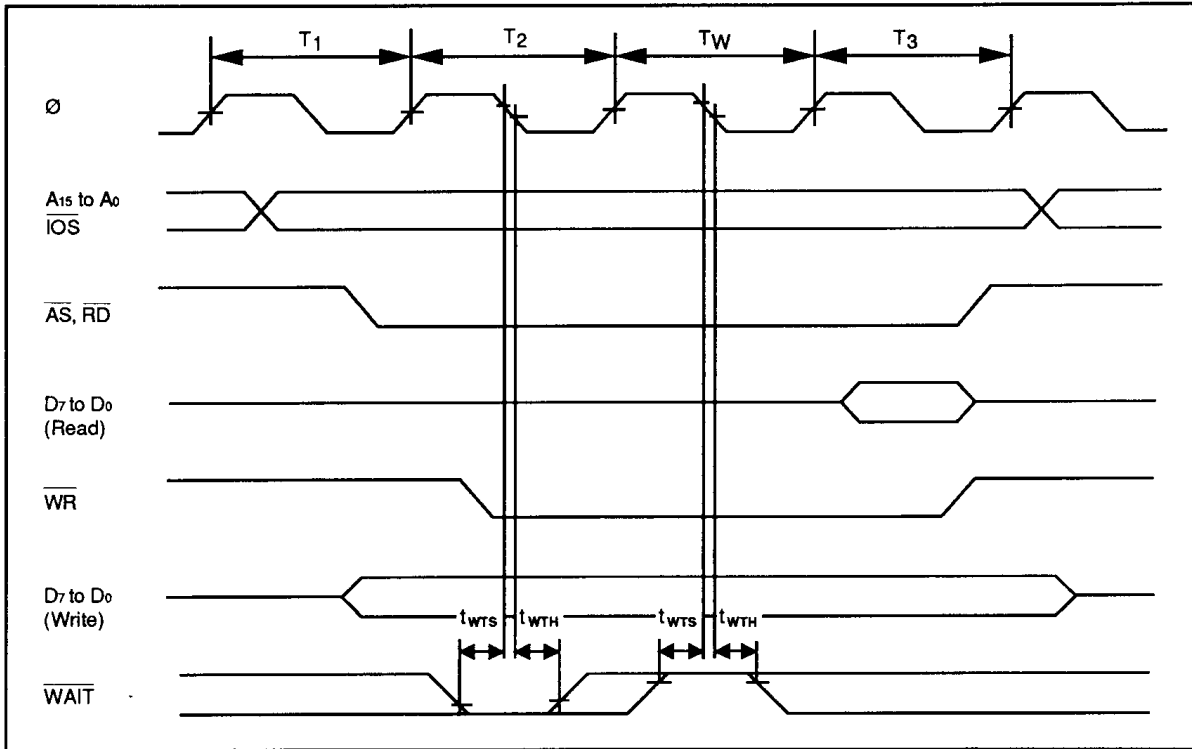

Figure 15-5. Basic Bus Cycle (with 1 Wait State) in Expanded Modes

(3) E Clock Bus Cycle

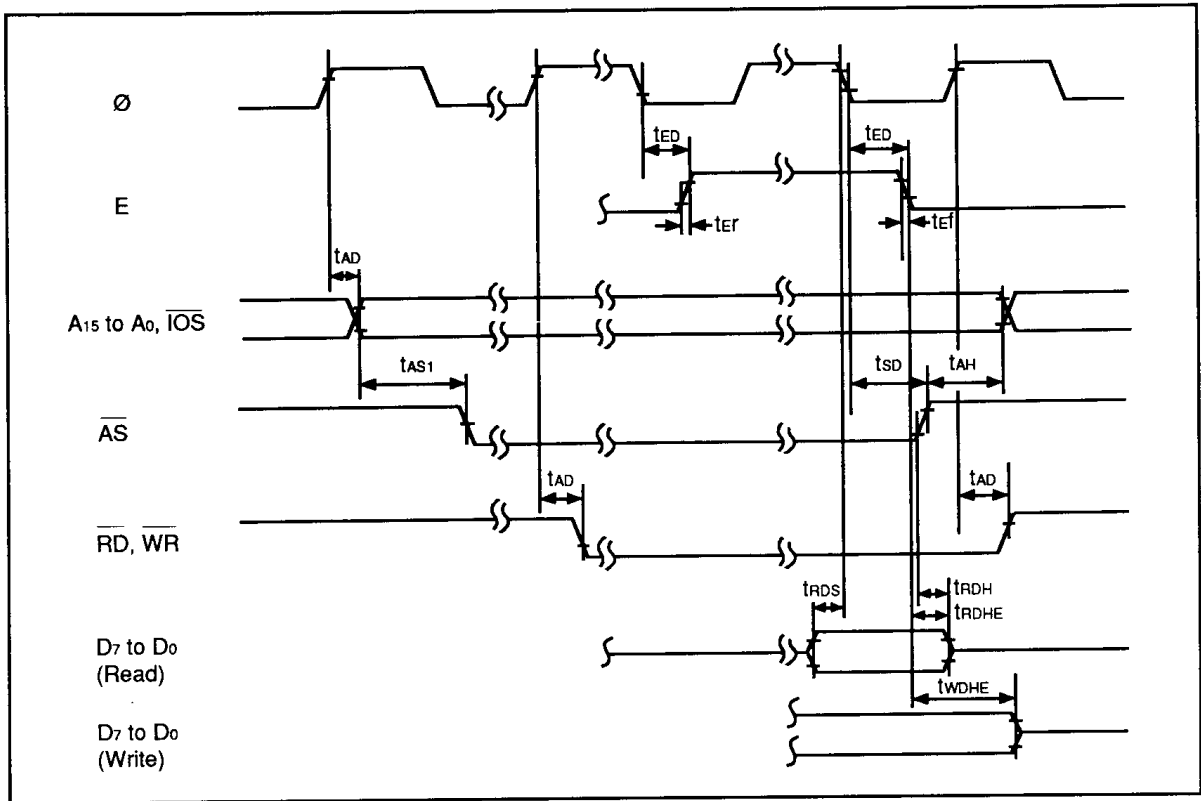

Figure 15-6. E Clock Bus Cycle

15.3.2 Control Signal Timing

(1) Reset Input Timing

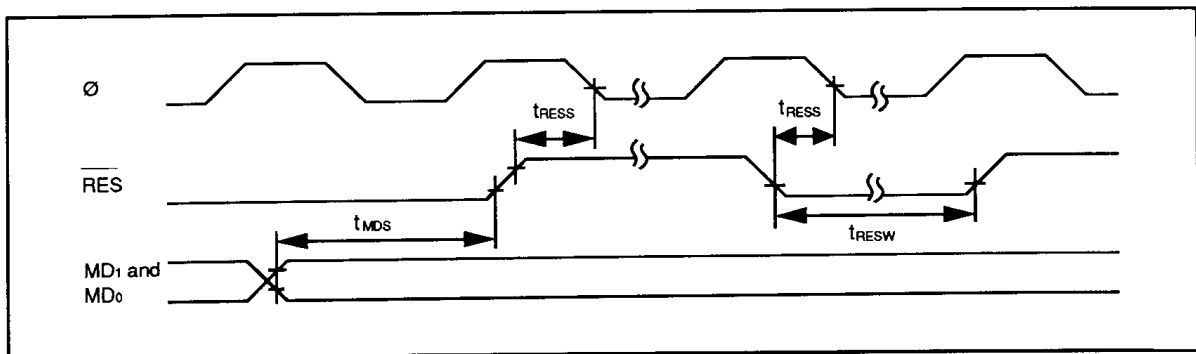

Figure 15-7. Reset Input Timing

(2) Interrupt Input Timing

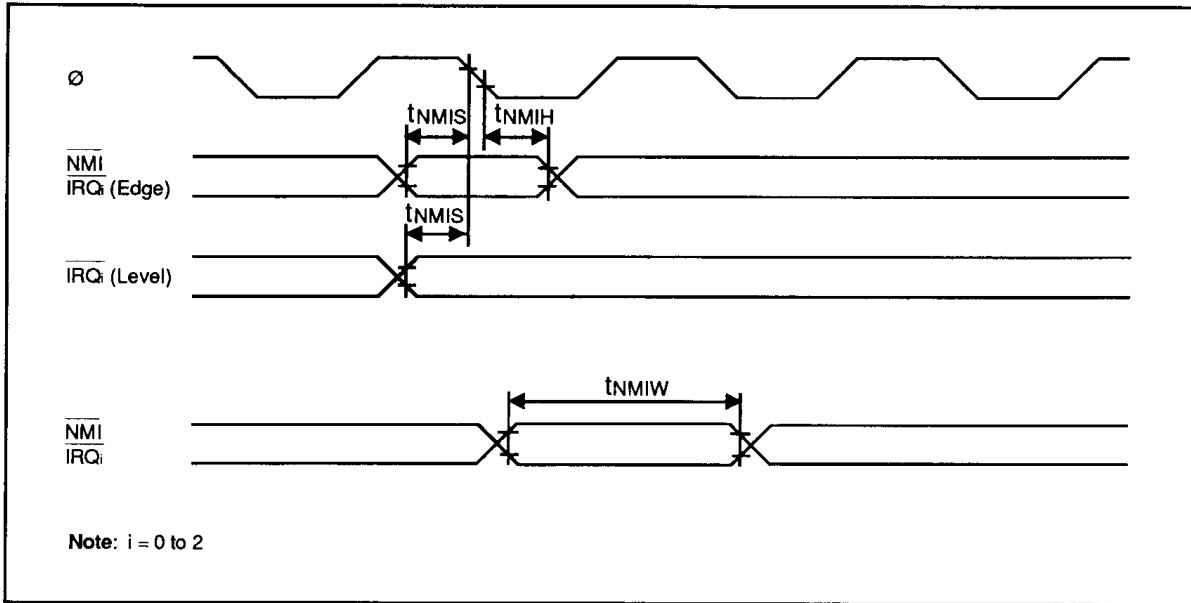

Figure 15-8. Interrupt Input Timing

(3) Clock Settling Timing

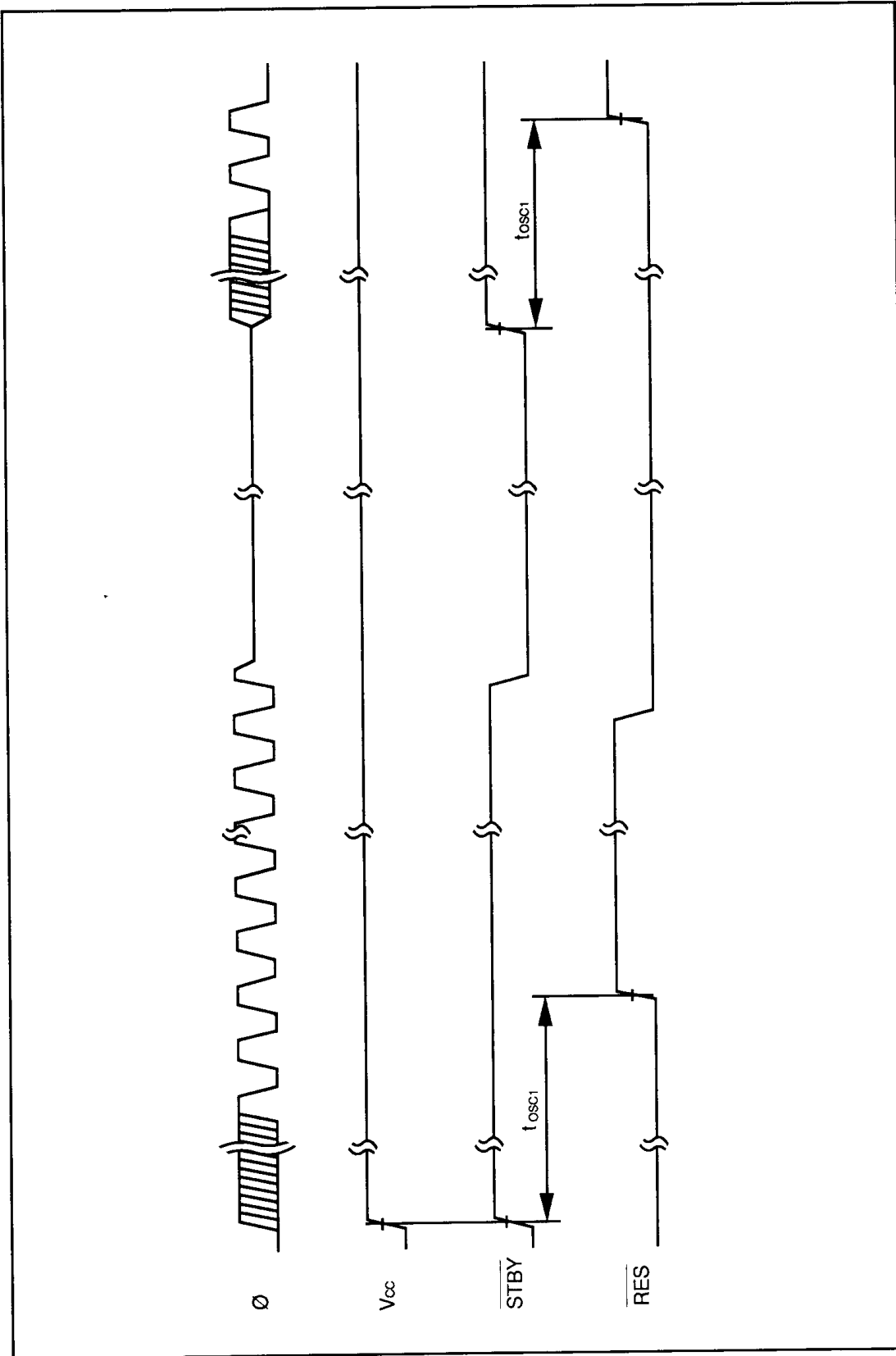

Figure 15-9. Clock Settling Timing

(4) Clock Settling Timing for Recovery from Software Standby Mode

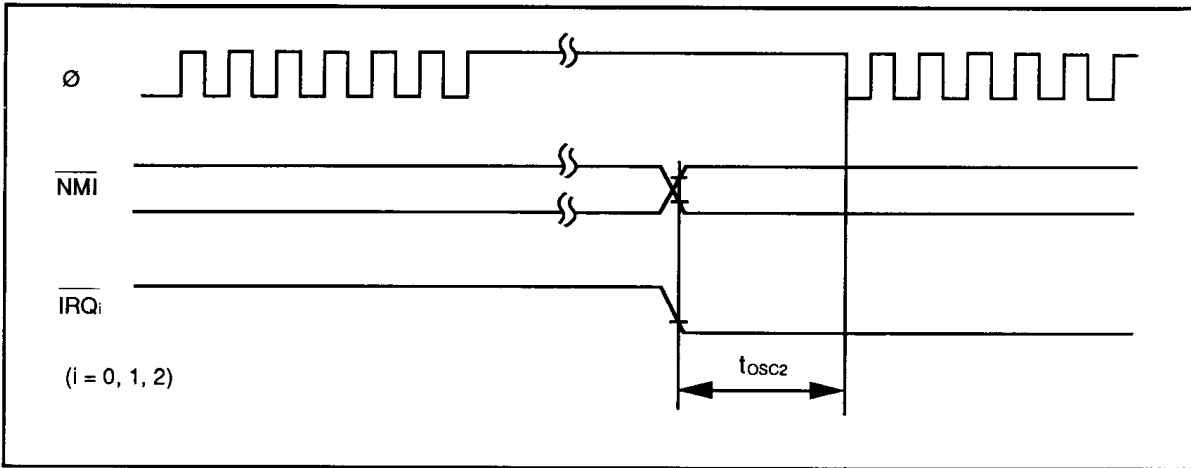

Figure 15-10. Clock Settling Timing for Recovery from Software Standby Mode

15.3.3 16-Bit Free-Running Timer Timing

(1) Free-Running Timer Input/Output Timing

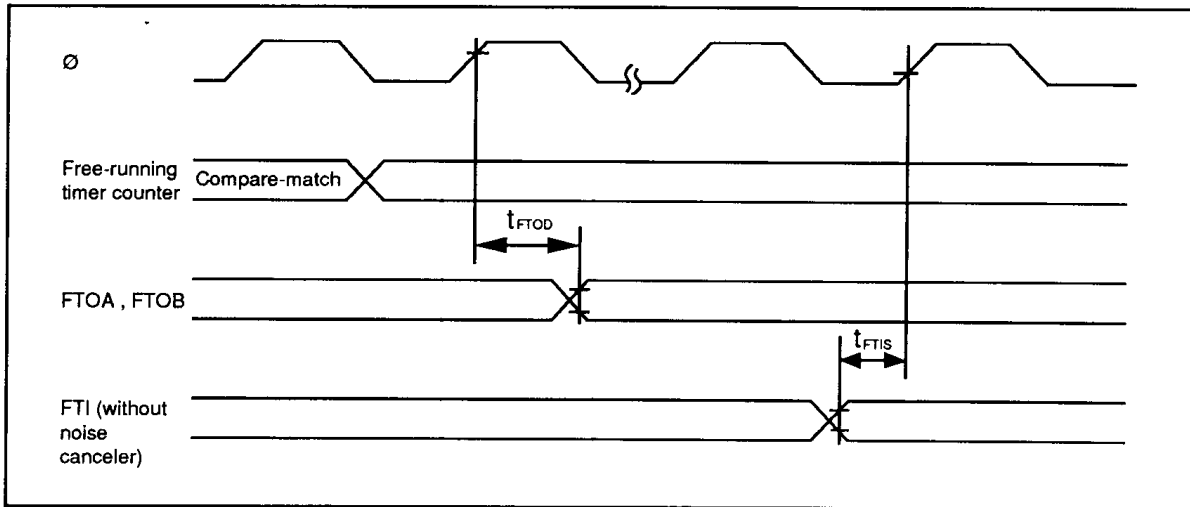

Figure 15-11. Free-Running Timer Input/Output Timing

(2) External Clock Input Timing for Free-Running Timer

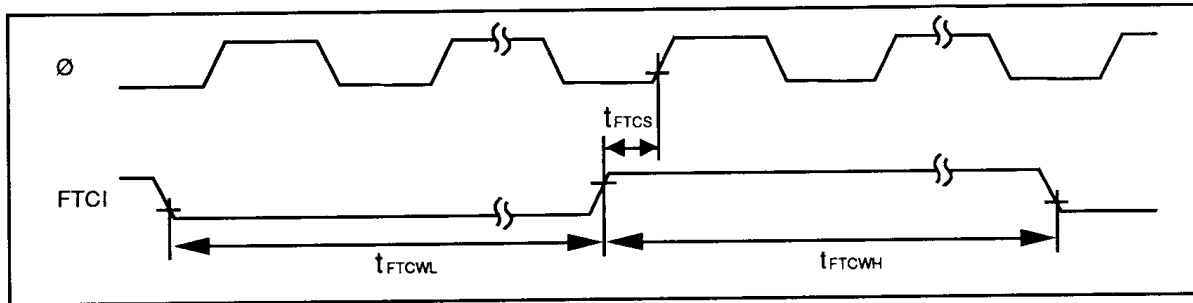

Figure 15-12. External Clock Input Timing for Free-Running Timer

15.3.4 8-Bit Timer Timing

(1) 8-Bit Timer Output Timing

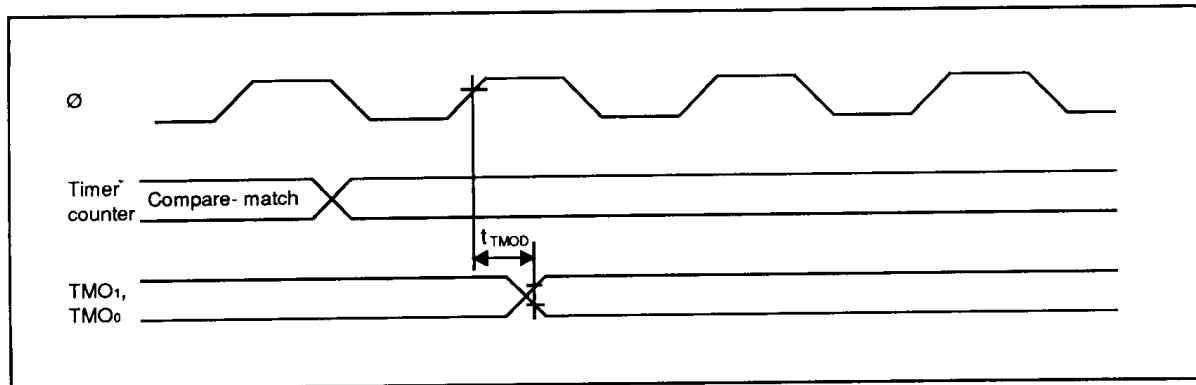

Figure 15-13. 8-Bit Timer Output Timing

(2) 8-Bit Timer Clock Input Timing

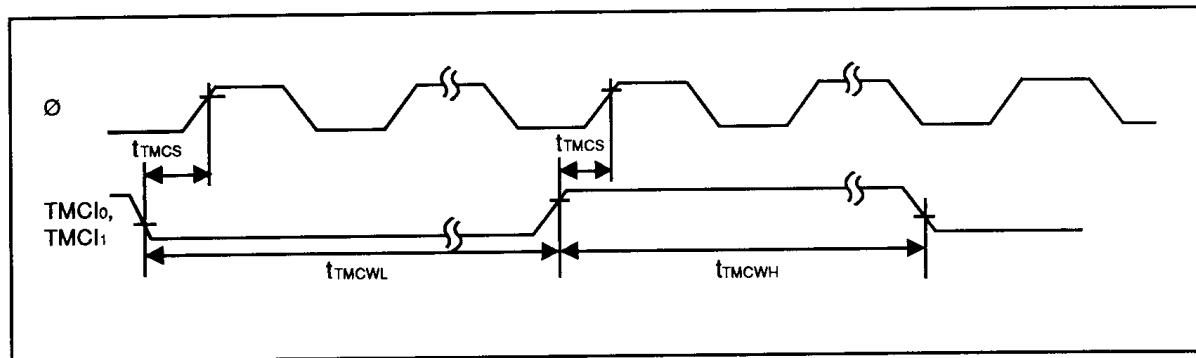

Figure 15-14. 8-Bit Timer Clock Input Timing

(3) 8-Bit Timer Reset Input Timing

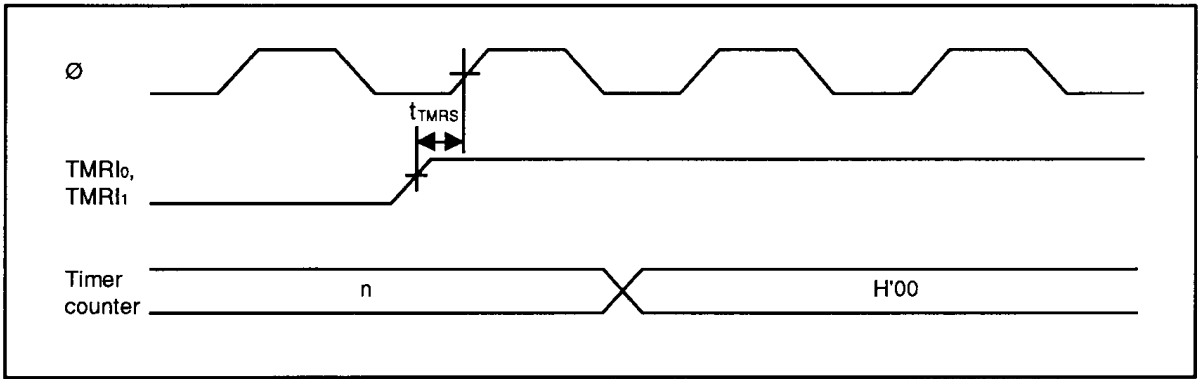

Figure 15-15. 8-Bit Timer Reset Input Timing

15.3.5 Serial Communication Interface Timing

(1) SCI Input/Output Timing

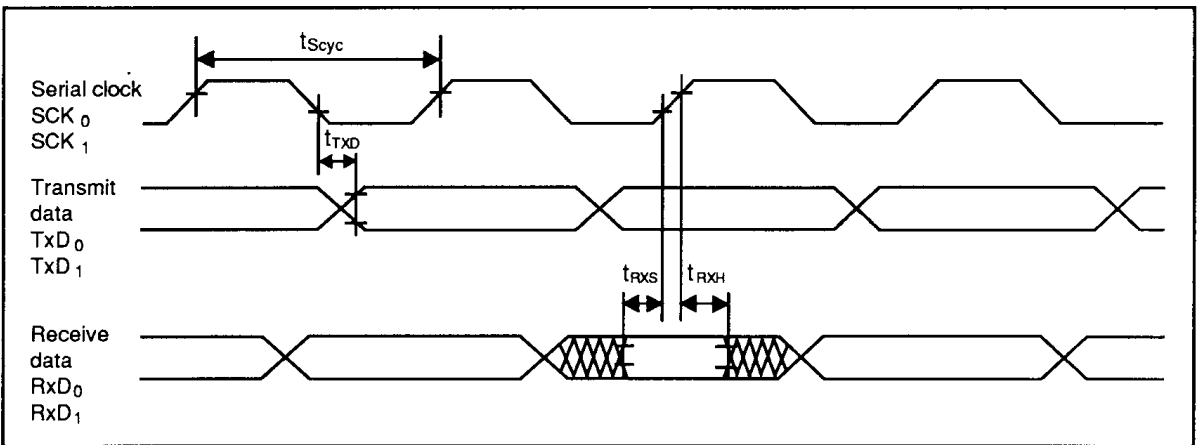

Figure 15-16. SCI Input/Output Timing (Synchronous Mode)

(2) SCI Input Clock Timing

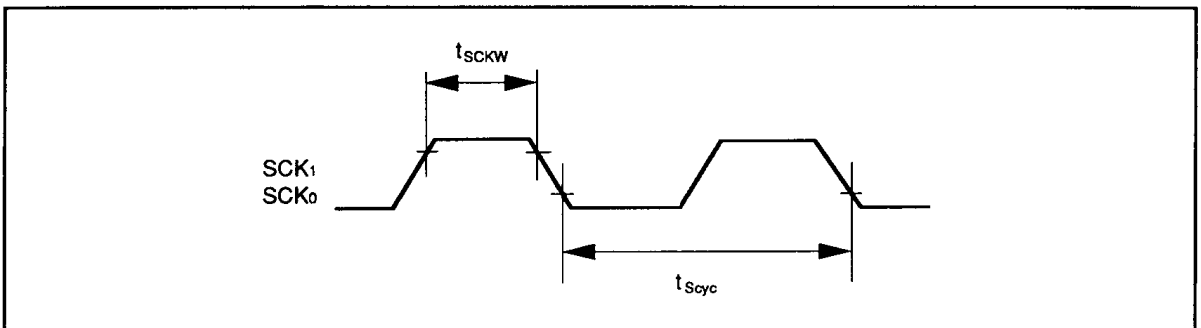

Figure 15-17. SCI Input Clock Timing

15.3.6 I/O Port Timing

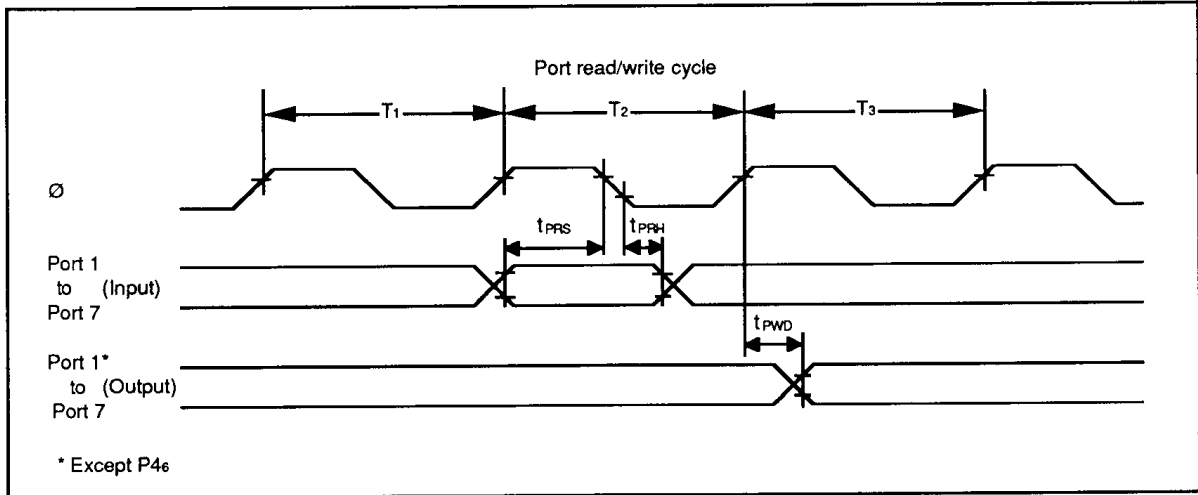

Figure 15-18. I/O Port Input/Output Timing

15.3.7 Parallel Handshake Interface Timing

(1) Input Strobe Input Timing

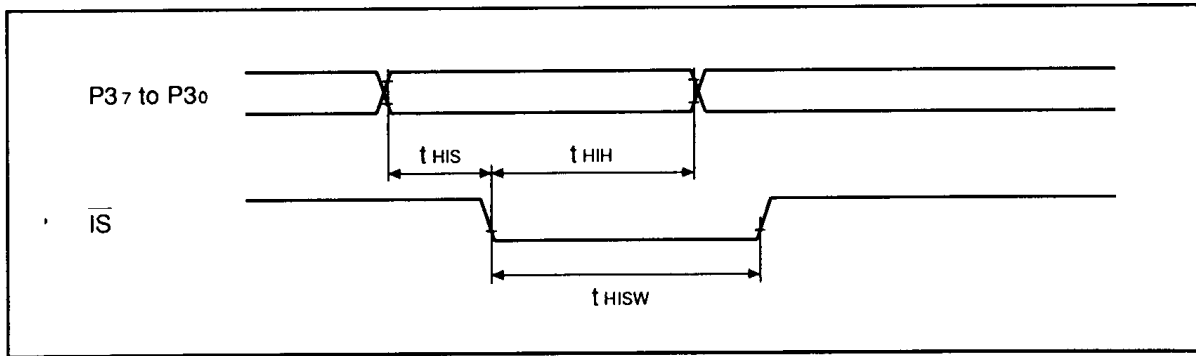

Figure 15-19. Input Strobe Input Timing

(2) Output Strobe Output Timing

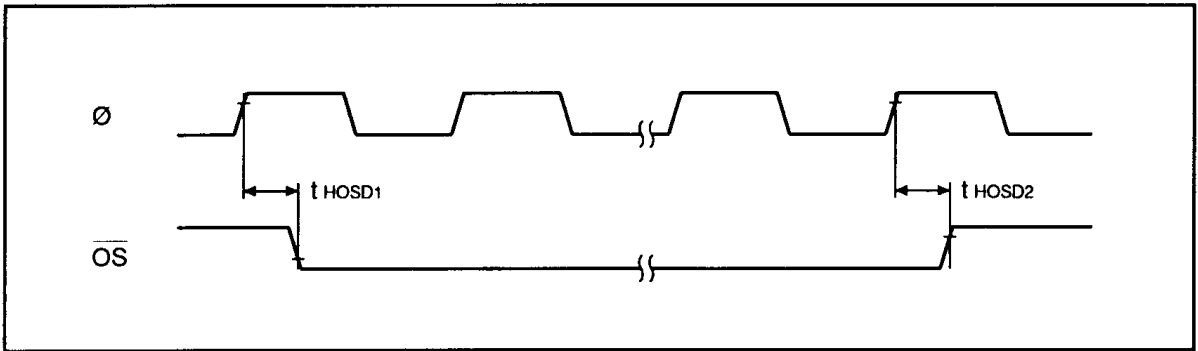

Figure 15-20. Output Strobe Output Timing

(3) Busy Output Timing

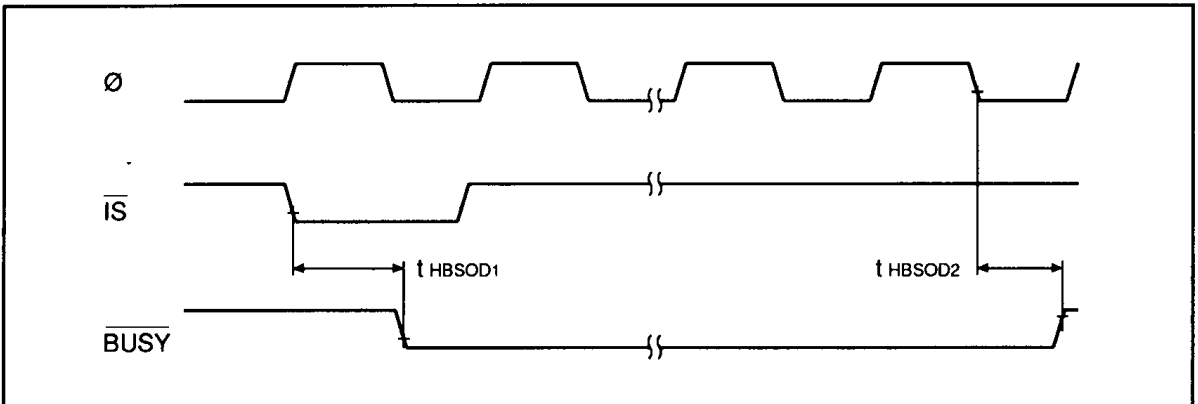

Figure 15-21. Busy Output Timing

Table C-1. Pin States (cont.)

T-90-01

Pin Name	MCU Mode	Reset	Hardware Standby	Software Standby	Sleep Mode	Normal Operation
P55 to P50,	1	3-State	3-State	Prev. state (note 3)	Prev. state	I/O port
	2					
	3					
P66 to P60,	1	3-State	3-State	Prev. state (note 3)	Prev. state	I/O port
	2					
	3					
P77/ $\overline{\text{WAIT}}$	1	3-State	3-State	3-state	3-state	$\overline{\text{WAIT}}$
	2					
	3					
P76 to P74, $\overline{\text{AS}}$, $\overline{\text{WR}}$, $\overline{\text{RD}}$,	1	High	3-State	High	High	$\overline{\text{AS}}$, $\overline{\text{WR}}$, $\overline{\text{RD}}$
	2					
	3					
P73 to P70,	1	3-State	3-State	Prev. state	Prev. state	I/O port
	2					
	3					

Notes:

1. 3-state: High-impedance state
2. Prev. state: Previous state. Input ports are in the high-impedance state (with the MOS pull-up on if DDR = 0 and DR = 1). Output ports hold their previous output level.
3. On-chip supporting modules are initialized, so these pins revert to I/O ports according to the DDR and DR bits.
4. I/O port: Direction depends on the data direction (DDR) bit. Note that these pins may also be used by the on-chip supporting modules.

See section 5, I/O Ports for further information.

Appendix D. Package Dimensions

T-90-20

Figure D-1 shows the dimensions of the DC-64S package. Figure D-2 shows the dimensions of the DP-64S package. Figure D-3 shows the dimensions of the FP-64A package.

Unit: mm (inch)

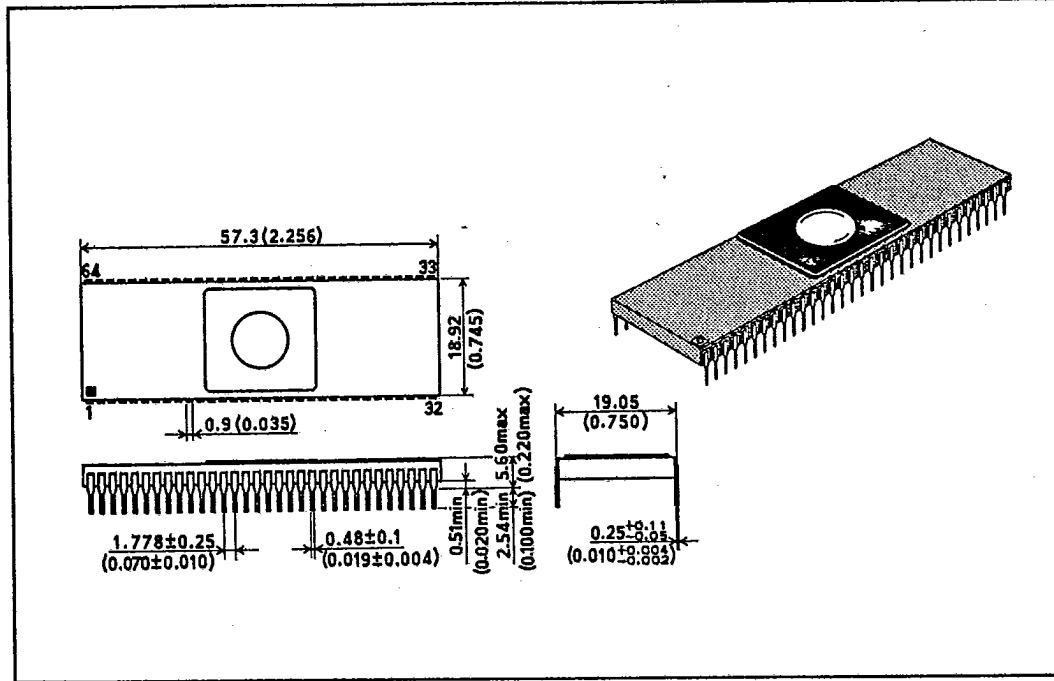

D

Figure D-1. Package Dimensions (DC-64S)

Unit: mm (inch)

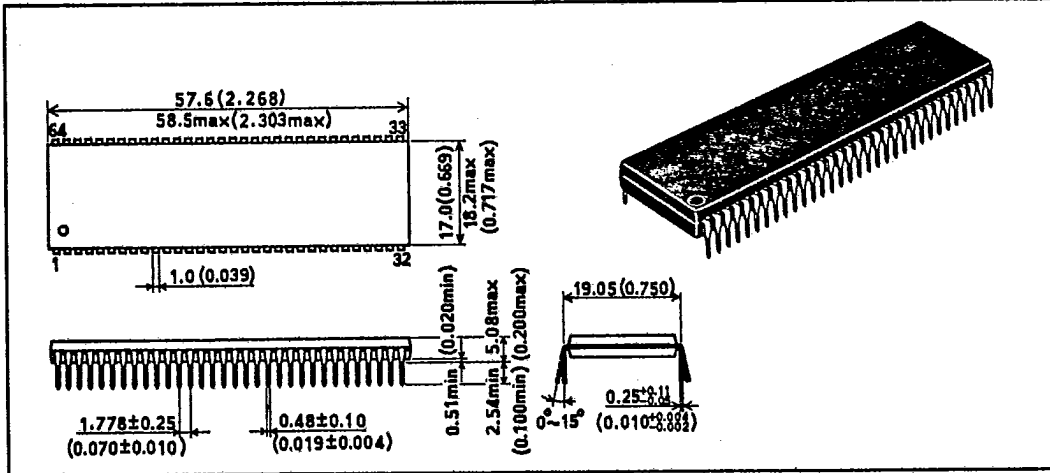

Figure D-2. Package Dimensions (DP-64S)

Appendix E. Package Dimensions

T-90-20

Figure D-1 shows the dimensions of the DC-64S package. Figure D-2 shows the dimensions of the DP-64S package. Figure D-3 shows the dimensions of the FP-64A package. Figure D-4 shows the dimensions of the CP-68 package.

Unit: mm

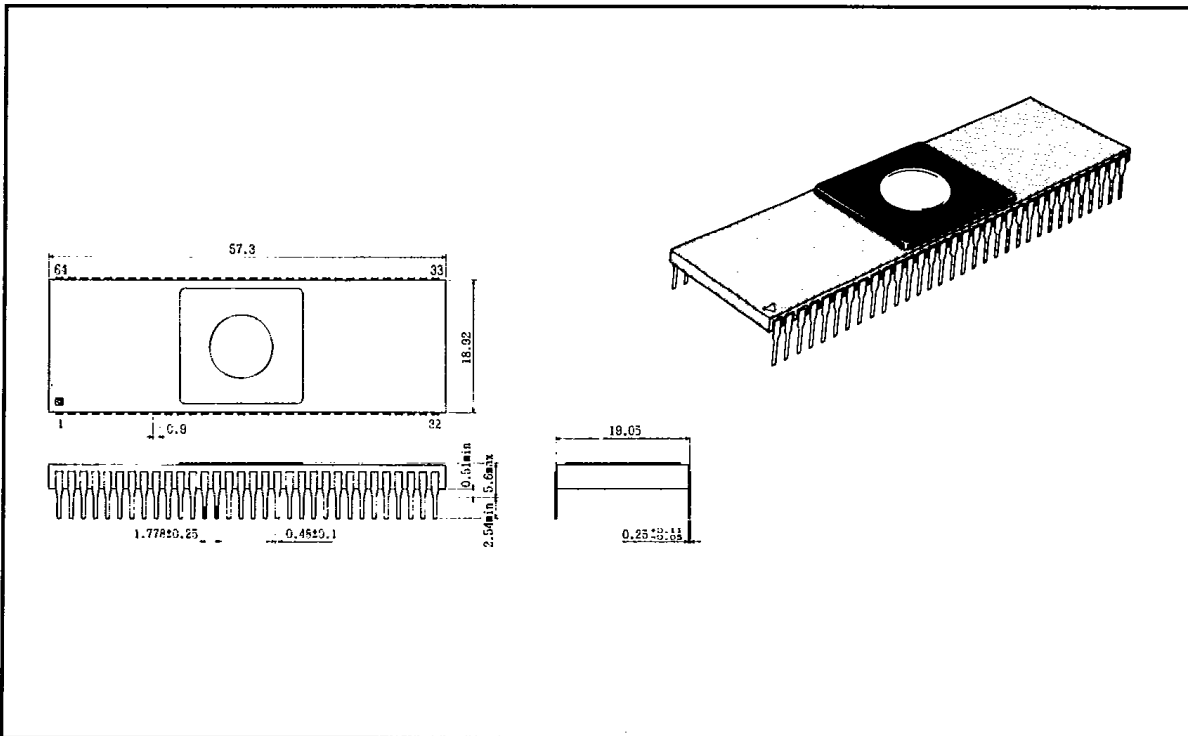

Figure E-1. Package Dimensions (DC-64S)

Unit: mm

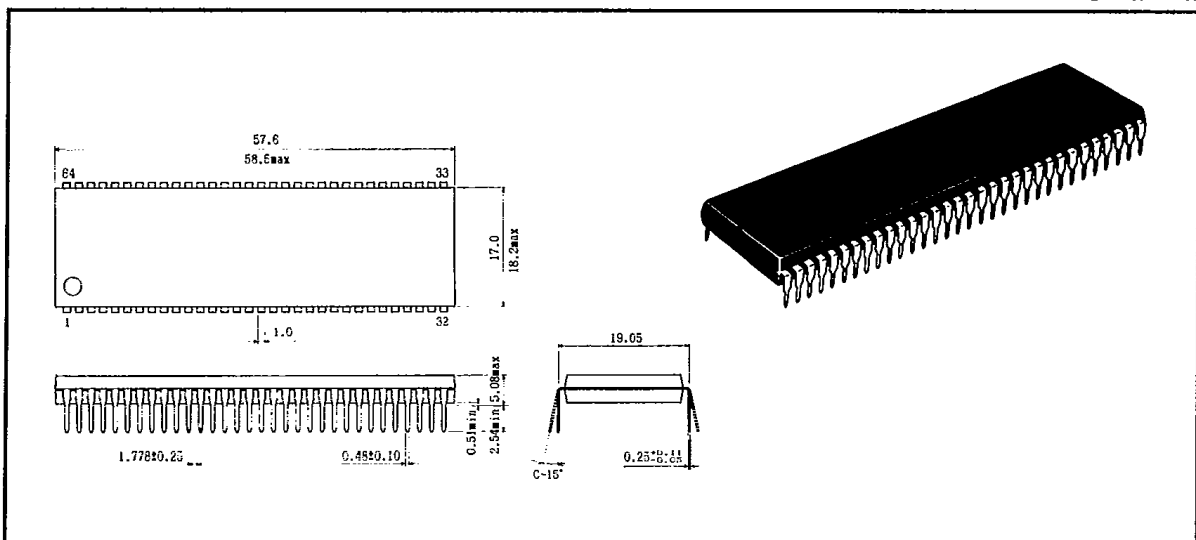

Figure E-2. Package Dimensions (DP-64S)

Unit: mm

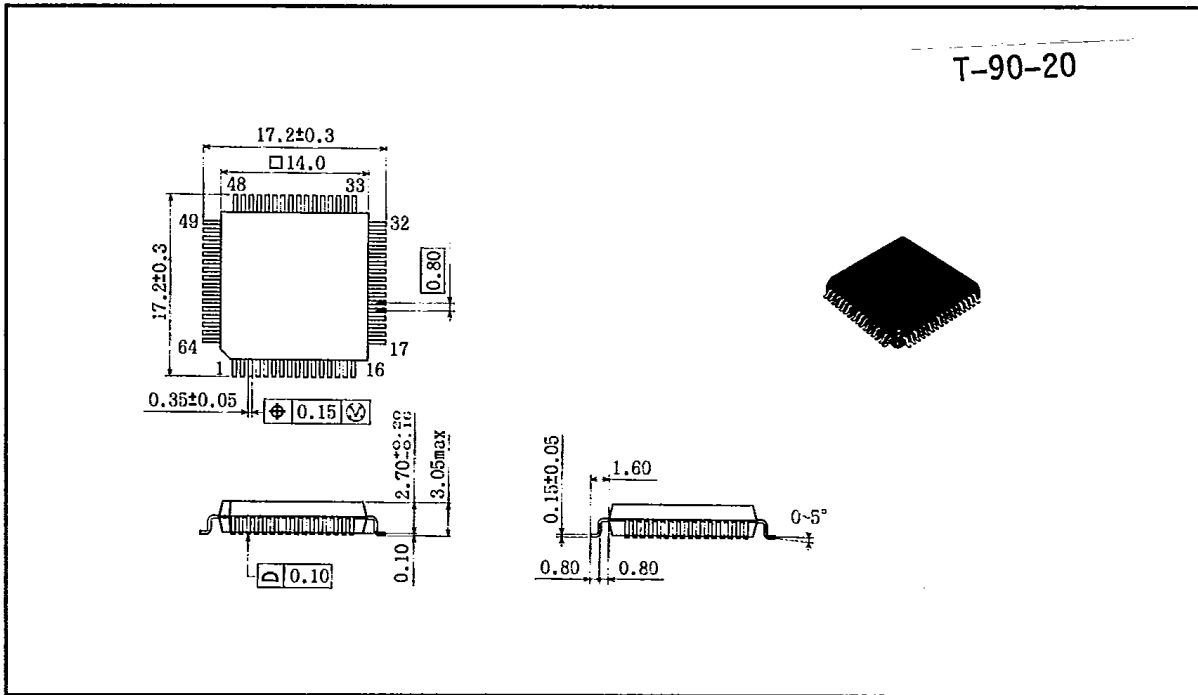

Figure E-3. Package Dimensions (FP-64A)

Unit: mm

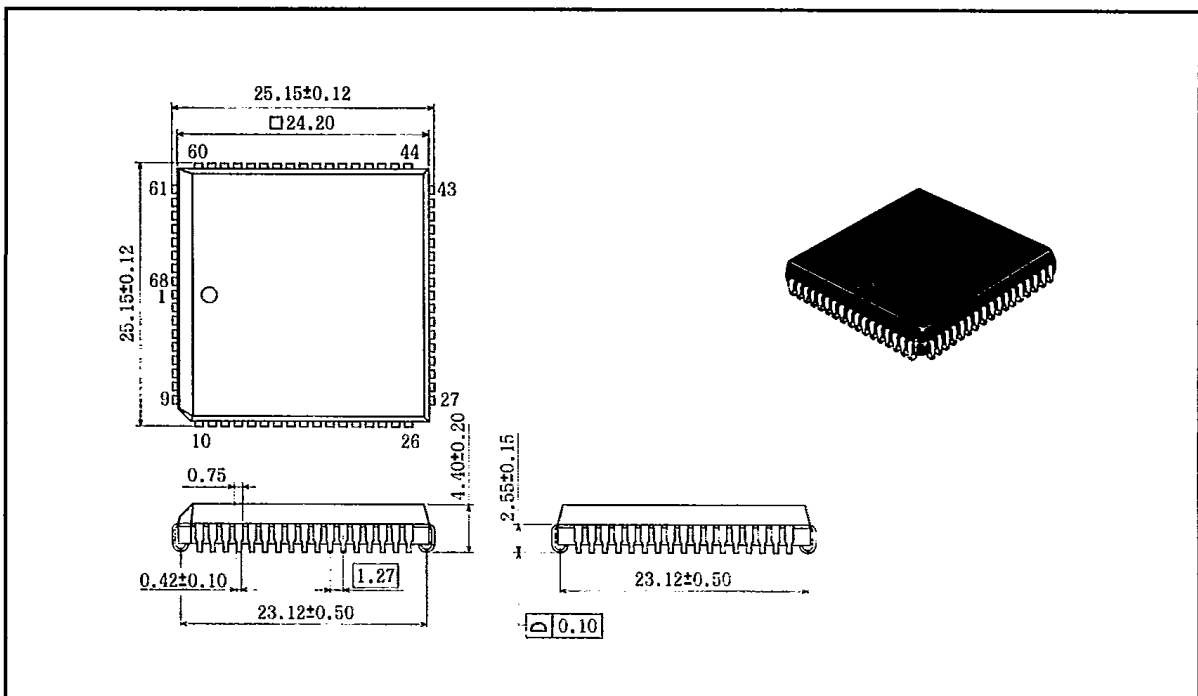

Figure E-4. Package Dimensions (CP-68)