

HSM125WK

Silicon Schottky Barrier Diode for Battery Switch

HITACHI

Preliminary
Rev.0
Oct. 1993

Features

- The HSM125WK has two different (V_F - I_F) chips, and can change the main battery to the backup battery automatically.
- MPAK package is suitable for high density surface mounting and high speed assembly.

Ordering Information

Type No.	Laser Mark	Package Code
HSM125WK	S13	MPAK

Pin Arrangement

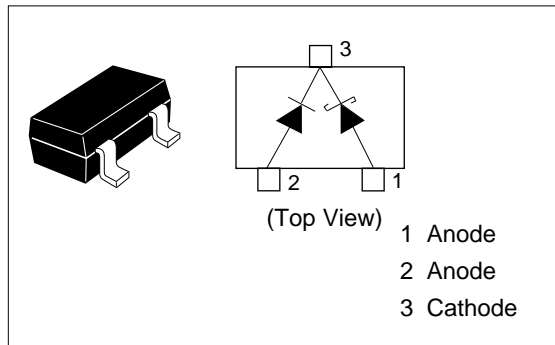

Absolute Maximum Ratings ($T_a = 25^\circ\text{C}$)

Item	Symbol	Value Pin 1-3	Value Pin 2-3	Unit
Peak reverse voltage	V_{RM}	20	20	V
Forward current	I_F^*	500	100	mA
Junction temperature	T_j	125	125	$^\circ\text{C}$
Storage temperature	T_{stg}	-55 to +125	-55 to +125	$^\circ\text{C}$

* Per one device

Electrical Characteristics ($T_a = 25^\circ\text{C}$)

Item	Symbol	Min	Typ	Max	Unit	Test Condition	
Forward voltage	V_{F1}	Pin 1-3	0.1	—	0.3	V	$I_F = 1 \text{ mA}$
		Pin 2-3	0.5	—	0.8		
Forward voltage	V_{F2}	Pin 1-3	—	—	0.55	V	$I_F = 500 \text{ mA}$
		Pin 2-3	—	—	1.2		$I_F = 100 \text{ mA}$
Reverse current	I_R	Pin 1-3	—	—	30	μA	$V_R = 20 \text{ V}$
		Pin 2-3	—	—	0.1		
ESD Capability	—	200	—	—	V	* C=200pF, Both forward and reverse direction 1 pulse	

* Failure Criterion ; Pin 1-3 ($I_R \geq 60\mu\text{A}$ at $V_R = 20\text{V}$) , Pin 2-3 ($I_R \geq 0.2\mu\text{A}$ at $V_R = 20\text{V}$)

HSM125WK

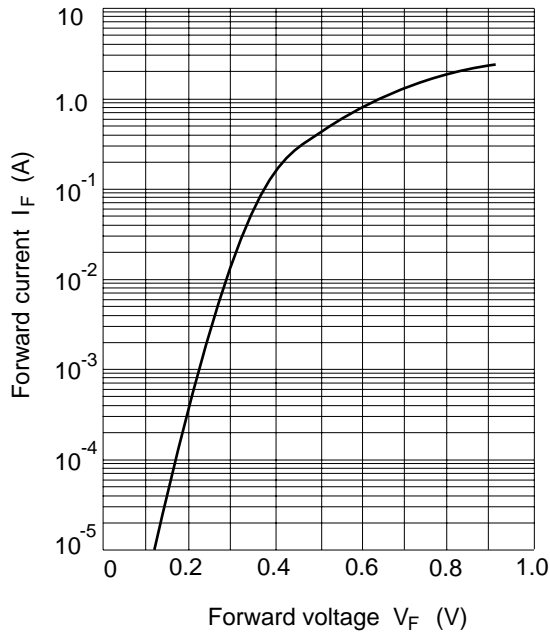

Fig.1 Forward current Vs. Forward voltage (Pin1-3)

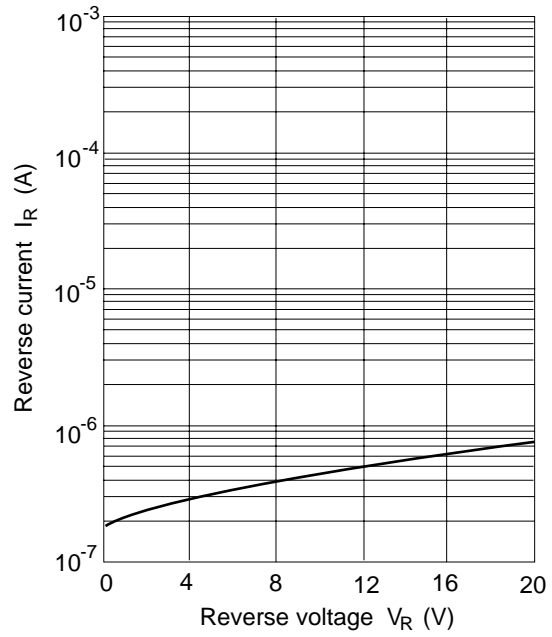

Fig.2 Reverse current Vs. Reverse voltage (Pin1-3)

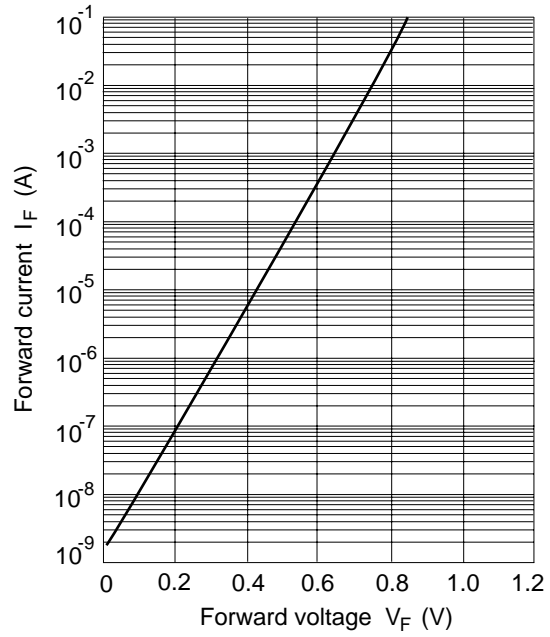

Fig.3 Forward current Vs. Forward voltage (Pin2-3)

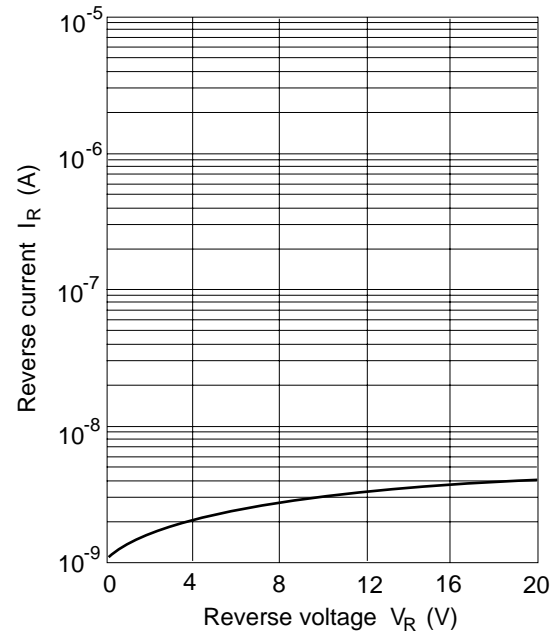

Fig.4 Reverse current Vs. Reverse voltage (Pin2-3)

Package Dimensions

Unit: mm

