

### Features

- Operating voltage: 2.4V~12V
- Low power and high noise immunity CMOS technology
- Low standby current
- Capable of decoding 12 bits of information
- 8~12 address pins
- 0~4 data pins
- Trinary address setting
- Received data are checked two times
- Built-in oscillator needs only 5% resistor
- VT goes high during a valid transmission
- Easy interface with an RF or an infrared transmission medium
- Minimal external components
- Pair with Holtek's 3<sup>12</sup> series of encoders
- 18-pin DIP, 20-pin SOP package

### Applications

- Burglar alarm system
- Smoke and fire alarm system
- Garage door controllers
- Car door controllers
- Car alarm system
- Security system
- Cordless telephones
- Other remote control systems

### General Description

The 3<sup>12</sup> decoders are a series of CMOS LSIs for remote control system applications. They are paired with 3<sup>12</sup> series of encoders. For proper operation a pair of encoder/decoder with the same number of address and data format should be selected (refer to the encoder/decoder cross reference tables).

The 3<sup>12</sup> series of decoders receive serial address and data from its corresponding series of encoders that are transmitted by a carrier using an RF or an IR transmission medium. Then it compares the serial input information twice continuously with its local address. If no errors

or unmatched codes are encountered, the input data codes are decoded and transferred to the output pins. The VT pin also goes high to indicate a valid transmission.

The 3<sup>12</sup> series of decoders are capable of decoding 12 bits of information that consists of N bits of address and 12-N bits of data. To meet various applications they are arranged to provide a number of data pins ranging from 0 to 4 and an address pin ranging from 8 to 12. Thus, various combinations of address/data number are available in different packages.

### Selection Table

Part No.	Function	Address No.	Data		VT	Oscillator	Trigger	Package
			No.	Type				
HT6030		12	0	—	√	RC oscillator	DIN active "Hi"	18DIP, 20SOP
HT6032		10	2	L	√	RC oscillator	DIN active "Hi"	18DIP, 20SOP
HT6034		8	4	L	√	RC oscillator	DIN active "Hi"	18DIP, 20SOP

Note: Data type: L stands for latch type data output.

VT can be used as a momentary data output.

**Block Diagram**

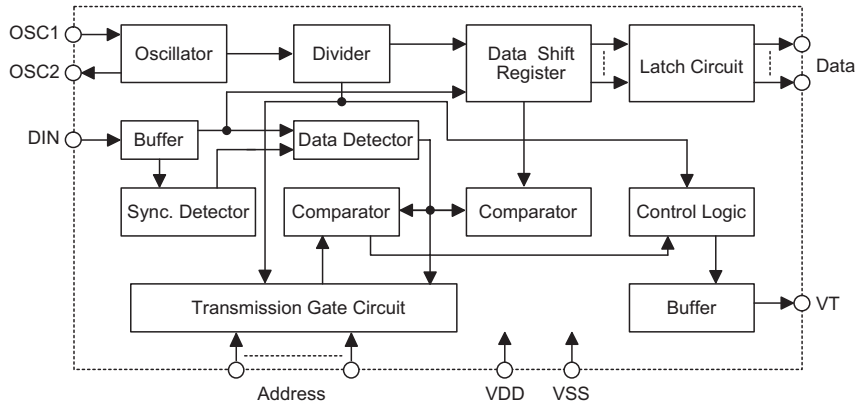

Note: The address/data pins are available in various combinations (refer to the address/data table).

**Pin Assignment**

**12-Address  
0-Data**

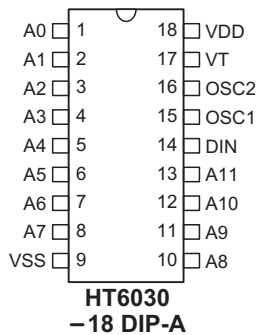

**12-Address  
0-Data**

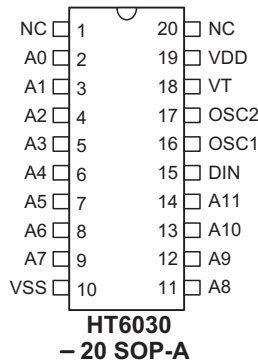

**10-Address  
2-Data**

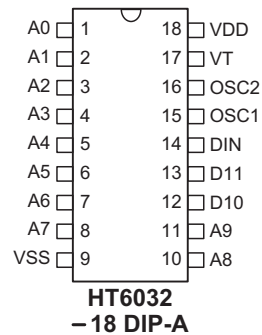

**10-Address  
2-Data**

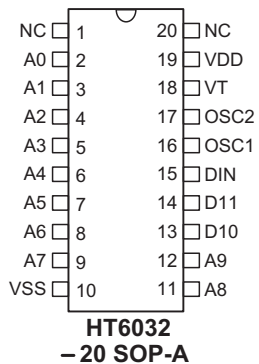

**8-Address  
4-Data**

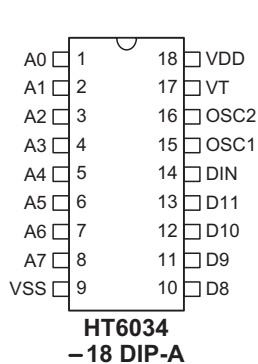

**8-Address  
4-Data**

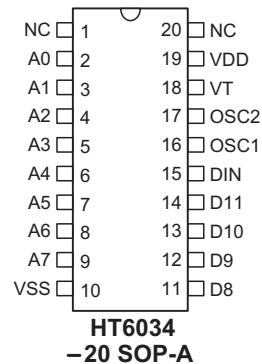

**Pin Description**

Pin Name	I/O	Internal Connection	Description
A0~A11	I	TRANSMISSION GATE	Input pins for address A0~A11 setting They can be externally set to VDD, VSS, or left open.
D8~D11	O	CMOS OUT	Output data pins
DIN	I	CMOS IN	Serial data input pin
VT	O	CMOS OUT	Valid transmission, active high
OSC1	I	OSCILLATOR	Oscillator input pin
OSC2	O	OSCILLATOR	Oscillator output pin
VSS	—	—	Negative power supply, ground
VDD	—	—	Positive power supply

**Approximate Internal Connections**

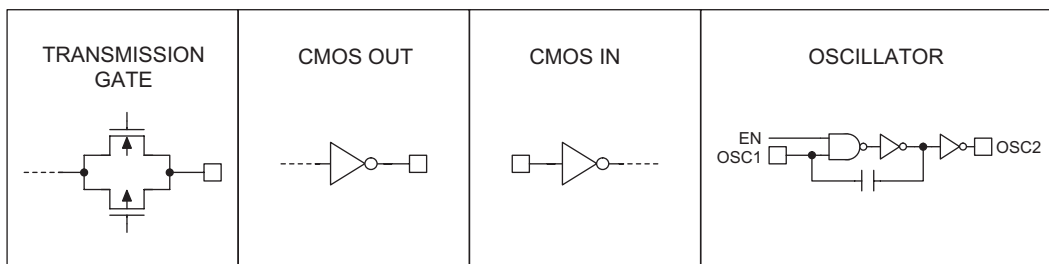

**Absolute Maximum Ratings**

Supply Voltage ..... $V_{SS}-0.3V$  to  $V_{SS}+13V$       Storage Temperature ..... $-50^{\circ}C$  to  $125^{\circ}C$   
 Input Voltage ..... $V_{SS}-0.3$  to  $V_{DD}+0.3V$       Operating Temperature..... $-20^{\circ}C$  to  $75^{\circ}C$

Note: These are stress ratings only. Stresses exceeding the range specified under "Absolute Maximum Ratings" may cause substantial damage to the device. Functional operation of this device at other conditions beyond those listed in the specification is not implied and prolonged exposure to extreme conditions may affect device reliability.

**Electrical Characteristics**

Ta=25°C

Symbol	Parameter	Test Conditions		Min.	Typ.	Max.	Unit
		V <sub>DD</sub>	Conditions				
V <sub>DD</sub>	Operating Voltage	—	—	2.4	5	12	V
I <sub>STB</sub>	Standby Current	5V	Oscillator stops	—	0.1	1	μA
		12V		—	2	4	μA
I <sub>DD</sub>	Operating Current	5V	No load, f <sub>OSC</sub> =100kHz	—	250	500	μA
I <sub>O</sub>	Data Output Source Current (D8~D11)	5V	V <sub>OH</sub> =4.5V	-0.5	-1	—	mA
	Data Output Sink Current (D8~D11)	5V	V <sub>OL</sub> =0.5V	0.5	1	—	mA
I <sub>VT</sub>	VT Output Source Current	5V	V <sub>OH</sub> =4.5V	-2	-4	—	mA
	VT Output Source Current Only For HT6033/35/45			-0.35	-0.6	—	
	VT Output Sink Current		V <sub>OL</sub> =0.5V	1	2	—	
	VT Output Sink Current Only For HT6033/35/45			0.35	0.6	—	
V <sub>IH</sub>	"H" Input Voltage	5V	—	3.5	—	5	V
V <sub>IL</sub>	"L" Input Voltage	5V	—	0	—	1	V
f <sub>OSC</sub>	Oscillator Frequency	5V	R <sub>OSC</sub> =91kΩ	—	100	—	kHz

## Functional Description

### Operation

The 3<sup>12</sup> series of decoders provide various combinations of address and data pins in different packages. They are paired with 3<sup>12</sup> series of encoders. The decoders receive data transmitted by the encoders and interpret the first N bits of the code period as addresses and the last 12-N bits as data (where N is the address code number). A signal on the DIN pin then activates the oscillator which in turn decodes the incoming address and data. The decoders check the received address twice continuously. If all the received address codes match the contents of the decoder's local address, the 12-N bits of data are decoded to activate the output pins and the VT pin is set high indicating a valid transmission. That will last until the address code is incorrect or no signal is received.

The output of the VT pin is high only when the transmission is valid. Otherwise it is always low.

### Output Type

The data outputs follow the encoders during a valid transmission and are then latched in this state until the next valid transmission occurs.

### Flowchart

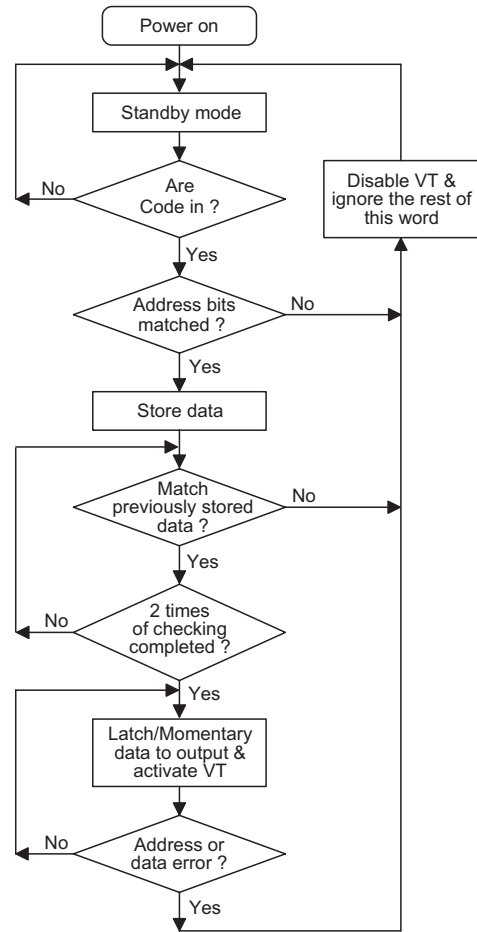

The oscillator is disabled in the standby state and activated as long as a logic "high" signal is applied to the DIN pin. i.e., the DIN pin should be kept "low" if there is no signal input.

### Decoder Timing

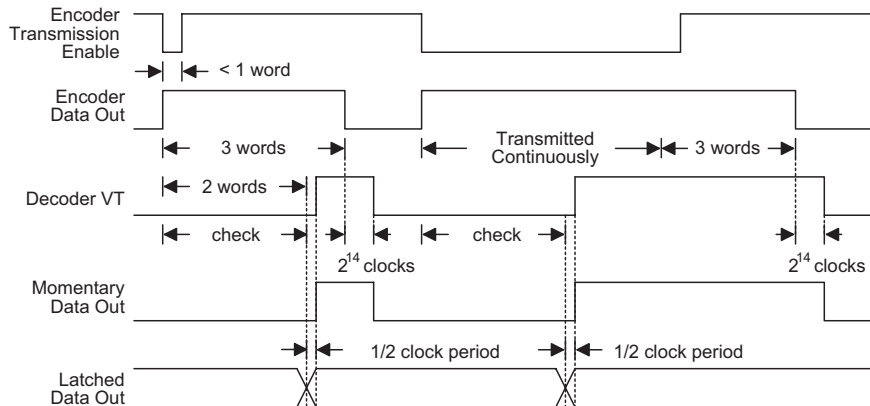

**Encoder/Decoder Cross Reference Tables**

Part No.	Data Pins	Address Pins	VT	Pair Encoder	Package			
					Encoder		Decoder	
					DIP	SOP	DIP	SOP
HT6030	0	12	√	HT6010	18, 20	20	18	20
HT6032	2	10	√	HT6010	18, 20	20	18	20
				HT6012	18	20	18	20
HT6034	4	8	√	HT6010	18, 20	20	18	20
				HT6014	18	20		

**Address/Data Sequence**

The following table describes the position of the address/data sequence for various models of the 3<sup>12</sup> series of decoders.

Part No.	Address/Data Bits											
	0	1	2	3	4	5	6	7	8	9	10	11
HT6030	A0	A1	A2	A3	A4	A5	A6	A7	A8	A9	A10	A11
HT6032	A0	A1	A2	A3	A4	A5	A6	A7	A8	A9	D10	D11
HT6034	A0	A1	A2	A3	A4	A5	A6	A7	D8	D9	D10	D11

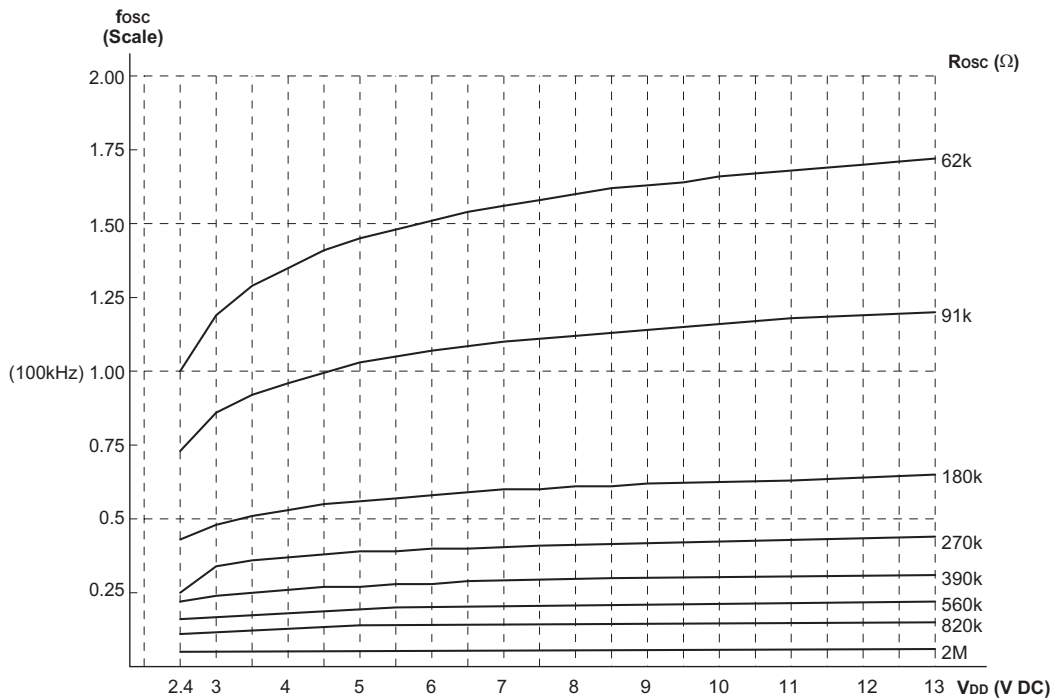
**Oscillator Frequency vs. Supply Voltage**

The Recommended Oscillator Frequency is  $f_{OSCD}$  (Decoder)  $\cong$  33  $f_{OSCE}$  (Encoder)

**Application Circuits**

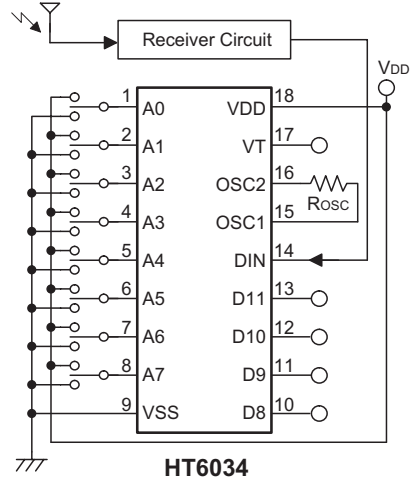
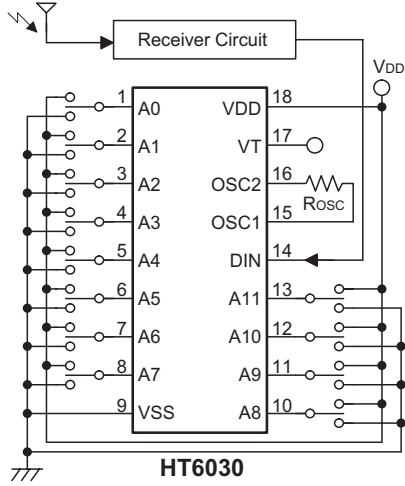

**Package Information**

**18-pin DIP (300mil) Outline Dimensions**

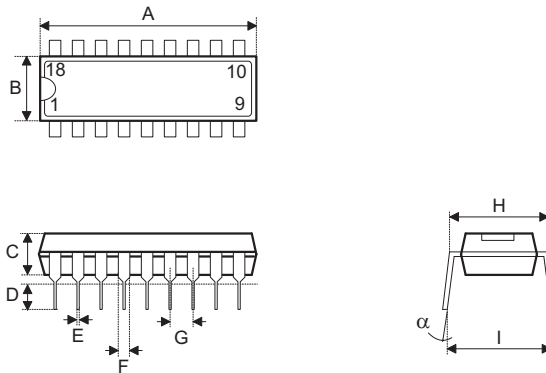

Symbol	Dimensions in mil		
	Min.	Nom.	Max.
A	895	—	915
B	240	—	260
C	125	—	135
D	125	—	145
E	16	—	20
F	50	—	70
G	—	100	—
H	295	—	315
I	335	—	375
$\alpha$	0°	—	15°

**20-pin SOP (300mil) Outline Dimensions**

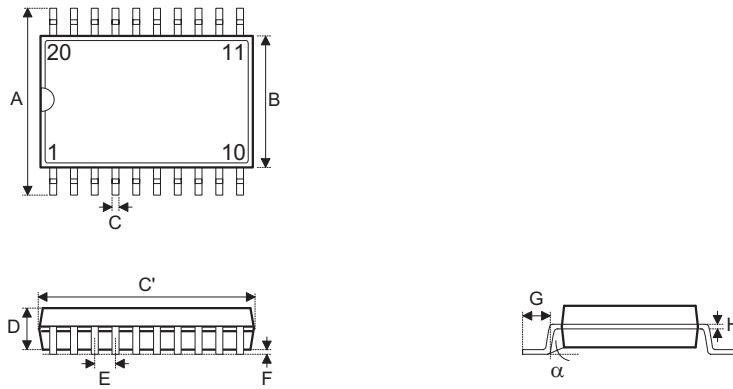

Symbol	Dimensions in mil		
	Min.	Nom.	Max.
A	394	—	419
B	290	—	300
C	14	—	20
C'	490	—	510
D	92	—	104
E	—	50	—
F	4	—	—
G	32	—	38
H	4	—	12
$\alpha$	0°	—	10°

**Product Tape and Reel Specifications**

**Reel Dimensions**

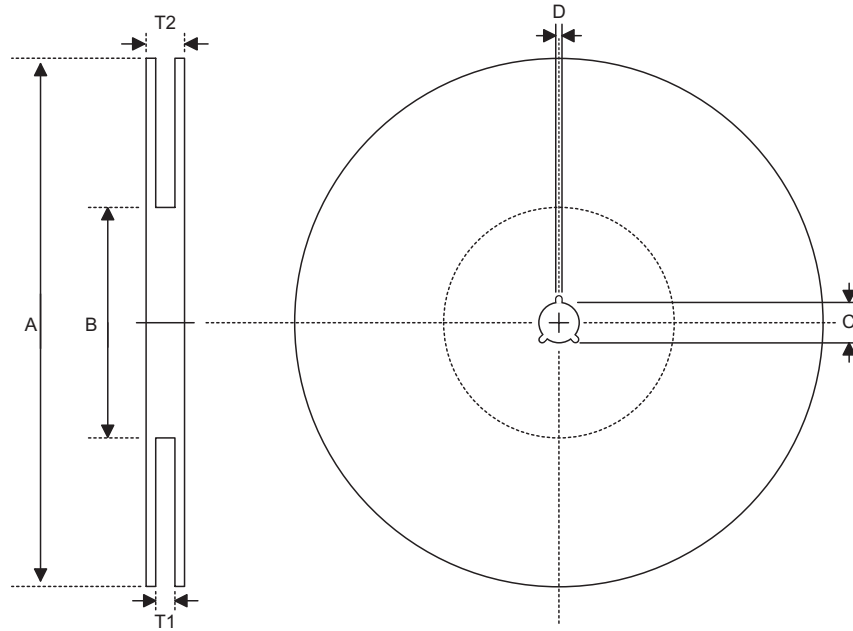

SOP 20W

Symbol	Description	Dimensions in mm
A	Reel Outer Diameter	330±1.0
B	Reel Inner Diameter	62±1.5
C	Spindle Hole Diameter	13.0+0.5 -0.2
D	Key Slit Width	2.0±0.5
T1	Space Between Flange	24.8+0.3 -0.2
T2	Reel Thickness	30.2±0.2

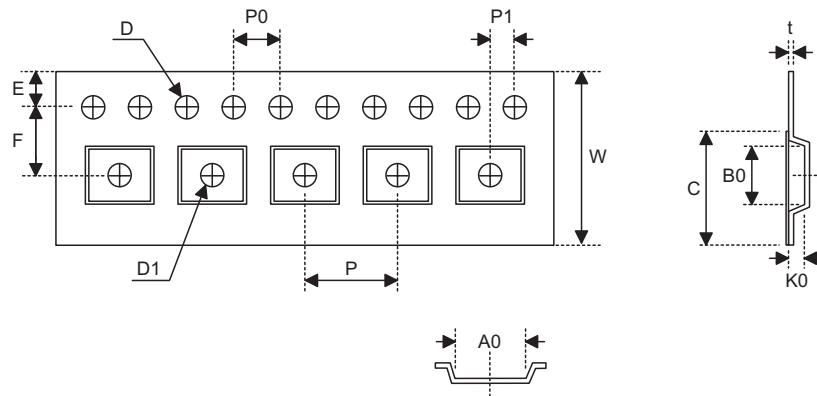
**Carrier Tape Dimensions**

**SOP 20W**

Symbol	Description	Dimensions in mm
W	Carrier Tape Width	24.0+0.3 -0.1
P	Cavity Pitch	12.0±0.1
E	Perforation Position	1.75±0.1
F	Cavity to Perforation (Width Direction)	11.5±0.1
D	Perforation Diameter	1.5+0.1
D1	Cavity Hole Diameter	1.5+0.25
P0	Perforation Pitch	4.0±0.1
P1	Cavity to Perforation (Length Direction)	2.0±0.1
A0	Cavity Length	10.8±0.1
B0	Cavity Width	13.3±0.1
K0	Cavity Depth	3.2±0.1
t	Carrier Tape Thickness	0.3±0.05
C	Cover Tape Width	21.3

**Holtek Semiconductor Inc. (Headquarters)**

No.3, Creation Rd. II, Science Park, Hsinchu, Taiwan  
Tel: 886-3-563-1999  
Fax: 886-3-563-1189  
<http://www.holtek.com.tw>

**Holtek Semiconductor Inc. (Sales Office)**

4F-2, No. 3-2, YuanQu St., Nankang Software Park, Taipei 115, Taiwan  
Tel: 886-2-2655-7070  
Fax: 886-2-2655-7373  
Fax: 886-2-2655-7383 (International sales hotline)

**Holtek Semiconductor (Shanghai) Inc.**

7th Floor, Building 2, No.889, Yi Shan Rd., Shanghai, China  
Tel: 021-6485-5560  
Fax: 021-6485-0313  
<http://www.holtek.com.cn>

**Holtek Semiconductor (Hong Kong) Ltd.**

Block A, 3/F, Tin On Industrial Building, 777-779 Cheung Sha Wan Rd., Kowloon, Hong Kong  
Tel: 852-2-745-8288  
Fax: 852-2-742-8657

**Holmate Semiconductor, Inc.**

46712 Fremont Blvd., Fremont, CA 94538  
Tel: 510-252-9880  
Fax: 510-252-9885  
<http://www.holmate.com>

Copyright © 2003 by HOLTEK SEMICONDUCTOR INC.

The information appearing in this Data Sheet is believed to be accurate at the time of publication. However, Holtek assumes no responsibility arising from the use of the specifications described. The applications mentioned herein are used solely for the purpose of illustration and Holtek makes no warranty or representation that such applications will be suitable without further modification, nor recommends the use of its products for application that may present a risk to human life due to malfunction or otherwise. Holtek's products are not authorized for use as critical components in life support devices or systems. Holtek reserves the right to alter its products without prior notification. For the most up-to-date information, please visit our web site at <http://www.holtek.com.tw>.