

HVM14SR

Silicon Epitaxial Planar PIN Diode for High Frequency Attenuator

HITACHI

Preliminary
Rev. 2
May. 1993

Features

- Low forward resistance. ($r_f = 7.0\Omega$ max)
- Low capacitance. ($C = 0.25\text{pF}$ typ)
- MPAK package is suitable for high density surface mounting and high speed assembly.

Ordering Information

Type No.	Laser Mark	Package Code
HVM14SR	H 7	MPAK

Pin Arrangement

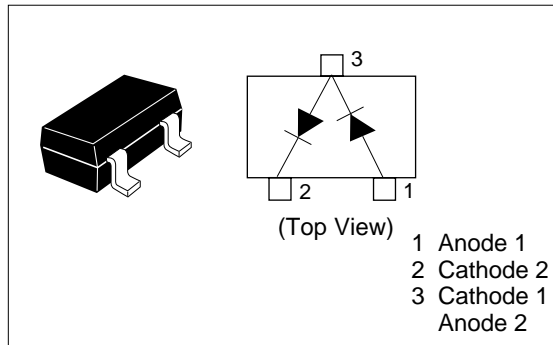

Absolute Maximum Ratings ($T_a = 25^\circ\text{C}$)

Item	Symbol	Value	Unit
Reverse voltage	V_R	50	V
Forward current	I_F	50	mA
Power dissipation	P_d^*	100	mW
Junction temperature	T_j	125	$^\circ\text{C}$
Storage temperature	T_{stg}	-55 to +125	$^\circ\text{C}$

* Per one device

Electrical Characteristics ($T_a = 25^\circ\text{C}$)

Item	Symbol	Min	Typ	Max	Unit	Test Condition
Forward voltage	V_F	—	—	1.0	V	$I_F = 50$ mA
Reverse current	I_R	—	—	100	nA	$V_R = 50$ V
Capacitance	C	—	0.25	—	pF	$V_R = 50$ V, $f = 1$ MHz
Forward resistance	r_f	—	—	7.0	Ω	$I_F = 10$ mA, $f = 100$ MHz
ESD-Capability	—	200	—	—	V	* $C = 200\text{pF}$, Both forward and reverse direction 1 pulse

* Failure criterion ; $I_R \geq 200\text{nA}$ at $V_R = 50\text{V}$

HVM14SR

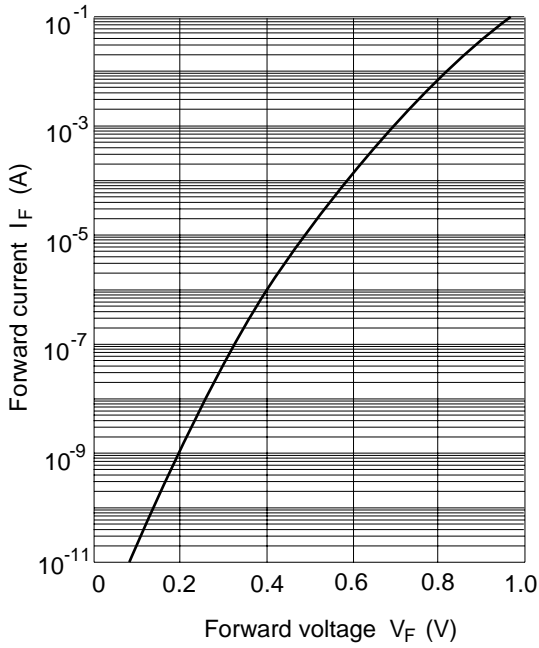

Fig.1 Forward current Vs. Forward voltage

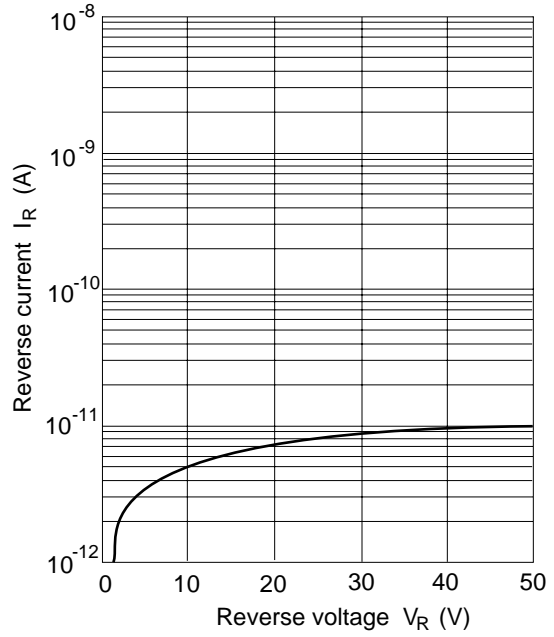

Fig.2 Reverse current Vs. Reverse voltage

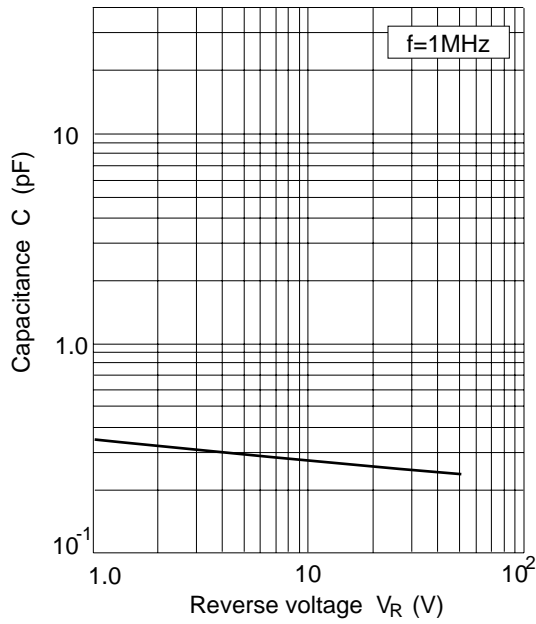

Fig.3 Capacitance Vs. Reverse voltage

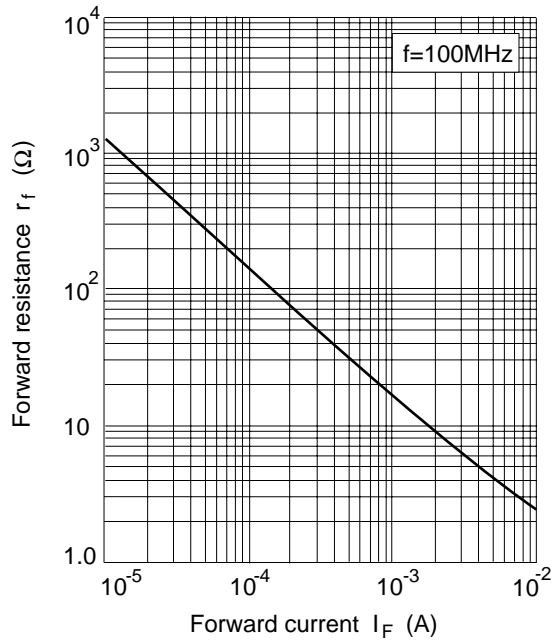

Fig.4 Forward resistance Vs. Forward current

Package Dimensions

Unit: mm

