

# HVM17 Variable Capacitance Diode for FM tuner

# HITACHI

Preliminary  
Rev. 2  
May. 1993

### Features

- Good linearity of C-V curve.
- To be usable at low voltage.
- High figure of merit. (Q=50 min)
- MPAK package is suitable for high density surface mounting and high speed assembly.

### Ordering Information

Type No.	Laser Mark	Package Code
HVM17	T 6	MPAK

### Pin Arrangement

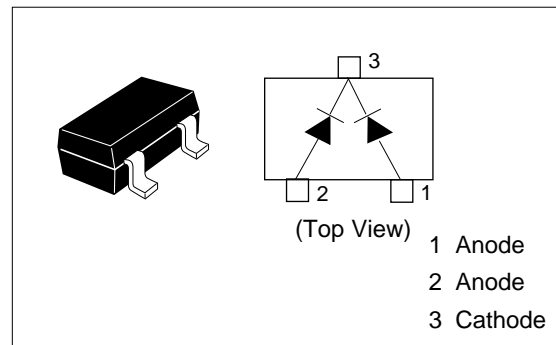

### Absolute Maximum Ratings (Ta = 25°C)

Item	Symbol	Value	Unit
Reverse voltage	$V_R$	15	V
Junction temperature	$T_j$	125	°C
Storage temperature	$T_{stg}$	-55 to +125	°C

### Electrical Characteristics (Ta = 25°C)

Item	Symbol	Min	Typ	Max	Unit	Test Condition
Reverse voltage	$V_R$	15	—	—	V	$I_R = 10 \mu A$
Reverse current	$I_R$	—	—	100	nA	$V_R = 9 V$
Capacitance	$C_1$	50.0	—	85.0	pF	$V_R = 1 V, f = 1 MHz$
	$C_3$	16.1	—	27.3		$V_R = 3 V, f = 1 MHz$
	$C_{4.5}$	5.23	—	8.84		$V_R = 4.5V, f = 1 MHz$
Capacitance ratio	n	5.6	—	—	—	$C_1/C_{4.5}$
Figure of merit	Q	50	—	—	—	$V_R = 2.5V, f = 10 MHz$
ESD-Capability	—	80	—	—	V	*C= 200pF, Both forward and reverse direction 1 pulse.

\* Failure criterion ;  $I_R \geq 100nA$  at  $V_R = 9V$

## HVM17

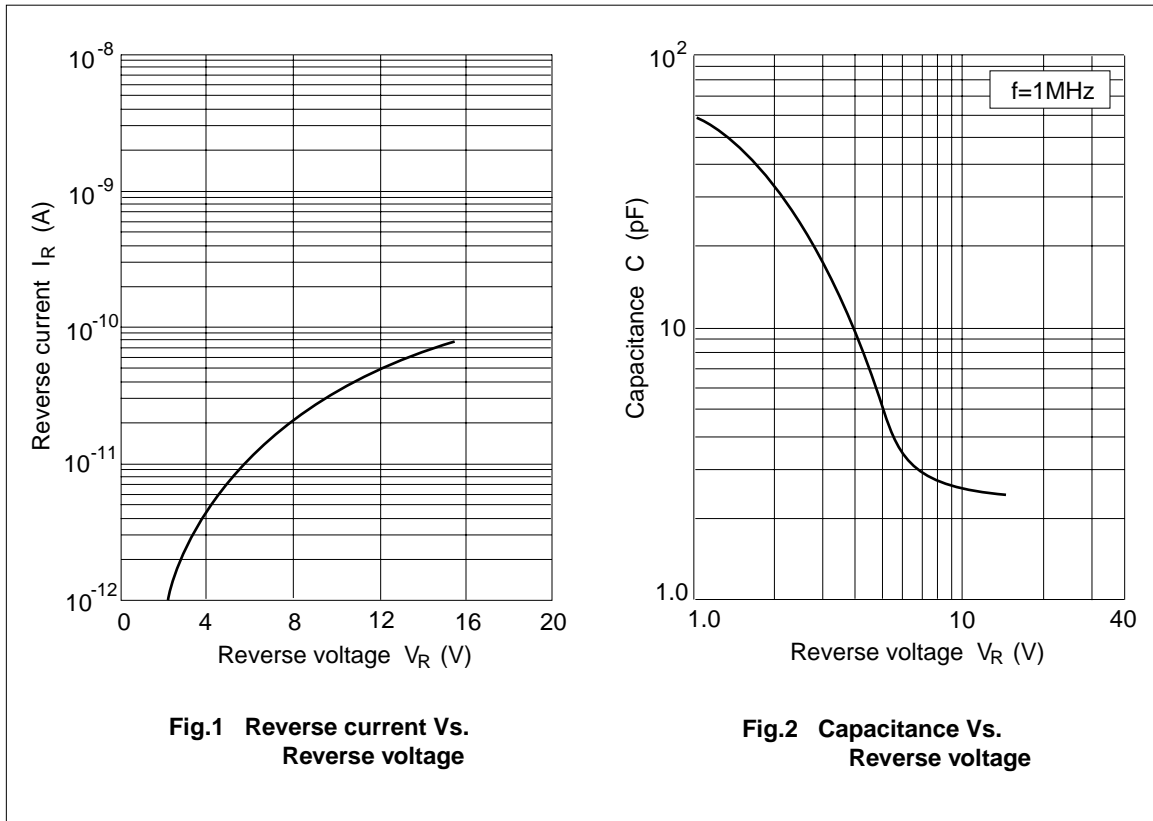

### Package Dimensions

Unit: mm

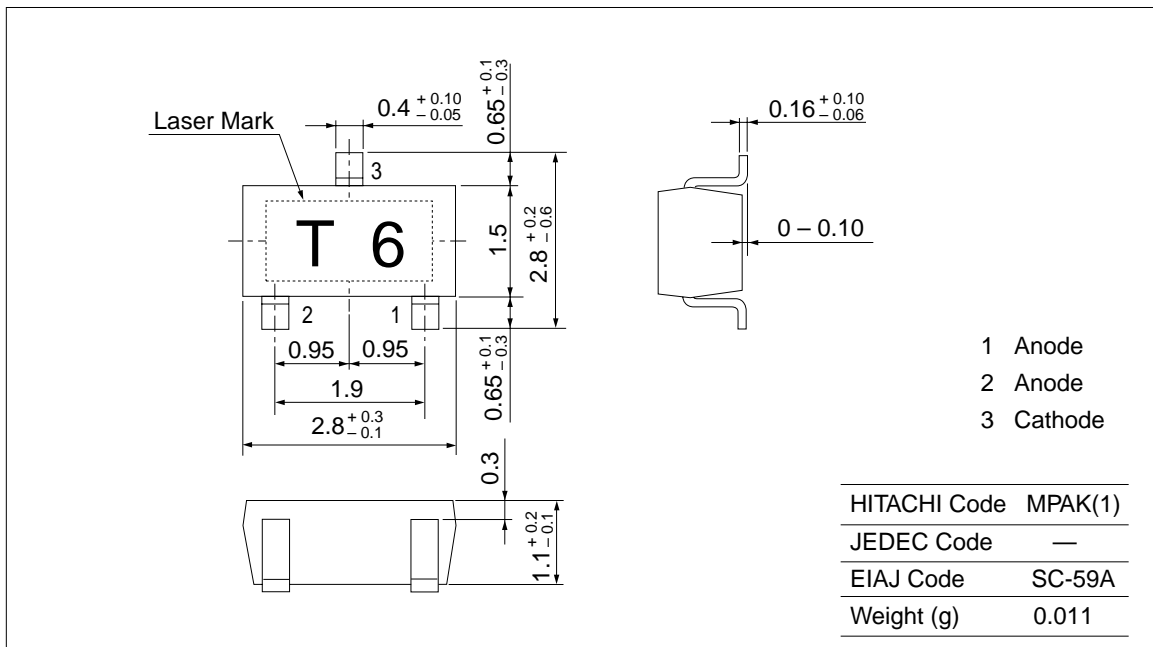

# HVM17WA

## Variable Capacitance Diode for VCO

HITACHI

Rev. 0  
May. 1994

### Features

- Good linearity of C-V curve.
- To be usable at low voltage.
- High figure of merit. (Q=50 min)
- MPAK package is suitable for high density surface mounting and high speed assembly.

### Ordering Information

Type No.	Laser Mark	Package Code
HVM17WA	T 11	MPAK

### Pin Arrangement

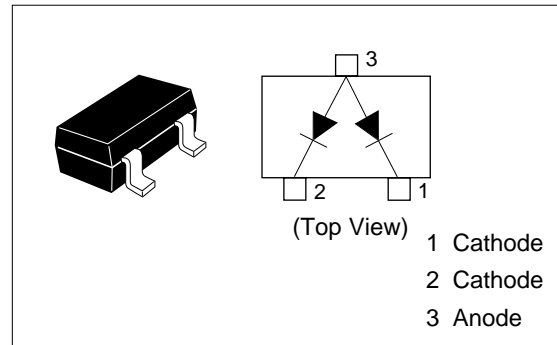

### Absolute Maximum Ratings (Ta = 25°C)

Item	Symbol	Value	Unit
Reverse voltage	$V_R$	15	V
Junction temperature	$T_j$	125	°C
Storage temperature	$T_{stg}$	-55 to +125	°C

### Electrical Characteristics (Ta = 25°C)

Item	Symbol	Min	Typ	Max	Unit	Test Condition
Reverse voltage	$V_R$	15	—	—	V	$I_R = 10 \mu A$
Reverse current	$I_R$	—	—	100	nA	$V_R = 9 V$
Capacitance	$C_1$	50.0	—	85.0	pF	$V_R = 1 V, f = 1 MHz$
	$C_3$	16.1	—	27.3		$V_R = 3 V, f = 1 MHz$
	$C_{4.5}$	5.23	—	8.84		$V_R = 4.5V, f = 1 MHz$
Capacitance ratio	n	5.6	—	—	—	$C_1/C_{4.5}$
Figure of merit	Q	50	—	—	—	$V_R = 2.5V, f = 10 MHz$
ESD-Capability	—	80	—	—	V	*C= 200pF, Both forward and reverse direction 1 pulse.

\* Failure criterion ;  $I_R \geq 100nA$  at  $V_R = 9V$

\*\* Peronedevice

## HVM17WA

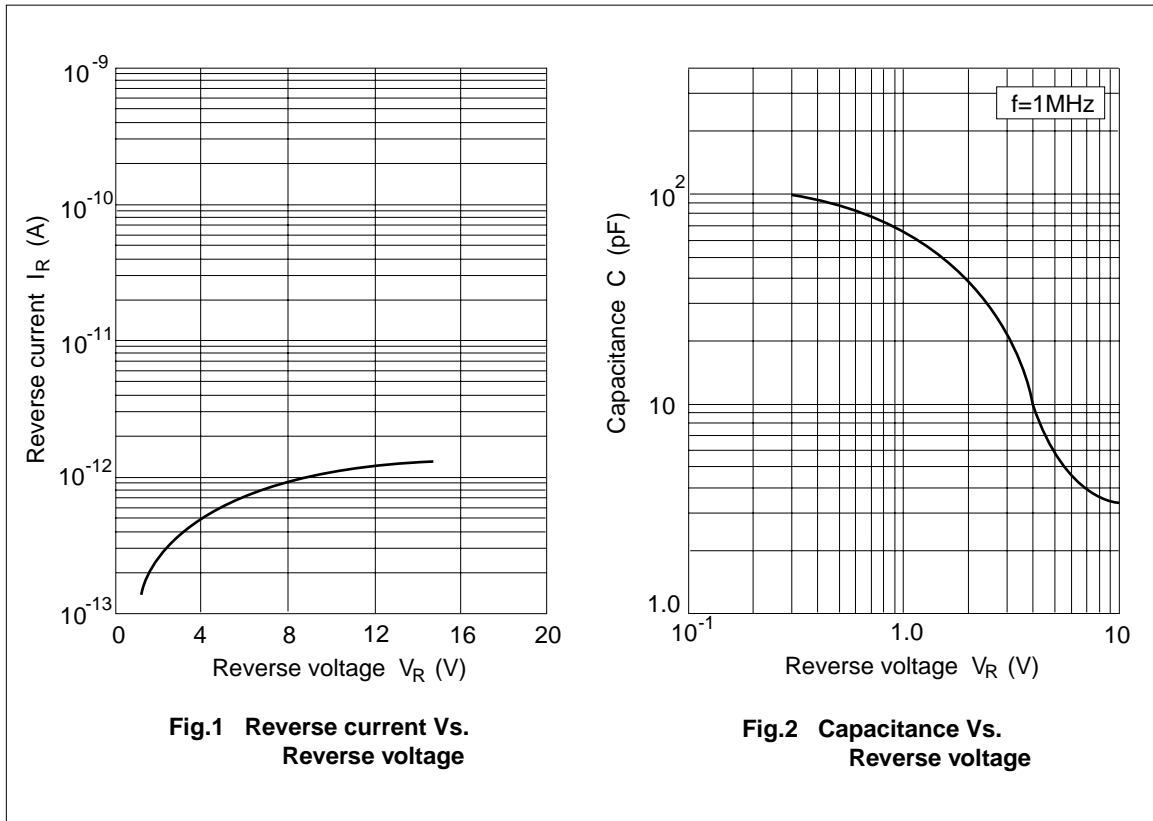

### Package Dimensions

Unit: mm

