

# HVM187WK

## Silicon Epitaxial Planar PIN Diode for High Frequency Attenuator

# HITACHI

Preliminary  
Rev. 5  
Jun. 1993

### Features

- Low forward resistance. ( $r_f = 5.5\Omega$  max)
- MPAK package is suitable for high density surface mounting and high speed assembly.

### Ordering Information

Type No.	Laser Mark	Package Code
HVM187WK	H 1	MPAK

### Pin Arrangement

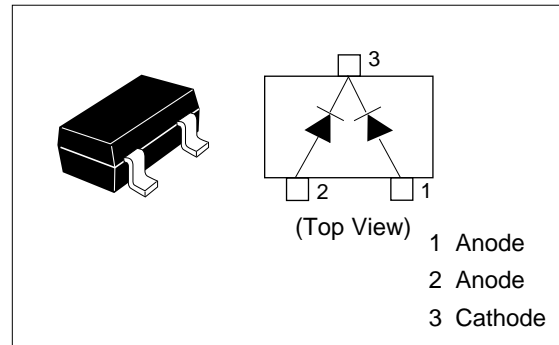

### Absolute Maximum Ratings ( $T_a = 25^\circ\text{C}$ )

Item	Symbol	Value	Unit
Reverse voltage	$V_R$	60	V
Forward current	$I_F$	50	mA
Power dissipation	$P_d^*$	100	mW
Junction temperature	$T_j$	125	$^\circ\text{C}$
Storage temperature	$T_{stg}$	-55 to +125	$^\circ\text{C}$

\* Per one device

### Electrical Characteristics ( $T_a = 25^\circ\text{C}$ )

Item	Symbol	Min	Typ	Max	Unit	Test Condition
Forward voltage	$V_F$	—	—	1.0	V	$I_F = 10$ mA
Reverse current	$I_R$	—	—	100	nA	$V_R = 60$ V
Capacitance	C	—	—	2.4	pF	$V_R = 0$ V, $f = 1$ MHz
Forward resistance	$r_f$	3.5	—	5.5	$\Omega$	$I_F = 10$ mA, $f = 100$ MHz
ESD-Capability	—	200	—	—	V	*C=200pF, Both forward and reverse direction 1 pulse

\* Failure criterion ;  $I_R \geq 100\text{nA}$  at  $V_R = 60\text{V}$ .

## HVM187WK

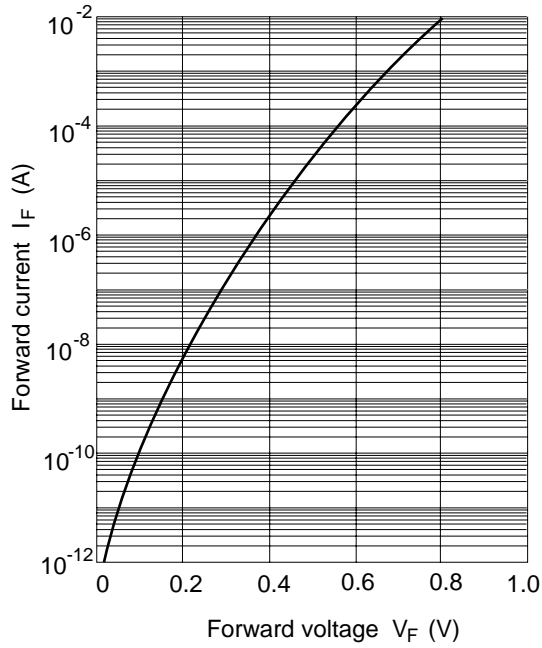

**Fig.1 Forward current Vs. Forward voltage**

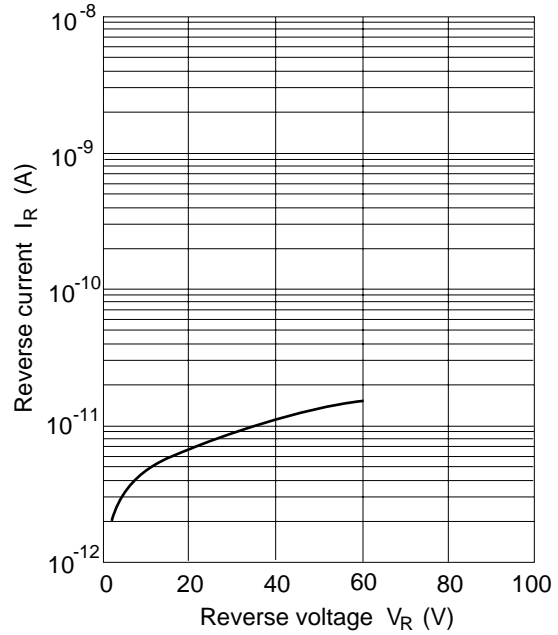

**Fig.2 Reverse current Vs. Reverse voltage**

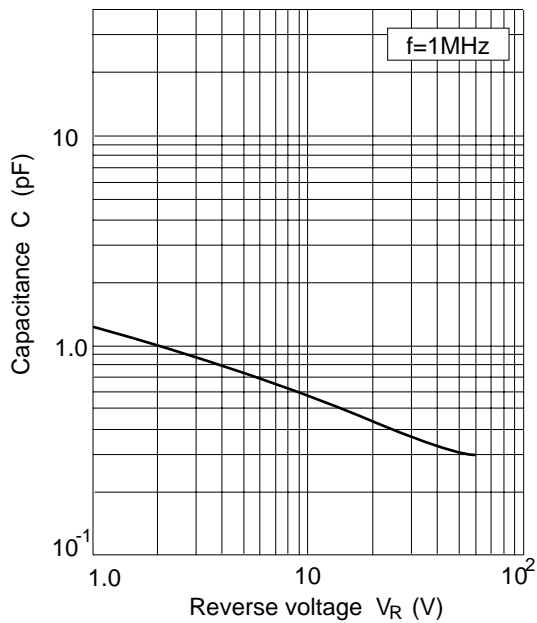

**Fig.3 Capacitance Vs. Reverse voltage**

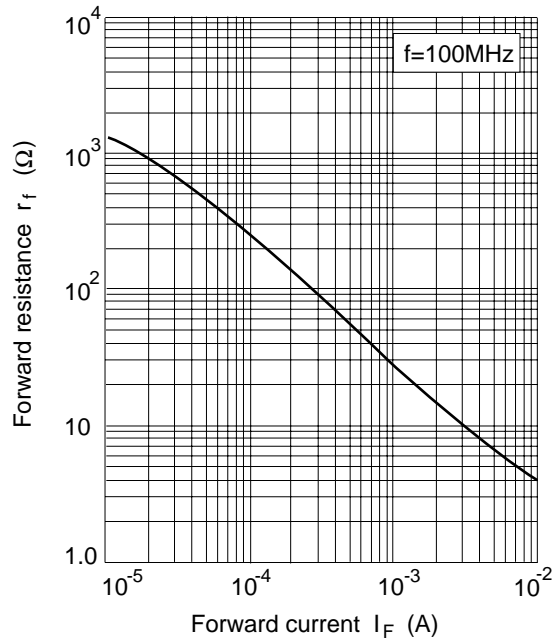

**Fig.4 Forward resistance Vs. Forward current**

### Package Dimensions

Unit: mm

