

**SINGLE OPERATIONAL AMPLIFIER**

The KA201A and KA301A are general-purpose operational amplifiers which are externally phase compensated, permit a choice of operation for optimum high-frequency performance at a selected gain: unity-gain compensation can be obtained with a single capacitor.

**FEATURES**

- Short-circuit protection and latch-free operation
- Slew rate of 10V/ $\mu$ s as a summing amplifier
- Class AB output provides excellent linearity
- Low bias current

**BLOCK DIAGRAM**

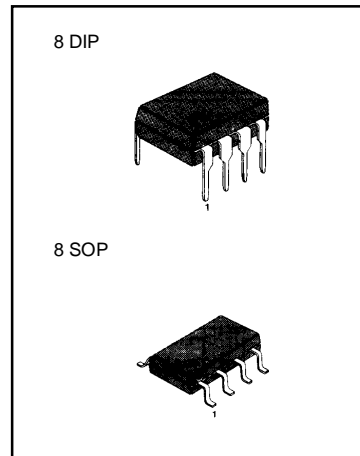
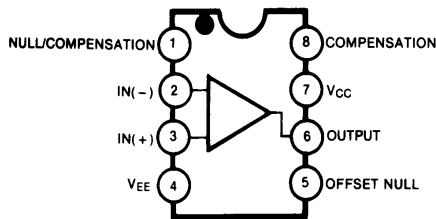

**ORDERING INFORMATION**

Device	Package	Operating Temperature
KA301A	8 DIP	0 ~ +70 °C
KA201A		-25 ~ +85 °C
KA301AD	8 DIP	0 ~ +70 °C
KA201AD		-25 ~ +85 °C

**SCHEMATIC DIAGRAM**

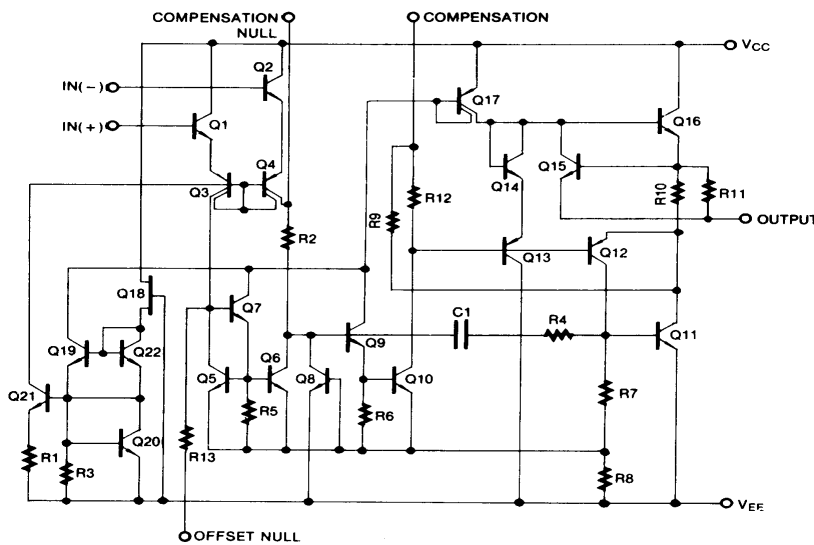

## ABSOLUTE MAXIMUM RATINGS

Characteristic	Symbol	KA201A	KA301A	Unit
Supply Voltage	$V_{CC}$	$\pm 22$	$\pm 18$	V
Differential Input Voltage	$V_{I(OFF)}$	$\pm 30$	$\pm 30$	V
Input Voltage	$V_I$	$\pm 15$	$\pm 15$	V
Output short Circuit Duration		Continuous	Continuous	
Power Dissipation	$P_D$	500	500	mW
Operating Temperature Range	$T_{OPR}$	-25 ~ +85	0 ~ +70	$^{\circ}C$
Storage Temperature Range	$T_{STG}$	-65 ~ +150	-65 ~ +150	$^{\circ}C$

## ELECTRICAL CHARACTERISTICS

(T<sub>A</sub> = +25 $^{\circ}C$ , V<sub>CC</sub> = +15V, V<sub>EE</sub> = -15V, unless otherwise specified)

Characteristic	Symbol	Test Conditions	KA201A			KA301A			Unit
			Min	Typ	Max	Min	Typ	Max	
Input Offset Voltage	$V_{IO}$	$R_S \leq 50K\Omega$		0.5	2.0		2.0	7.5	mV
		NOTE 1			3			10	mV
Input Offset Current	$I_{IO}$			1.5	10		4.5	50	nA
		NOTE 1			20			70	nA
Input Bias Current	$I_{BIAS}$			40	75		60	250	nA
		NOTE 1			100			300	nA
Supply Current	$I_{CC}$	$V_{CC} = \pm 20V$		2.0	3.0				mA
		$V_{CC} = \pm 15V$					2.0	3.0	mA
		$V_{CC} = \pm 20V, T_A = T_{A(MAX)}$		1.7	2.5				mA
Large Signal Voltage Gain	$G_V$	$V_{CC} = \pm 15V, R_L \geq 2K\Omega, V_{O(P,P)} = \pm 10V$	50	160		25	160		V/mV
		NOTE 1	25			15			V/mV
Average Temperature Coefficient of Input Offset Voltage	$\Delta V_{IO}/\Delta T$	NOTE 1		3.0	15		6.0	30	$\mu V/^{\circ}C$
Average Temperature Coefficient of Input Offset Current	$\Delta I_{IO}/\Delta T$	$25^{\circ}C \leq T_A \leq T_{A(MAX)}$		0.01	0.1		0.01	0.3	nA/ $^{\circ}C$
		$T_{A(MIN)} \leq T_A \leq 25^{\circ}C$		0.02	0.2		0.02	0.6	nA/ $^{\circ}C$
Input Voltage Range	$V_{I(R)}$	$V_{CC} = \pm 20V$	NOTE 1	$\pm 15$					V
		$V_{CC} = \pm 15V$	NOTE 1				$\pm 12$		V
Common-Mode Rejection Ratio	CMRR	$R_S \leq 50K\Omega$	NOTE 1	80	100		70	95	dB
Power Supply Rejection Ratio	PSRR	$R_S \leq 50K\Omega$	NOTE 1	80	100		70	100	dB
Output Voltage Swing	$V_{O(P,P)}$	$V_{CC} = \pm 15V$	$R_L = 10K\Omega$	$\pm 12$	$\pm 14$		$\pm 12$	$\pm 14$	V
			$R_L = 2.0K\Omega$	$\pm 10$	$\pm 13$		$\pm 10$	$\pm 13$	V
Input Resistance	$R_I$			1.5	4.0		0.5	2.0	M $\Omega$

NOTE 1. KA201A: -25 $\leq T_A \leq$  +85 $^{\circ}C$   
KA301A: 0 $\leq T_A \leq$  +70 $^{\circ}C$

TYPICAL PERFORMANCE CHARACTERISTICS

Fig. 1 SUPPLY CURRENT

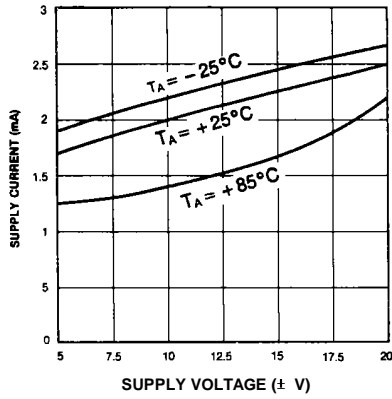

Fig. 2 VOLTAGE GAIN

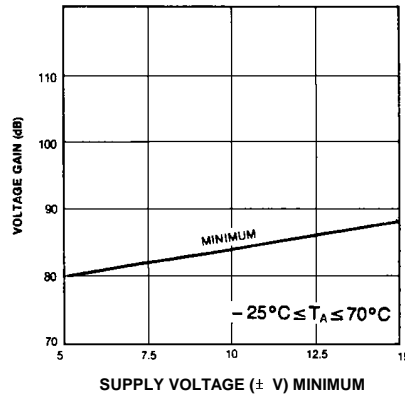

Fig. 3 CURRENT LIMITING

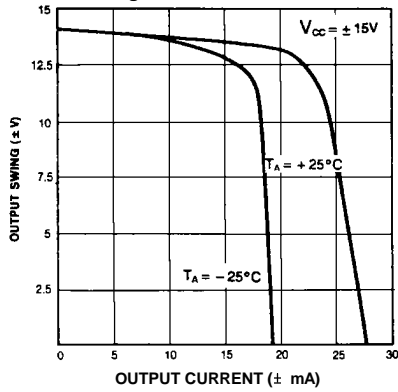

Fig. 4 INPUT CURRENT

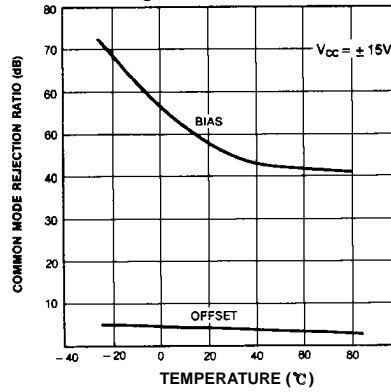

Fig. 5 POWER SUPPLY REJECTION

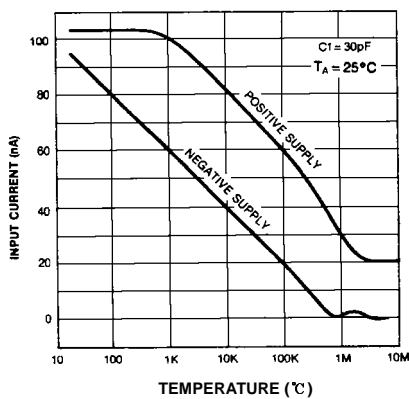
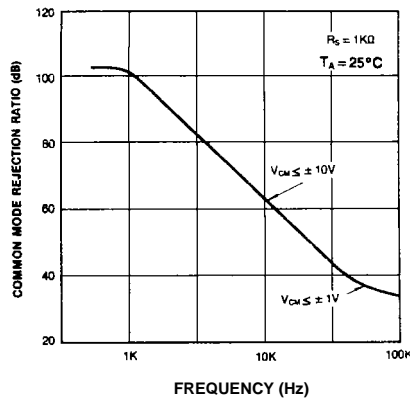

Fig. 6 COMMON MOOE REJECTION



## TRADEMARKS

The following are registered and unregistered trademarks Fairchild Semiconductor owns or is authorized to use and is not intended to be an exhaustive list of all such trademarks.

ACEx™	ISOPLANAR™	UHC™
CoolFET™	MICROWIRE™	VCX™
CROSSVOLT™	POP™	
E <sup>2</sup> CMOS™	PowerTrench™	
FACT™	QST™	
FACT Quiet Series™	Quiet Series™	
FAST®	SuperSOT™-3	
FASTr™	SuperSOT™-6	
GTO™	SuperSOT™-8	
HiSeC™	TinyLogic™	

## DISCLAIMER

FAIRCHILD SEMICONDUCTOR RESERVES THE RIGHT TO MAKE CHANGES WITHOUT FURTHER NOTICE TO ANY PRODUCTS HEREIN TO IMPROVE RELIABILITY, FUNCTION OR DESIGN. FAIRCHILD DOES NOT ASSUME ANY LIABILITY ARISING OUT OF THE APPLICATION OR USE OF ANY PRODUCT OR CIRCUIT DESCRIBED HEREIN; NEITHER DOES IT CONVEY ANY LICENSE UNDER ITS PATENT RIGHTS, NOR THE RIGHTS OF OTHERS.

## LIFE SUPPORT POLICY

FAIRCHILD'S PRODUCTS ARE NOT AUTHORIZED FOR USE AS CRITICAL COMPONENTS IN LIFE SUPPORT DEVICES OR SYSTEMS WITHOUT THE EXPRESS WRITTEN APPROVAL OF FAIRCHILD SEMICONDUCTOR CORPORATION. As used herein:

1. Life support devices or systems are devices or systems which, (a) are intended for surgical implant into the body, or (b) support or sustain life, or (c) whose failure to perform when properly used in accordance with instructions for use provided in the labeling, can be reasonably expected to result in significant injury to the user.
2. A critical component is any component of a life support device or system whose failure to perform can be reasonably expected to cause the failure of the life support device or system, or to affect its safety or effectiveness.

## PRODUCT STATUS DEFINITIONS

### Definition of Terms

Datasheet Identification	Product Status	Definition
Advance Information	Formative or In Design	This datasheet contains the design specifications for product development. Specifications may change in any manner without notice.
Preliminary	First Production	This datasheet contains preliminary data, and supplementary data will be published at a later date. Fairchild Semiconductor reserves the right to make changes at any time without notice in order to improve design.
No Identification Needed	Full Production	This datasheet contains final specifications. Fairchild Semiconductor reserves the right to make changes at any time without notice in order to improve design.
Obsolete	Not In Production	This datasheet contains specifications on a product that has been discontinued by Fairchild semiconductor. The datasheet is printed for reference information only.