

# KA2110

## LINEAR INTEGRATED CIRCUIT

### TV VIDEO IF AMPLIFIER WITH AGC AND KEYER

The KA2110 is a monolithic Video IF amplifier with a complete gated wide range AGC system for use as the 1st and 2nd Video IF stages and AGC keyer and amplifier in color or monochrome television receivers.

- Power Gain 46dB TYP at  $f = 58\text{MHz}$
- Wide AGC Range 60dB MIN.
- Control Signal Available for Delayed Forward AGC of Tuner.
- High-Gain Gated AGC system for either positive or negative going video signal.
- Single-Polarity Power Supply Operation

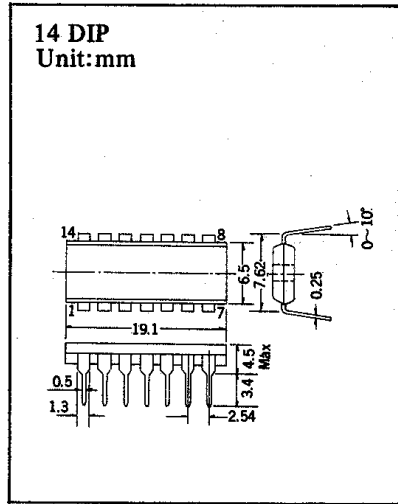

### TYPICAL APPLICATION CIRCUIT FOR MONOCHROME TELEVISION RECEIVER

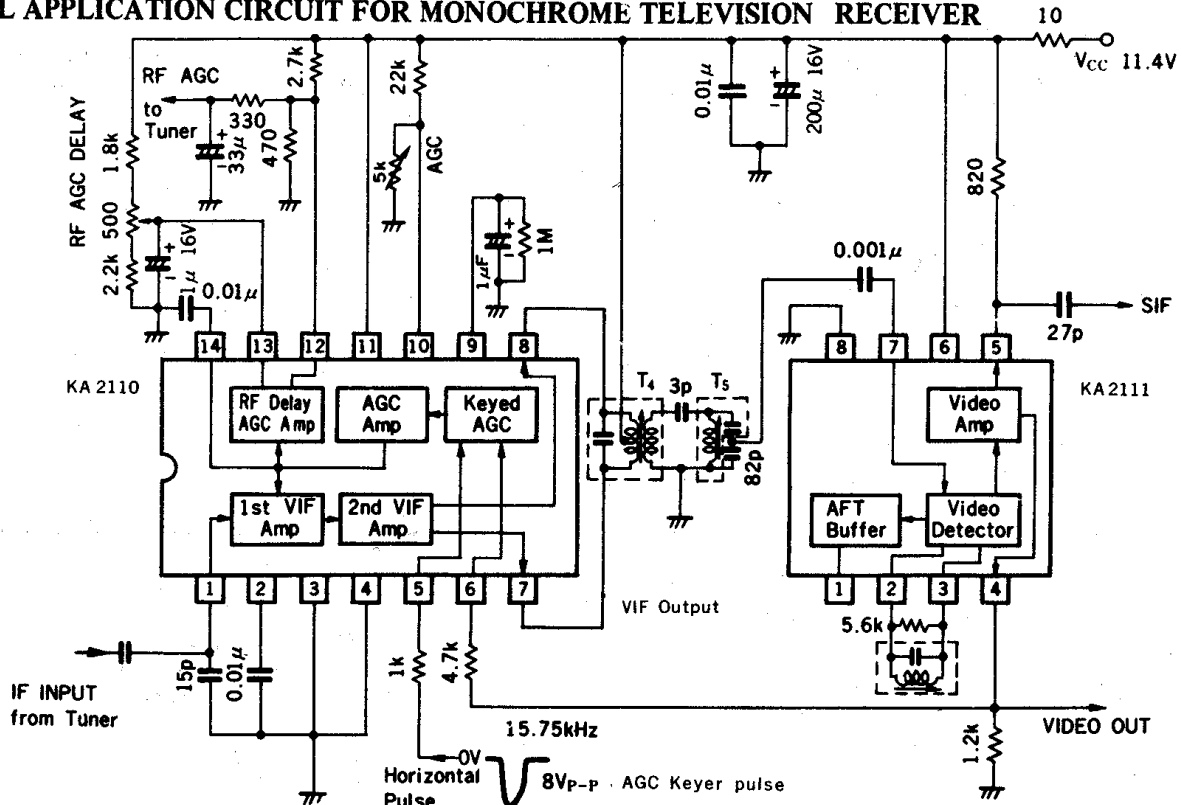

### AGC APPLICATION CHART

Video Polarity	Pin 6 Voltage	Pin 10 Voltage	Pin 5 Serial R
Negative Going Sync.	5.5V 2.0V 0V	Adj. 1.0~4.0 Vdc Nom. 2.0 V	0
Positive Going Sync.	Adj. 1.0~8.0 Vdc Nom. 4.5V	4.5V 0V	3.9k

