

QUAD OPERATIONAL AMPLIFIERS

The KA248/LM348 is a true quad LM741. It consists of four independent, high-gain, internally compensated, low-power operational amplifiers which have been designed to provide functional characteristics identical to those of the familiar LM741 operational amplifier. In addition the total supply current for all four amplifiers is comparable to the Supply current of a single LM741 type OP Amp.

Other features include input offset currents and input bias current which are much less than those of a standard LM741. Also, excellent isolation between amplifiers has been achieved by independently biasing each amplifier and using layout techniques which minimize thermal coupling.

FEATURES

- LM741 OP Amp operating characteristics
- Low supply current drain
- Class AB output stage-no crossover distortion
- Pin compatible with the LM324 & KA3403
- Low input offset voltage: 1mV Typ.
- Low input offset current: 4nA Typ.
- Low input bias current: 30nA Typ.
- Gain bandwidth product for LM348 (unity gain): 1.0MHz Typ.
- High degree of isolation between amplifiers: 120dB
- Overload protection for inputs and outputs

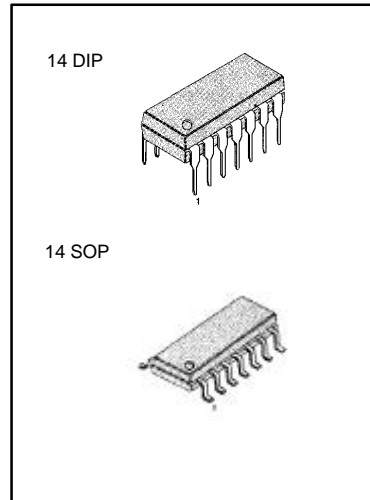

BLOCK DIAGRAM

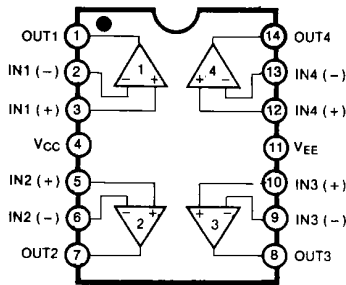

ORDERING INFORMATION

Device	Package	Operating Temperature
LM348N (KA348)	14 DIP	0 ~ +70°C
KA348D	14 SOP	
KA248	14 DIP	-25 ~ +85 °C
KA248D	14 SOP	

SCHEMATIC DIAGRAM (One Section Only)

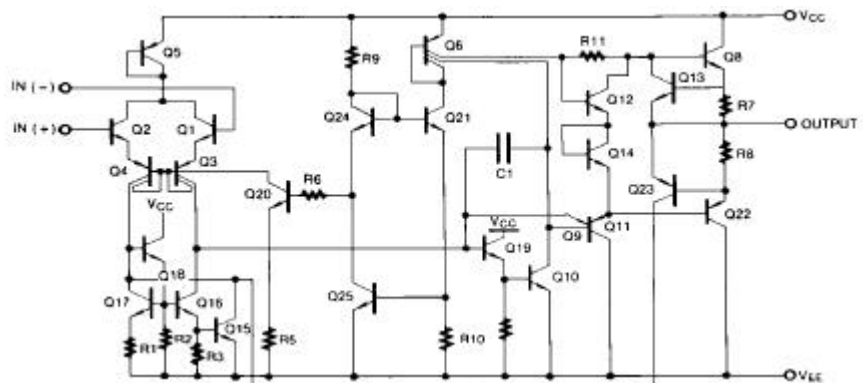

ABSOLUTE MAXIMUM RATINGS ($T_A = 25^\circ\text{C}$)

Characteristic	Symbol	Value	Unit
Supply Voltage	V_{CC}	± 18	V
Differential Input Voltage	$V_{I(DIFF)}$	36	V
Input Voltage	V_I	± 18	V
Output Short Circuit Duration		Continuous	
Operating Temperature KA248	T_{OPR}	- 25 ~ +85	$^\circ\text{C}$
KA348		0~ +70	$^\circ\text{C}$
Storage Temperature	T_{STG}	- 65~ +150	$^\circ\text{C}$

ELECTRICAL CHARACTERISTICS

($V_{CC} = 15\text{V}$, $V_{EE} = -15\text{V}$, $T_A = 25^\circ\text{C}$, unless otherwise specified)

Characteristic	Symbol	Test Conditions	LM248			LM348			Unit
			Min	Typ	Max	Min	Typ	Max	
Input Offset Voltage	V_{IO}	$R_S \leq 10\text{K}\Omega$		1	6.0		1	6.0	mV
			NOTE 1		7.5		7.5		
Input Offset Current	I_{IO}			4	50		4	50	nA
			NOTE 1		125		100		
Input Bias Current	I_{BIAS}			30	200		30	200	nA
			NOTE 1		500		400		
Input Resistance	R_I		0.8	2.5		0.8	2.5	$\text{M}\Omega$	
Supply Current (all Amplifiers)	I_{CC}			2.4	4.5		2.4	4.5	mA
Large Signal Voltage Gain	G_V	$R_L \geq 2\text{K}\Omega$		25	160		25	160	V/mV
			NOTE 1	15			15		
Channel Separation	CS	$f = 1\text{KHz to } 20\text{KHz}$		120			120		dB
Common Mode Input Voltage Range	$V_{I(R)}$	NOTE 1		± 12			± 12		V
Small Signal Bandwidth	BW	$G_V = 1$		1.0			1.0		MHz
Phase Margin	MPH	$G_V = 1$		60			60		Degree
Slew Rate	SR	$G_V = 1$		0.5			0.5		$\text{V}/\mu\text{s}$
Output Short Circuit Current	I_{SC}			25			25		mA
Output Voltage Swing	$V_{O(IP,P)}$	$R_L \geq 10\text{K}\Omega$	NOTE 1	± 12	± 13		± 12	± 13	V
		$R_L \geq 2\text{K}\Omega$		± 10	± 12		+0	± 12	
Common Mode Rejection Ratio	CMRR	$R_S \geq 10\text{K}\Omega$	NOTE 1	70	90		70	90	dB
Power Supply Rejection Ratio	PSRR	$R_S \geq 10\text{K}\Omega$	NOTE 1	77	96		77	96	dB

NOTE 1

LM348: $0 \leq T_A \leq +70^\circ\text{C}$

LM248: $-25 \leq T_A \leq +85^\circ\text{C}$

TYPICAL PERFORMANCE CHARACTERISTICS

Fig. 1 SUPPLY CURRENT

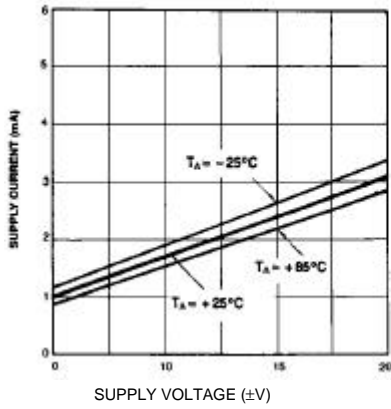

Fig. 2 VOLTAGE SWING

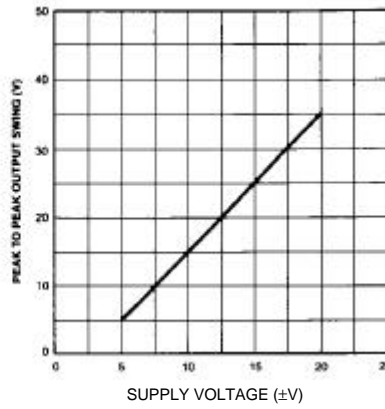

Fig. 3 SOURCE CURRENT LIMIT

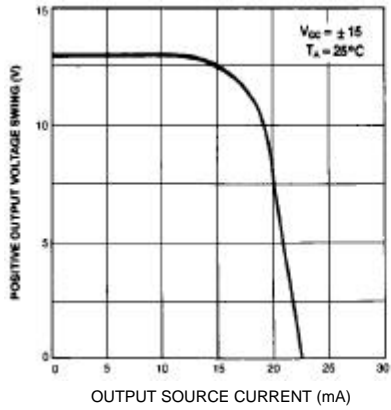

Fig. 4 SINK CURRENT LIMIT

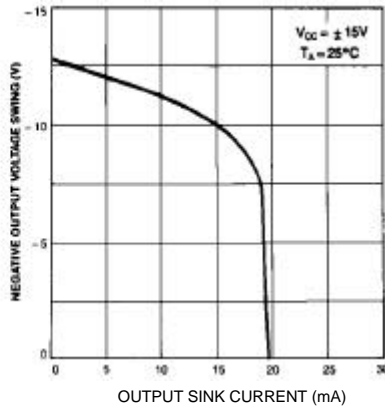

Fig. 5 OUTPUT IMPEDANCE

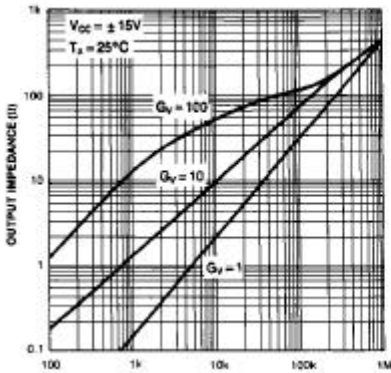

Fig. 6 COMMON-MODE REJECTION RATIO

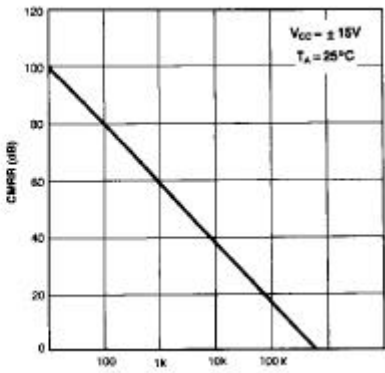

Fig. 7 OPEN LOOP FREQUENCY RESPONSE

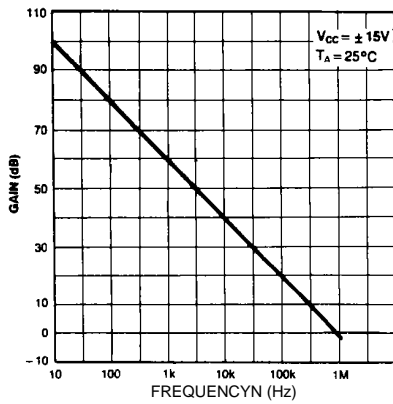

Fig. 8 BODE PLOT

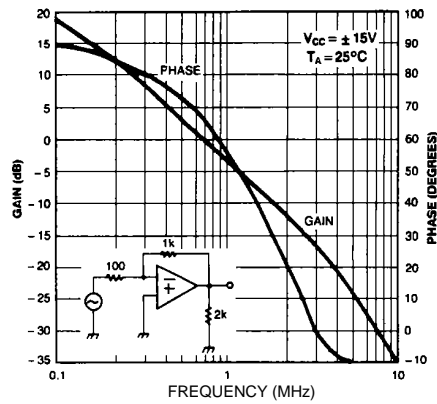

Fig. 9 LARGE SIGNAL PULSE RESPONSE

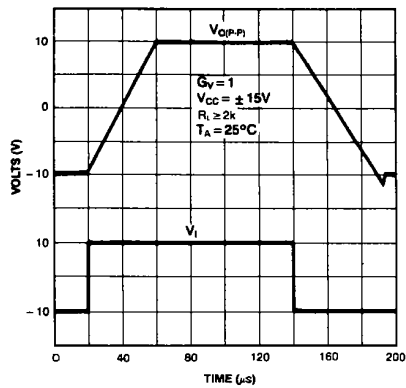

Fig. 10 SMALL SIGNAL PULSE RESPONSE

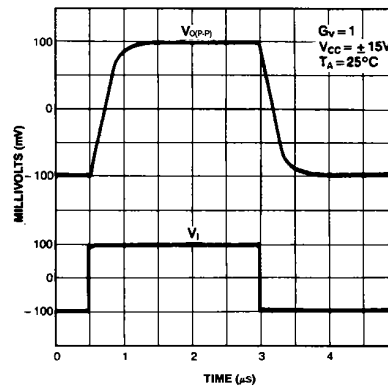

Fig. 11 UNDISTORTED OUTPUT VOLTAGE SWING

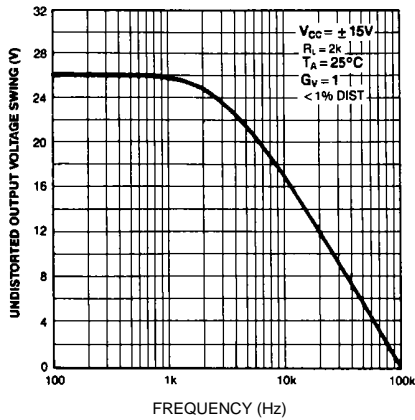

Fig. 12 INVERTING LARGE SIGNAL PULSE RESPONSE

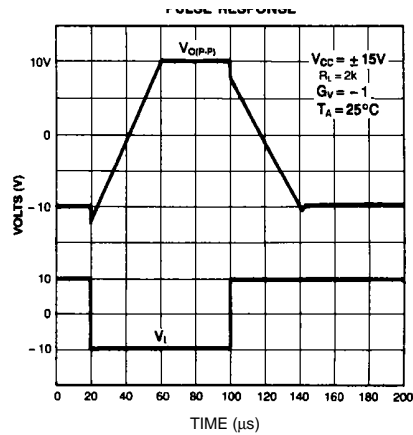

Fig. 13 INPUT NOISE VOLTAGE AND NOISE CURRENT

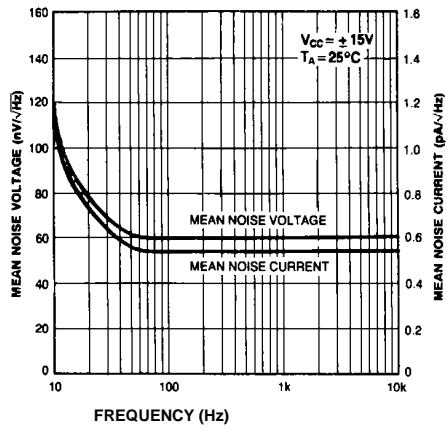

Fig. 14 POSITIVE COMMON MODE INPUT VOLTAGE LIMIT

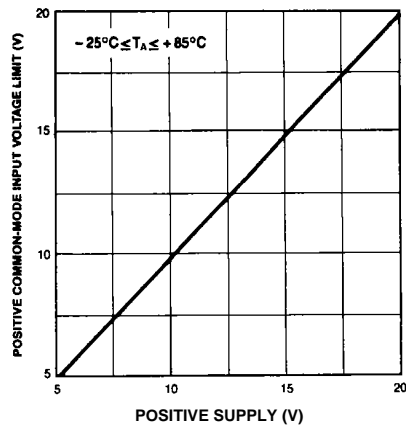
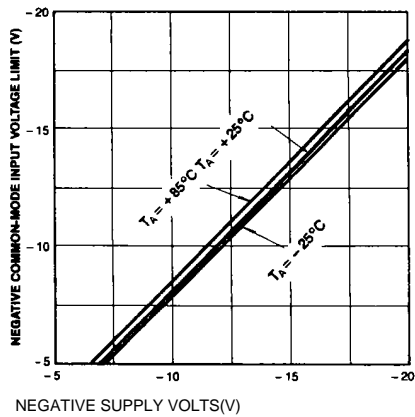

Fig. 15 NEGATIVE COMMON-MODE INPUT VOLTAGE LIMIT



TRADEMARKS

The following are registered and unregistered trademarks Fairchild Semiconductor owns or is authorized to use and is not intended to be an exhaustive list of all such trademarks.

ACE _x TM	ISOPLANAR TM	TinyLogic TM
CoolFET TM	MICROWIRE TM	UHC TM
CROSSVOLT TM	POP TM	VCX TM
E ² CMOS TM	PowerTrench [®]	
FACT TM	QFET TM	
FACT Quiet Series TM	QS TM	
FAST [®]	Quiet Series TM	
FAST _r TM	SuperSOT TM -3	
GTO TM	SuperSOT TM -6	
HiSeC TM	SuperSOT TM -8	

DISCLAIMER

FAIRCHILD SEMICONDUCTOR RESERVES THE RIGHT TO MAKE CHANGES WITHOUT FURTHER NOTICE TO ANY PRODUCTS HEREIN TO IMPROVE RELIABILITY, FUNCTION OR DESIGN. FAIRCHILD DOES NOT ASSUME ANY LIABILITY ARISING OUT OF THE APPLICATION OR USE OF ANY PRODUCT OR CIRCUIT DESCRIBED HEREIN; NEITHER DOES IT CONVEY ANY LICENSE UNDER ITS PATENT RIGHTS, NOR THE RIGHTS OF OTHERS.

LIFE SUPPORT POLICY

FAIRCHILD'S PRODUCTS ARE NOT AUTHORIZED FOR USE AS CRITICAL COMPONENTS IN LIFE SUPPORT DEVICES OR SYSTEMS WITHOUT THE EXPRESS WRITTEN APPROVAL OF FAIRCHILD SEMICONDUCTOR CORPORATION.
As used herein:

1. Life support devices or systems are devices or systems which, (a) are intended for surgical implant into the body, or (b) support or sustain life, or (c) whose failure to perform when properly used in accordance with instructions for use provided in the labeling, can be reasonably expected to result in significant injury to the user.
2. A critical component is any component of a life support device or system whose failure to perform can be reasonably expected to cause the failure of the life support device or system, or to affect its safety or effectiveness.

PRODUCT STATUS DEFINITIONS

Definition of Terms

Datasheet Identification	Product Status	Definition
Advance Information	Formative or In Design	This datasheet contains the design specifications for product development. Specifications may change in any manner without notice.
Preliminary	First Production	This datasheet contains preliminary data, and supplementary data will be published at a later date. Fairchild Semiconductor reserves the right to make changes at any time without notice in order to improve design.
No Identification Needed	Full Production	This datasheet contains final specifications. Fairchild Semiconductor reserves the right to make changes at any time without notice in order to improve design.
Obsolete	Not In Production	This datasheet contains specifications on a product that has been discontinued by Fairchild semiconductor. The datasheet is printed for reference information only.