

LOW DROPOUT VOLTAGE REGULATOR

The KA278R12 is a low-dropout voltage regulator suitable for various electronic equipments. It provide constant voltage power source with TO-220 4 lead full mold package. Dropout voltage of KA278R12 is below 0.5v in full rated current(2A). This regulator has various function such as peak current protection, thermal shut down, overvoltage protection and output disable function.

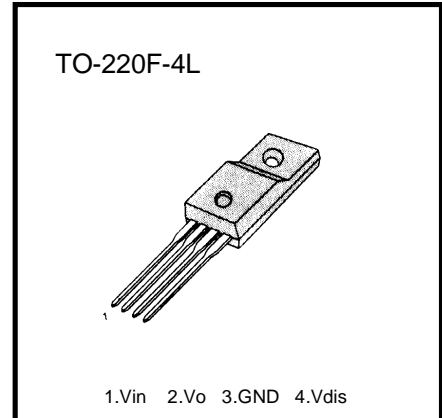

FEATURES

- 2A / 12V Output low dropout voltage regulator
- TO220 Full-Mold package (4PIN)
- Overcurrent protection, Thermal shutdown
- Overvoltage protection, Shortcircuit protection
- With output disable function

ORDERING INFORMATION

Device	Package	Operating Temperature
KA278R12	TO-220F-4L	-20°C ~ +80°C

BLOCK DIAGRAM

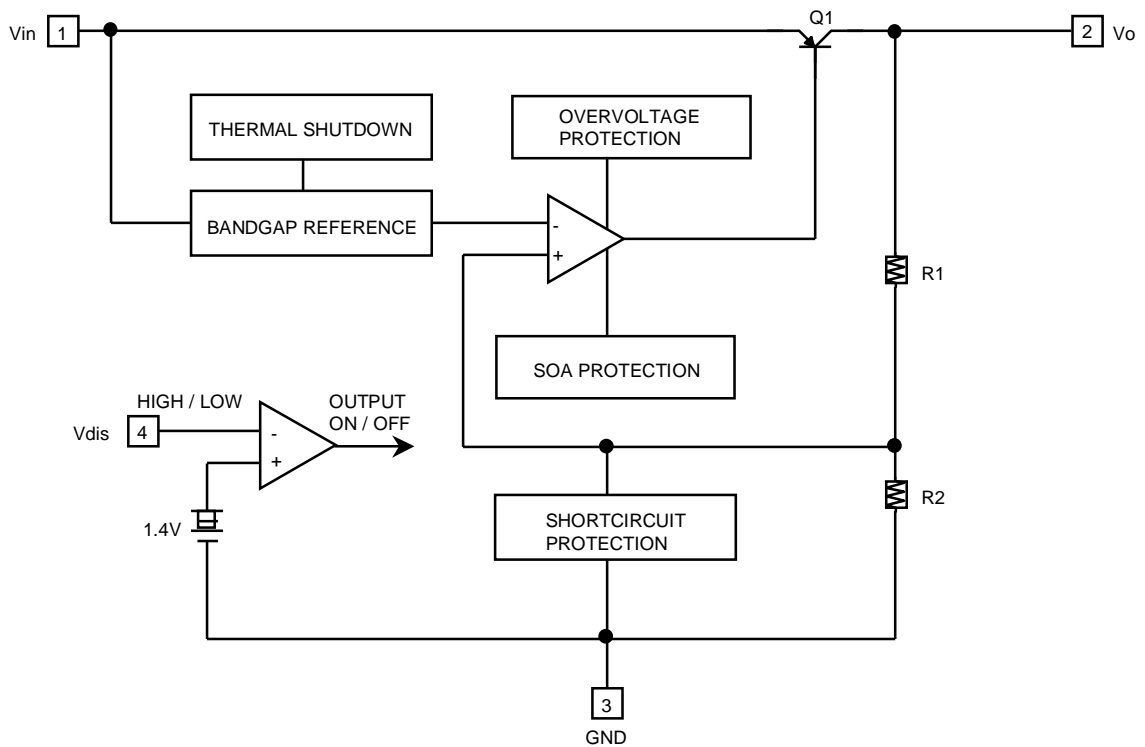

ABSOLUTE MAXIMUM RATINGS

Characteristic	Symbol	Value	Unit	Remark
Input Voltage	Vin	35	V	-
Disable Voltage	Vdis	35	V	-
Output Current	Io	2.0	A	-
Power Dissipation 1	Pd1	1.5	W	No Heatsink
Power Dissipation 2	Pd2	15	W	With Heatsink
Junction Temperature	Tj	150	°C	-
Operating Temperature	Topr	-20 ~ 80	°C	-

ELECTRICAL CHARACTERISTICS

(Vin=15V, Io=1.0A, Ta=25°C, unless otherwise specified)

Characteristic	Symbol	Test Condition	Min	Typ	Max	Unit
Output Voltage	Vo	-	11.7	12	12.3	V
Load Regulation	Rload	5mA < Io < 2A	-	0.1	2.0	%
Line Regulation	Rline	13V < Vin < 29V	-	0.5	2.5	%
Ripple Rejection Ratio	RR	note1	45	55	-	dB
Dropout Voltage	Vdrop	Io = 2A	-	-	0.5	V
Disable Voltage High	VdisH	Output Active	2.0	-	-	V
Disable Voltage Low	VdisL	Output Disabled	-	-	0.8	V
Disable Bias Current High	IdisH	Vdis = 2.7V	-	-	20	μA
Disable Bias Current Low	IdisL	Vdis = 0.4V	-	-	-0.4	mA
Quiescent Current	Iq	Io = 0A	-	-	10	mA

*note1 : These parameters, although guaranteed, are not 100% tested in production.

FIG.1 Output Voltage vs. Input Voltage

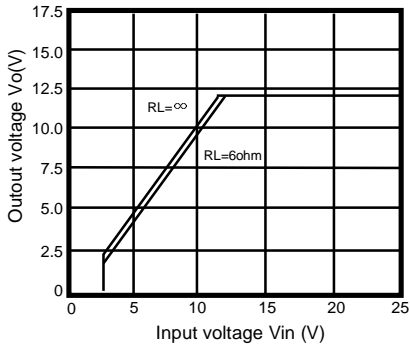

FIG.2 Quiescent Current vs. Input Voltage

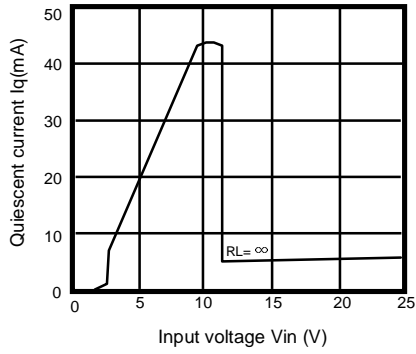

FIG.3 Output Voltage vs. Disable Voltage

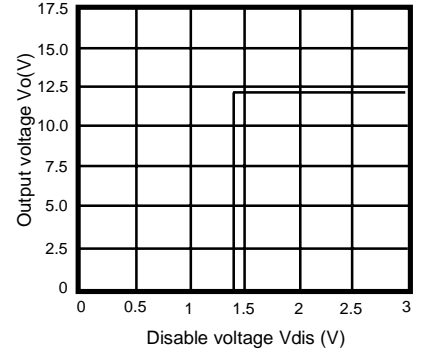

FIG.4 Output Voltage vs. Temperature(Tj)

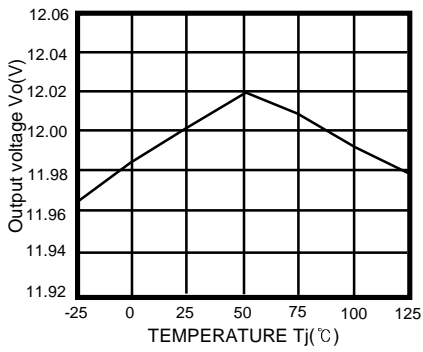

FIG.5 Quiescent Current vs. Temperature(Tj)

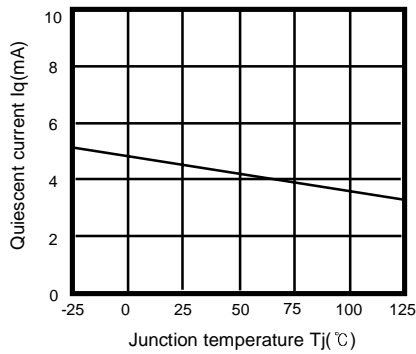

FIG.6 Dropout Voltage vs. Junction Temperature

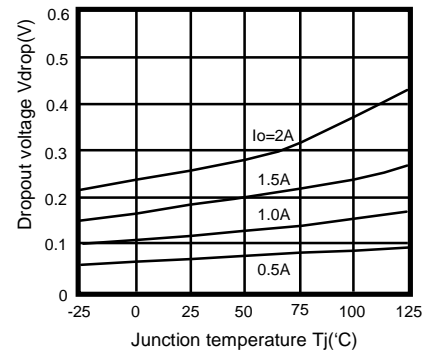
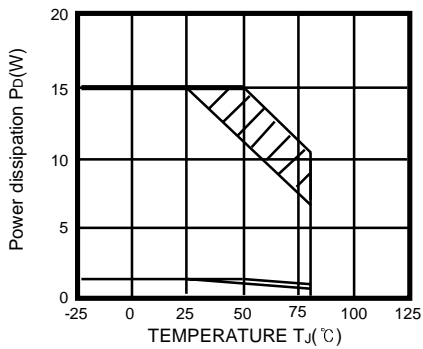
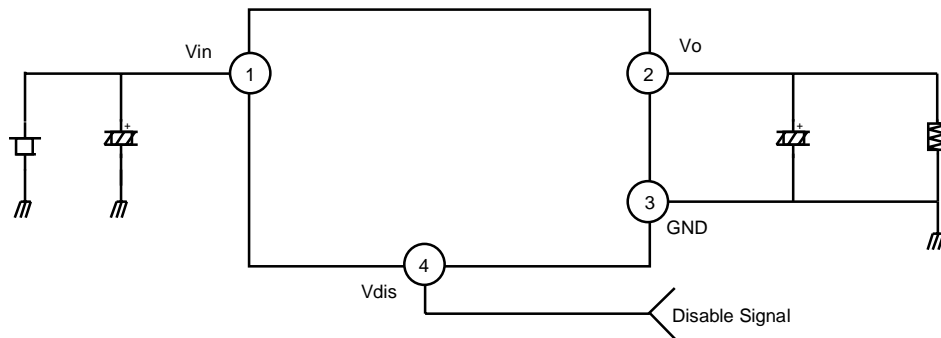

FIG.7 Power Dissipation vs. Temperature(Ta)



TYPICAL APPLICATION

FIG.1 APPLICATION CIRCUIT



- * C_i is required if regulator is located an appreciable distance from power supply filter.
- * C_o improves stability and transient response. ($C_o > 47\mu\text{F}$)

< TO220F-4L >

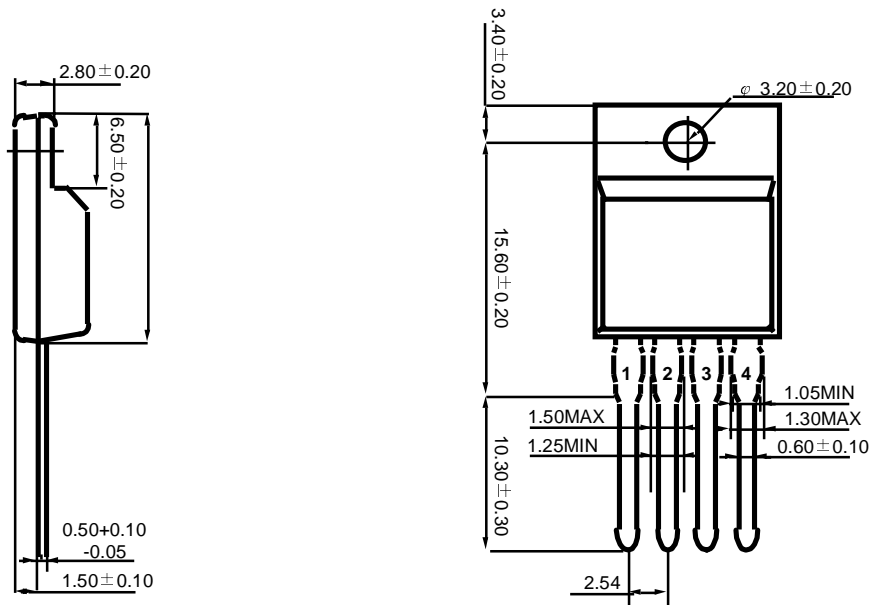

* DIMENSIONS IN MILIMETER

TRADEMARKS

The following are registered and unregistered trademarks Fairchild Semiconductor owns or is authorized to use and is not intended to be an exhaustive list of all such trademarks.

ACEx™	ISOPLANAR™	UHC™
CoolFET™	MICROWIRE™	VCX™
CROSSVOLT™	POP™	
E ² CMOS™	PowerTrench™	
FACT™	QST™	
FACT Quiet Series™	Quiet Series™	
FAST®	SuperSOT™-3	
FASTr™	SuperSOT™-6	
GTO™	SuperSOT™-8	
HiSeC™	TinyLogic™	

DISCLAIMER

FAIRCHILD SEMICONDUCTOR RESERVES THE RIGHT TO MAKE CHANGES WITHOUT FURTHER NOTICE TO ANY PRODUCTS HEREIN TO IMPROVE RELIABILITY, FUNCTION OR DESIGN. FAIRCHILD DOES NOT ASSUME ANY LIABILITY ARISING OUT OF THE APPLICATION OR USE OF ANY PRODUCT OR CIRCUIT DESCRIBED HEREIN; NEITHER DOES IT CONVEY ANY LICENSE UNDER ITS PATENT RIGHTS, NOR THE RIGHTS OF OTHERS.

LIFE SUPPORT POLICY

FAIRCHILD'S PRODUCTS ARE NOT AUTHORIZED FOR USE AS CRITICAL COMPONENTS IN LIFE SUPPORT DEVICES OR SYSTEMS WITHOUT THE EXPRESS WRITTEN APPROVAL OF FAIRCHILD SEMICONDUCTOR CORPORATION. As used herein:

1. Life support devices or systems are devices or systems which, (a) are intended for surgical implant into the body, or (b) support or sustain life, or (c) whose failure to perform when properly used in accordance with instructions for use provided in the labeling, can be reasonably expected to result in significant injury to the user.
2. A critical component is any component of a life support device or system whose failure to perform can be reasonably expected to cause the failure of the life support device or system, or to affect its safety or effectiveness.

PRODUCT STATUS DEFINITIONS

Definition of Terms

Datasheet Identification	Product Status	Definition
Advance Information	Formative or In Design	This datasheet contains the design specifications for product development. Specifications may change in any manner without notice.
Preliminary	First Production	This datasheet contains preliminary data, and supplementary data will be published at a later date. Fairchild Semiconductor reserves the right to make changes at any time without notice in order to improve design.
No Identification Needed	Full Production	This datasheet contains final specifications. Fairchild Semiconductor reserves the right to make changes at any time without notice in order to improve design.
Obsolete	Not In Production	This datasheet contains specifications on a product that has been discontinued by Fairchild semiconductor. The datasheet is printed for reference information only.