

STEPPING MOTOR DRIVER

The KA2820D2 is a monolithic integrated circuit, and suitable as a the two-phase stepping motor driver of a 5.25" FDD system.

FEATURES

- Built-in power save function
- Low saturation voltage
- Low power dissipation
- Input level: TTL, LSTTL, 5V CMOS compatible
- Standard MPU direct interface
- Built-in TSD circuit



ORDERING INFORMATION

Device	Package	Operating Temperature
KA2820D2	20-SOP-375	-20 ~ +75°C

BLOCK DIAGRAM

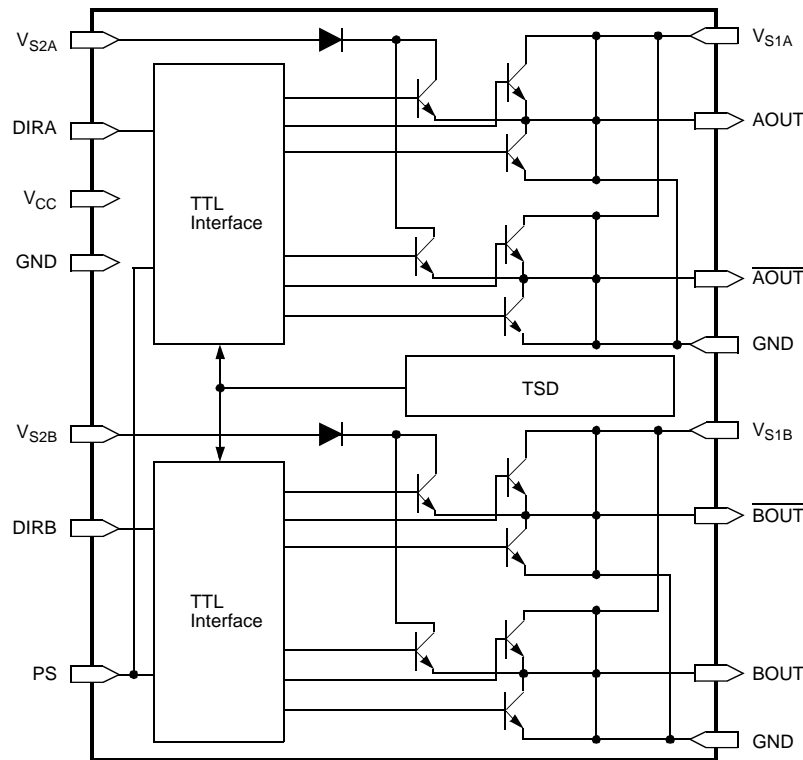

PIN CONFIGURATION

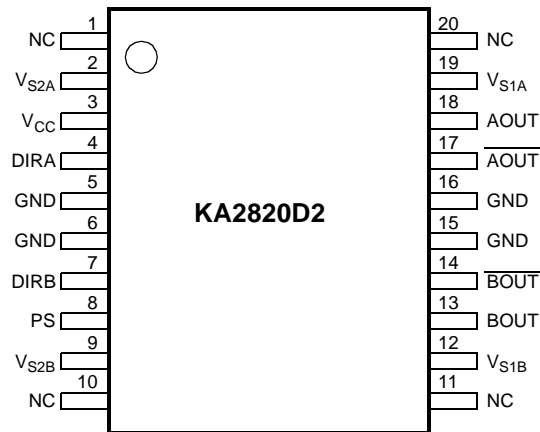

PIN DESCRIPTION

Pin No.	Symbol	Description	channel
1	NC	No connection	–
2	V_{S2A}	A-channel holding supply voltage	A
3	V_{CC}	Logic part supply voltage	A, B
4	DIRA	A-channel direction input	A
5	GND	Signal ground	A, B
6	GND	Signal ground	A, B
7	DIRB	B-channel direction input	B
8	PS	Power save input	A, B
9	V_{S2B}	B-channel holding supply voltage	B
10	NC	No connection	–
11	NC	No connection	–
12	V_{S1B}	B-channel seeking supply voltage	B
13	\overline{BOUT}	B-channel output	B
14	BOUT	B-channel inverting output	B
15	GND	Power ground	A, B
16	GND	Power ground	A, B
17	\overline{AOUT}	A-channel inverting output	A
18	AOUT	A-channel output	A
19	V_{S1A}	A-channel seeking supply voltage	A
20	NC	No connection	–

ABSOLUTE MAXIMUM RATING (Ta=25°C)

Characteristics	Symbol	Value	Unit
Logic part supply voltage	V_{CC}	7.0	V
Seeking supply voltage	V_{S1}	15.0	V
Holding supply voltage	V_{S2}	7.0	V
Input voltage	V_{IN}	V_{CC}	V
Seeking output current (Continuouts)	I_{OS}	330	mA
Seeking output current (Peak)	I_{OSPEAK}	500	mA
Holding output current	I_{OH}	200	mA
Package power dissipation	P_D	1.0	W
Operating temperature range	T_{OPR}	-20 ~ 75	°C
Storage temperature	T_{STG}	-40 ~ 125	°C

RECOMMENDED OPERATING CONDITIONS

Characteristics	Symbol	Min.	Typ.	Max.	Unit
Logic part supply voltage	V_{CC}	4.5	5.0	5.5	V
Seeking supply voltage	V_{S1}	10.2	12.0	13.8	V
Holding supply voltage	V_{S2}	4.5	5.0	5.5	V

ELECTRICAL CHARACTERISTICS

(Ta=25°C, V_{CC}=5V, V_{S1}=12V, V_{S2}=5V, unless specified otherwise)

Characteristic	Symbol	Test conditions	Min.	Typ.	Max.	Unit
Digital input "L" voltage	V _{IL}	–	–	–	0.8	V
Digital input "H" voltage	V _{IH}	–	2.0	–	–	V
Digital input "L" current	I _{IL}	V _{IN} =0.8V	–	0	10	μA
Digital input "H" current	I _{IH1}	V _{IN} =2.0V	–	1	10	μA
	I _{IH2}	V _{IN} =5V	–	0.3	1.0	mA
	I _{VCC}	PS=0.8V	–	25	33	mA
	I _{V_{S1}L}	PS=0.8V	–	6	10	mA
Supply current	I _{V_{S2}L}	PS=0.8V	–	–	0.1	mA
	I _{V_{CC}H}	PS=2.0V	–	25	33	mA
	I _{V_{S1}H}	PS=2.0V	–	1	2	mA
	I _{V_{S2}H}	PS=2.0V	–	2.5	4	mA
Output sustain voltage	V _{SUS}	I _O =130mA, PS=0.8V	18	–	–	V
VS1 output saturation voltage	V _{SAT1}	I _O =130mA, PS=2.0V	–	1.5	2.0	V
VS2 output saturation voltage	V _{SAT2}	I _O =130mA	–	1.5	2.0	V
Output clamp voltage	V _{FU}	I _O =330mA (Upper)	–	3.0	5.0	V
	V _{FL}	I _O =330mA (Lower)	–	1.5	2.0	V
Output delay time	T _{PLH}	Input pulse (2kHz)	–	1.0	5.0	μs
	T _{PHL}	Input pulse (2kHz)	–	1.0	5.0	μs
TSD operating temperature	TSD	–	125	150	–	°C
TSD hysteresis	ΔTSD	–	–	25	–	°C

APPLICATION INFORMATION

1. MOTOR CONTROL LOGIC

Mode selection-truth table

Input		Output			Operating Mode
PS	DIRX	XOUT	\overline{XOUT}		
L	L	L	H+	Seeking Mode	H+: Operating by V_{S1} ($V_{S1}=12V$)
L	H	H+	L		
H	L	L	H-	Open Mode	H-: Operating by V_{S2} ($V_{S2}=5V$)
H	H	H-	L		

NOTE:

DIRX: DIRA or DIRB (Direction input)

XOUT: AOUT or BOUT (Non-inverting output)

\overline{XOUT} : \overline{AOUT} or \overline{BOUT} (Inverting output)

X: Indicate each channel (A and B)

2. HOLDING AND SEEKING MODE

In rotating high speed (Seeking Mode), stepping motor is operated by high voltage (V_{S1} : Seeking power supply voltage "12").

In holding mode, stepping motor is operated by low voltage (V_{S2} : Holding power supply voltage "5").

When the PS input signal is high, it will be minimized power consumption in this device.

3. MAXIMUM DRIVE CURRENT CAPACITY AS FOLLOWS

- Peak seeking output current: 0.5A
- Continued seeking output current: 0.33A
- Holding output current: 0.2A

TIMING CHART

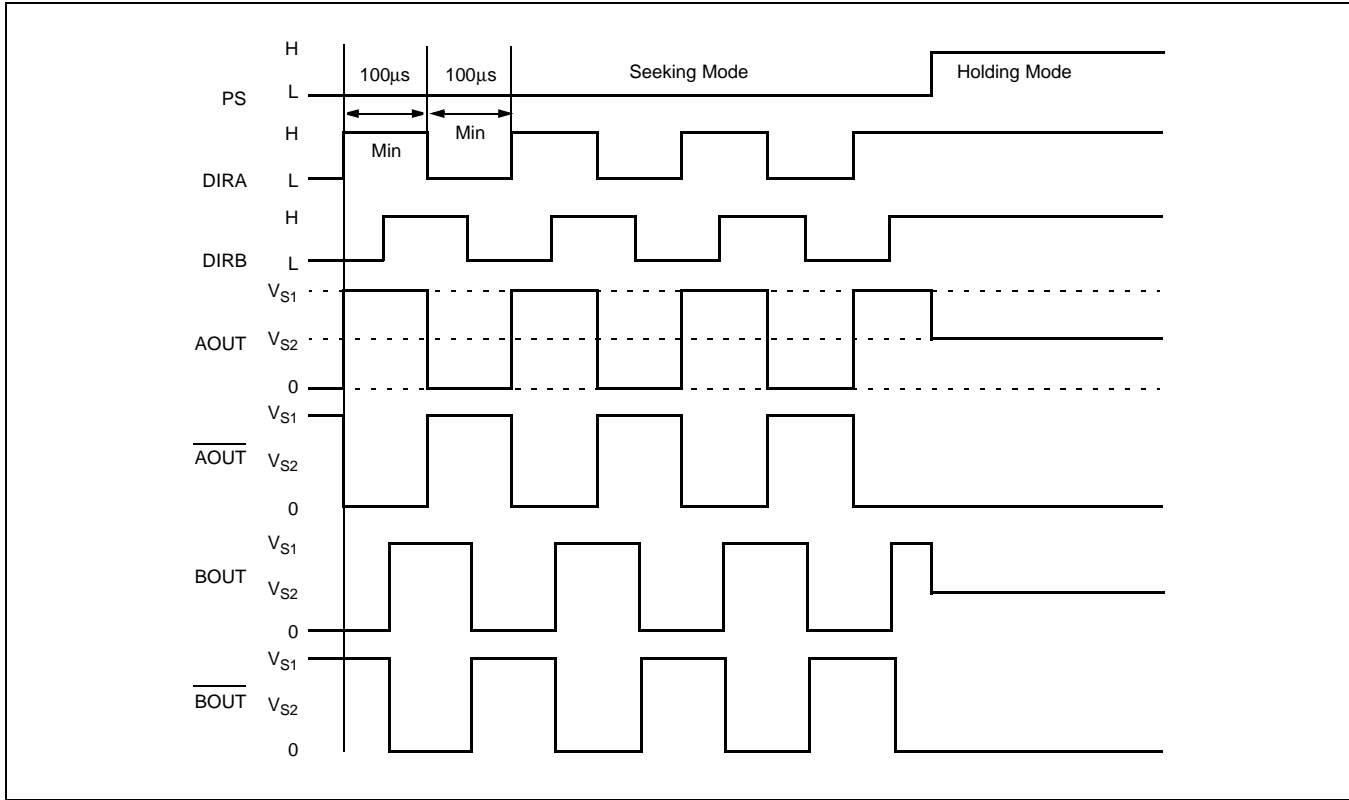

APPLICATION CIRCUIT

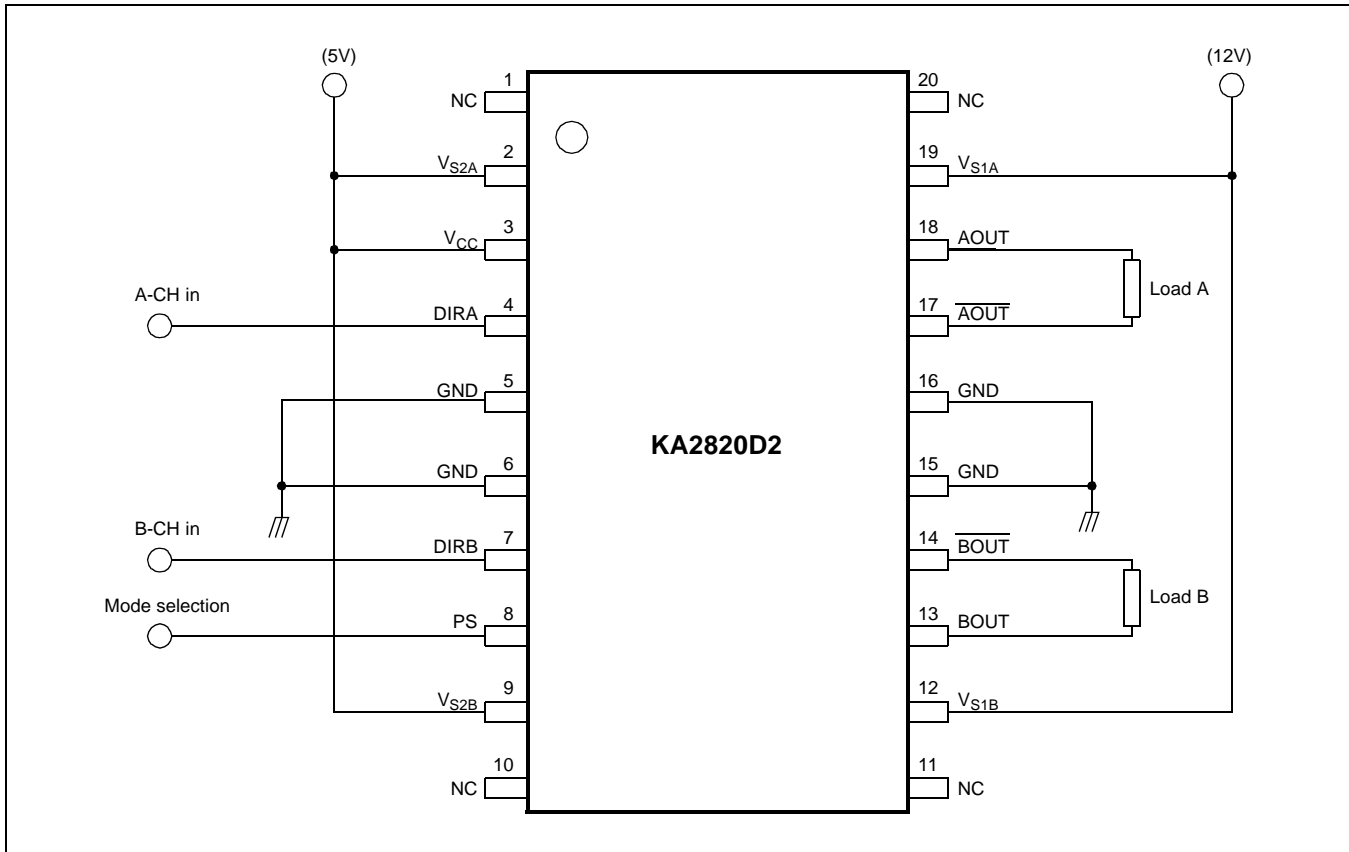

PACKAGE DIMENSION

20-SOP-375

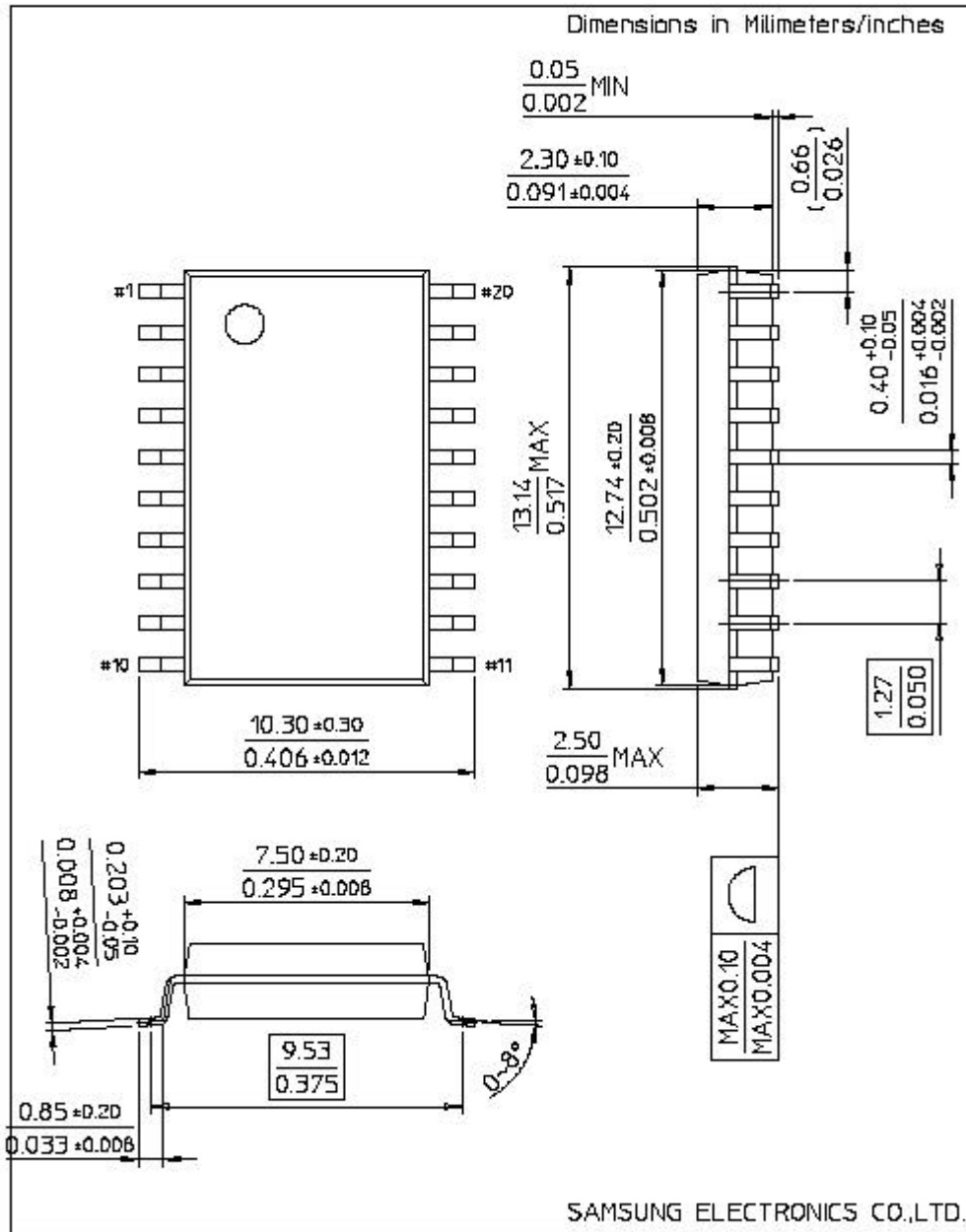

TRADEMARKS

The following are registered and unregistered trademarks Fairchild Semiconductor owns or is authorized to use and is not intended to be an exhaustive list of all such trademarks.

ACEx™	ISOPLANAR™
CoolFET™	MICROWIRE™
CROSSVOLT™	POP™
E ² CMOS™	PowerTrench™
FACT™	QS™
FACT Quiet Series™	Quiet Series™
FAST®	SuperSOT™-3
FASTr™	SuperSOT™-6
GTO™	SuperSOT™-8
HiSeC™	TinyLogic™

DISCLAIMER

FAIRCHILD SEMICONDUCTOR RESERVES THE RIGHT TO MAKE CHANGES WITHOUT FURTHER NOTICE TO ANY PRODUCTS HEREIN TO IMPROVE RELIABILITY, FUNCTION OR DESIGN. FAIRCHILD DOES NOT ASSUME ANY LIABILITY ARISING OUT OF THE APPLICATION OR USE OF ANY PRODUCT OR CIRCUIT DESCRIBED HEREIN; NEITHER DOES IT CONVEY ANY LICENSE UNDER ITS PATENT RIGHTS, NOR THE RIGHTS OF OTHERS.

LIFE SUPPORT POLICY

FAIRCHILD'S PRODUCTS ARE NOT AUTHORIZED FOR USE AS CRITICAL COMPONENTS IN LIFE SUPPORT DEVICES OR SYSTEMS WITHOUT THE EXPRESS WRITTEN APPROVAL OF FAIRCHILD SEMICONDUCTOR CORPORATION. As used herein:

1. Life support devices or systems are devices or systems which, (a) are intended for surgical implant into the body, or (b) support or sustain life, or (c) whose failure to perform when properly used in accordance with instructions for use provided in the labeling, can be reasonably expected to result in significant injury to the user.
2. A critical component is any component of a life support device or system whose failure to perform can be reasonably expected to cause the failure of the life support device or system, or to affect its safety or effectiveness.

PRODUCT STATUS DEFINITIONS

Definition of Terms

Datasheet Identification	Product Status	Definition
Advance Information	Formative or In Design	This datasheet contains the design specifications for product development. Specifications may change in any manner without notice.
Preliminary	First Production	This datasheet contains preliminary data, and supplementary data will be published at a later date. Fairchild Semiconductor reserves the right to make changes at any time without notice in order to improve design.
No Identification Needed	Full Production	This datasheet contains final specifications. Fairchild Semiconductor reserves the right to make changes at any time without notice in order to improve design.
Obsolete	Not In Production	This datasheet contains specifications on a product that has been discontinued by Fairchild semiconductor. The datasheet is printed for reference information only.